

## ISSUANCE OF SPECIAL PERMITS FOR TRACTORS WITH A WHEELBASE GREATER THAN 6.2 METRES

The Regulation respecting vehicle loads and dimensions imposes a 6.2 metre limit on the wheelbase of a tractor in a vehicle combination more than 19 metres long. Tractors assembled before January 1, 1999 are only required to conform to this requirement effective from January 1, 2010. This tractor wheelbase limit is applicable in most Canadian jurisdictions but not in the United States.

The wheelbase of a tractor is longitudinal distance measured between the axis of rotation of the front axle and the midpoint of the vehicle's rear axle group. The wheelbase of a semi-trailer is measured between the kingpin and the centre of the single axle, the tandem axle or triple axle of the semi-trailer (Figure 1). The limit on wheelbases is intended to reduce low-speed offtracking by a vehicle combination. In a tight turn, a tractor with a larger wheelbase will take up more room executing the turn. It will have to intrude more into the oncoming lane or take up more space on its own side of the road. This increases the risks of accidents with other road users, pedestrians and cyclists.

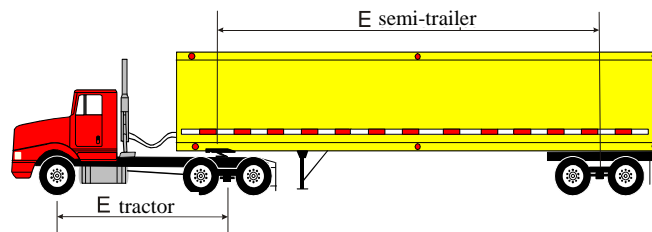

FIGURE 1: Wheelbase of a tractor and a semi-trailer

The offtracking of a vehicle or a vehicle combination is measured by the maximum distance between the trajectories of the first and last axles during a specific turn (Figure 2). For a tractor-semi-trailer, the acceptable offtracking, according to the performance criteria established in Canada, which often serve as an international reference, is 5.5 metres. This offtracking is obtained by a tractor with a wheelbase of 6.2 metres and a semi-trailer with a wheelbase of 12.5 metres.

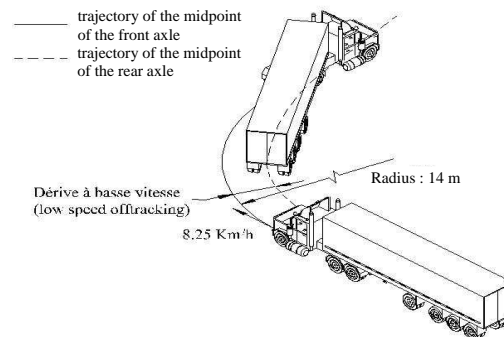

FIGURE 2: Offtracking of a tractor-semi-trailer

It is possible to increase the tractor's wheelbase beyond 6.2 metres while maintaining the offtracking of a tractor-semi-trailer vehicle combination at 5.6 metres. However, the semi-trailer wheelbase should be less than 12.5 metres. The Department has developed a simplified formula that allows a tractor's maximum wheelbase to be determined according to the semi-trailer wheelbase while conforming to the performance criteria established for offtracking of a vehicle or a vehicle combination. This formula, which is valid for a tractor with a wheelbase greater than 6.2 metres but not more than 7.2 metres, is as follows:

$$W_{\text{tractor}} \leq (25 - 1.5W_{\text{semi-trailer}})$$

Vehicle combinations composed of a tractor and a semi-trailer longer than 19 metres, for which the tractor, assembled after December 31, 1998, has a wheelbase greater than 6.2 metres, can be authorized to operate in Québec. However, a special permit is required, and certain conditions apply. A specimen of the special operating permit is presented in Schedule 1. This permit does not authorize the operation of a semi-trailer with a wheelbase greater than 12.5 metres. The total length of the vehicle combination is maintained at 23 metres. The table opposite presents different situations that can apply depending on the length of the tractor and semi-trailer wheelbases.

<b>W<sub>tractor</sub></b>	<b>W<sub>semi-trailer</sub></b>	<b>Operation</b>
-----	> 12.50 m	Not authorized
< 6.2 m	≤ 12.50 m	Authorized without permit
6.3 m	≤ 12.47 m	Permit required
6.4 m	≤ 12.40 m	Permit required
6.5 m	≤ 12.33 m	Permit required
6.6 m	≤ 12.27 m	Permit required
6.7 m	≤ 12.20 m	Permit required
6.8 m	≤ 12.13 m	Permit required
6.9 m	≤ 12.07 m	Permit required
7.0 m	≤ 12.00 m	Permit required
7.1 m	≤ 11.93 m	Permit required
7.2 m	≤ 11.87 m	Permit required
> 7.2 m	-----	Not authorized

The special permit authorizing operation of a tractor with a wheelbase greater than 6.2 metres can be obtained for an annual cost of \$150 (plus \$10 administration fee) by providing the following information to the Ministère des Transports:

- the name and address of the enterprise appearing on the tractor's registration certificate;
- the register identification number (RIN) of the Commission des transports du Québec;
- the name, telephone number, fax number and email address of a resource person;
- the registration number and tractor assembly date.

Permit applications can be filed via the Internet or by mail.

On the Internet, it is sufficient to access the Ministère des Transports du Québec at <http://www.mtq.gouv.qc.ca/fr/camionnage/permis/article633.asp> and follow the instructions appearing on the screen. Payment may be made online by credit card.

By mail, it is necessary to send us the attached form once it is completed (Schedule 2) and a cheque payable to **Minister of Finance of Québec** at the following address:

Centre de gestion 1630 (management centre)  
Ministère des Transports du Québec  
700, boulevard René-Lévesque Est  
Québec (Québec) G1R 5H1

The issuance of these special permits is meant to ensure better compatibility of the Québec standards with those of jurisdictions that authorize tractors with a wheelbase greater than 6.2 metres. It is important to mention that the operation of tractors with a wheelbase over 6.2 metres is not authorized in all Canadian jurisdictions. It is necessary to verify the applicable rules in the other jurisdictions before operating a vehicle there.

For information concerning special permits or any information regarding vehicle loads and dimensions, you can visit the Department's Web site at [www.mtq.gouv.qc.ca](http://www.mtq.gouv.qc.ca) or contact Info-camionnage by phone at the number appearing at the bottom of the first page of this document or by email to [communications@mtq.gouv.qc.ca](mailto:communications@mtq.gouv.qc.ca).

Direction du transport routier des marchandises  
(Road Freight Transportation Directorate)



Valide du \_\_\_\_\_ au \_\_\_\_\_

IDENTIFICATION DU TITULAIRE :

**Spécimen**

IDENTIFICATION DU TRACTEUR (numéro d'immatriculation) :

OBJET DU PERMIS :

Ce permis autorise la circulation d'un ensemble de véhicules, composé d'un tracteur et d'une semi-remorque, dont la longueur excède **19 mètres** et dont le tracteur est **assemblé après le 31 décembre 1998** avec un **empattement de plus de 6,2 mètres**.

CONDITIONS

- ◆ La longueur de l'ensemble de véhicules, chargement compris, doit être inférieure ou égale à **23 mètres**.
- ◆ Le tracteur doit avoir **trois essieux** et un entraxe d'au moins **3 mètres**.
- ◆ La distance entre la partie extrême arrière de la semi-remorque, chargement compris, et le centre de son essieu simple, de son essieu tandem ou de son essieu triple doit être **d'au plus 35 % de l'empattement de la semi-remorque** soit la distance entre le centre de cet essieu et le centre du pivot d'attelage.
- ◆ L'empattement en mètre du tracteur doit être inférieur ou égal à la valeur calculée à partir de l'équation suivante sans excéder **7,2 mètres** :

$$\text{Empattement}_{\text{tracteur}} \leq (25 - 1,5 \text{ Empattement}_{\text{semi-remorque}})$$

L'empattement du tracteur est la distance entre l'axe de rotation de l'essieu avant et le centre du groupe d'essieux arrière.

L'empattement de la semi-remorque est la distance entre le centre du pivot d'attelage et le centre de l'essieu simple, tandem ou triple.

- ◆ Ce permis doit être signé par le titulaire ou son représentant.
- ◆ Le conducteur doit avoir en sa possession l'original ou une copie lisible de ce permis spécial.

RENSEIGNEMENTS SUPPLÉMENTAIRES

- ◆ L'empattement de la semi-remorque ne doit pas dépasser 12,5 mètres.
- ◆ Ce permis spécial n'est pas requis lorsque le **tracteur circule seul**.
- ◆ Ce permis ne peut être transféré. À la date d'échéance, le Ministre se réserve le droit de ne pas le renouveler.
- ◆ Ce permis n'enlève pas l'obligation de se conformer à toute autre exigence législative et réglementaire.
- ◆ Quant aux autres normes, le véhicule doit être conforme au Règlement sur les normes de charges et de dimensions applicables aux véhicules routiers et aux ensembles de véhicules routiers.
- ◆ Le nom et l'adresse du titulaire inscrits sur le présent permis spécial doivent correspondre aux données du certificat d'immatriculation du tracteur.

**APPLICATION FOR SPECIAL PERMITS  
FOR TRACTORS WITH A WHEELBASE GREATER THAN 6.2 METRES**

Issued by the Minister of Transport under section 633 of the Québec Highway Safety Code

<b>Name of enterprise:</b>	
<b>Address:</b>	
<b>Municipality:</b>	<b>Email:</b>
<b>Province:</b>	<b>Postal code:</b>
<b>Telephone:</b>	<b>Fax:</b>
<b>RIN*:</b>	<b>Resource person:</b>

$$\text{Wheelbase}_{\text{tractor}} \leq (25 - 1.5 \text{ Wheelbase}_{\text{semi-trailer}})$$

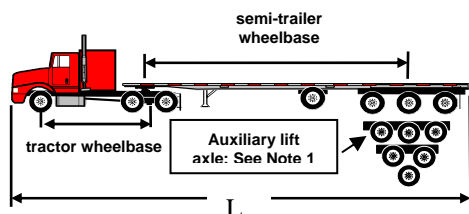

**L :** total vehicle length

**Tractor wheelbase:** distance between the axis of rotation of the front axle and the midpoint of the rear axle group.

**Semi-trailer wheelbase:** distance between the midpoint of the kingpin and the midpoint of the single, tandem or triple axle.

**Note:**

- 1) The auxiliary lift axles shall not be considered in the establishment of the **wheelbase**. For example, when the semi-trailer is equipped with 3 axles, one of which is a retractable single axle and the other 2 of which form a tandem, the **wheelbase** shall be measured from the midpoint of the tandem axle.
- 2) The vehicle combination does not need a permit to operate when the length « L » is less than or equal to **19 meters** or when the tractor's year of assembly is prior to January 1, 1999.
- 3) The tractor wheelbase shall be less than or equal to the value calculated from the following equation, without exceeding 7.2 metres.
- 4) The semi-trailer wheelbase shall be less than or equal to 12.5 metres.
- 5) The tractor should have **3 axles** and an interaxle equal or higher than **3 meters**.

<b>TRACTOR</b>		
You can apply for 6 special permits on this form.		
<b>Registration</b>	<b>Assembly (year - month)</b>	<b>Wheelbase meters</b>

**I certify that the information recorded on this form is accurate.**

**Signature:** \_\_\_\_\_ **Date:** \_\_\_\_\_

\* This number corresponds to the **register identification number**, which was assigned to you upon your compulsory registration at the Commission des transports du Québec. The CTQ makes a Web site available to help you locate it at [www.ctq.gouv.qc.ca/cote/rech.asp](http://www.ctq.gouv.qc.ca/cote/rech.asp) or call the following number: 1 888 355-0511.