

SINGLE ANIMAL SCALE & SCALE CAGE

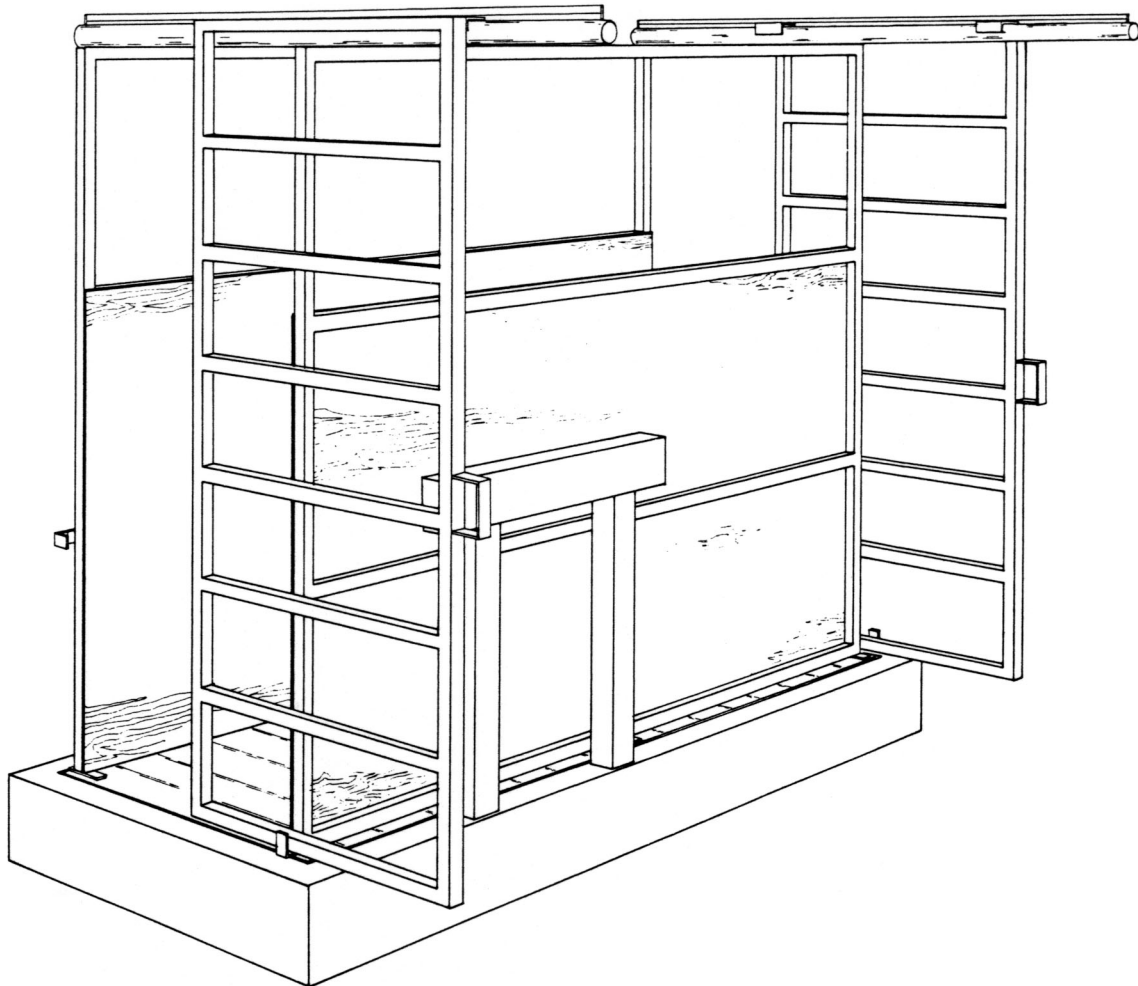

This leaflet plan contains details for constructing a scale cage and provides some information on scales. The cage is constructed of 1 1/2 in. x 1 1/2 in. x .125 in. square tube with pressure treated plywood inside. Pressure treated plywood can be bolted to the exterior of the exit gate if desired.

The scale cage is mounted on the scale platform. The scale and scale cage is detached from the working

chute to prevent inaccurate readings obtained when an animal leans on the sides or gate of an attached chute.

To keep small animals from moving and turning around in the scale cage, an adjustable scale cage side can be used to narrow the cage width. An alternative is to put a spacer inside to narrow the cage width.

The gate slides on a pipe welded across the top ends of the side panels. A removable flat iron guide prevents the door from lifting off the pipe.

DEVELOPED BY SASKATCHEWAN AGRICULTURE

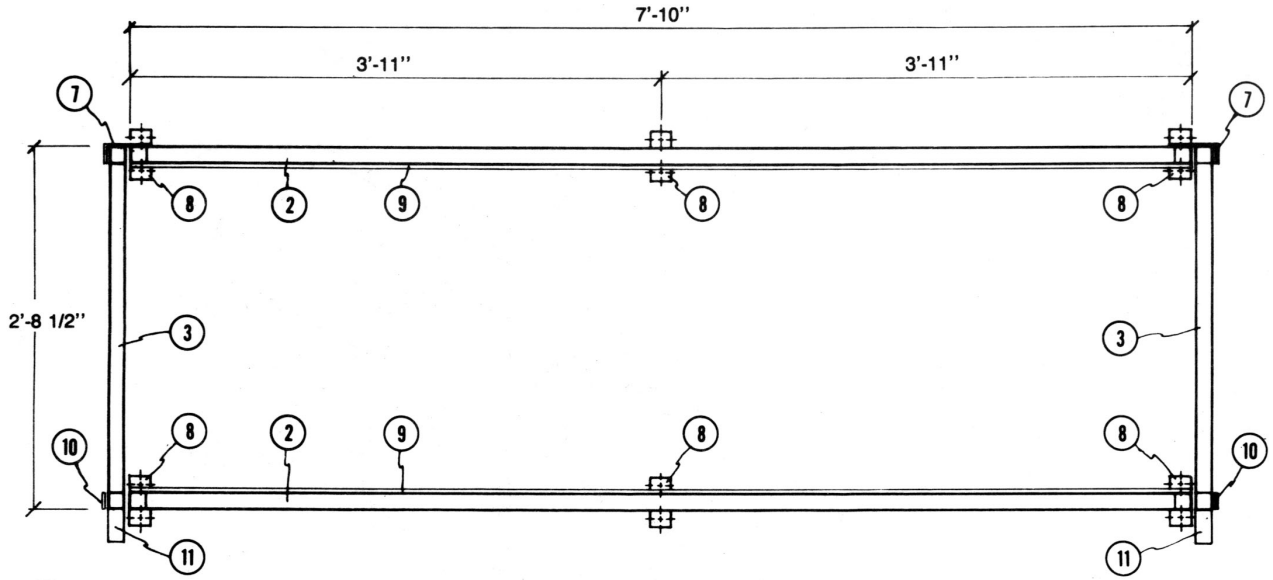

1

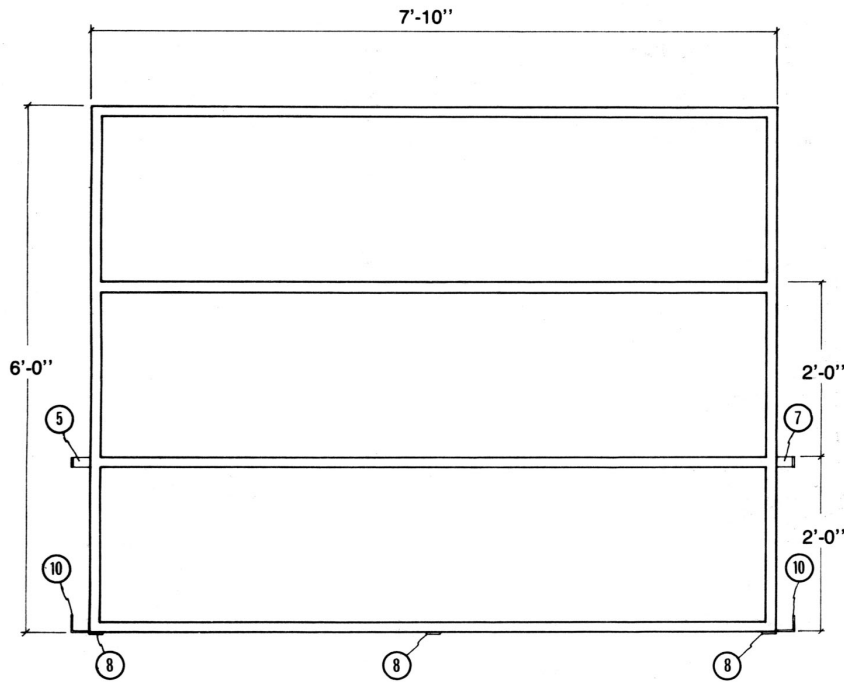

2

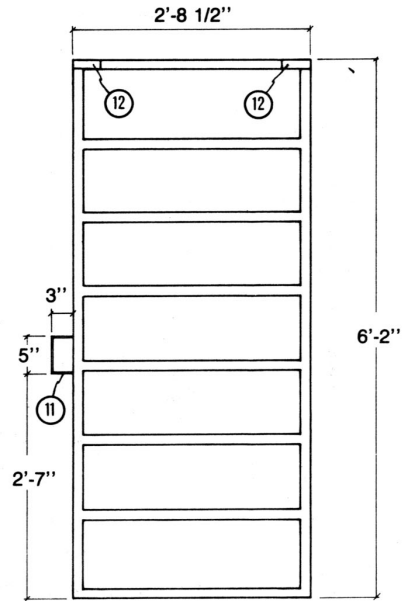

3

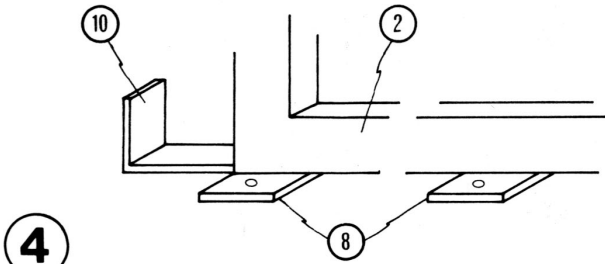

4

- 1 Scale cage plan
- 2 Cage side panel, 1 1/2" x 1 1/2" x .125" sq. tube
- 3 Sliding gates, 1 1/2" x 1 1/2" x .125" sq. tube
- 4 Anchor detail
- 5 Slider detail'
- 6 Slider section

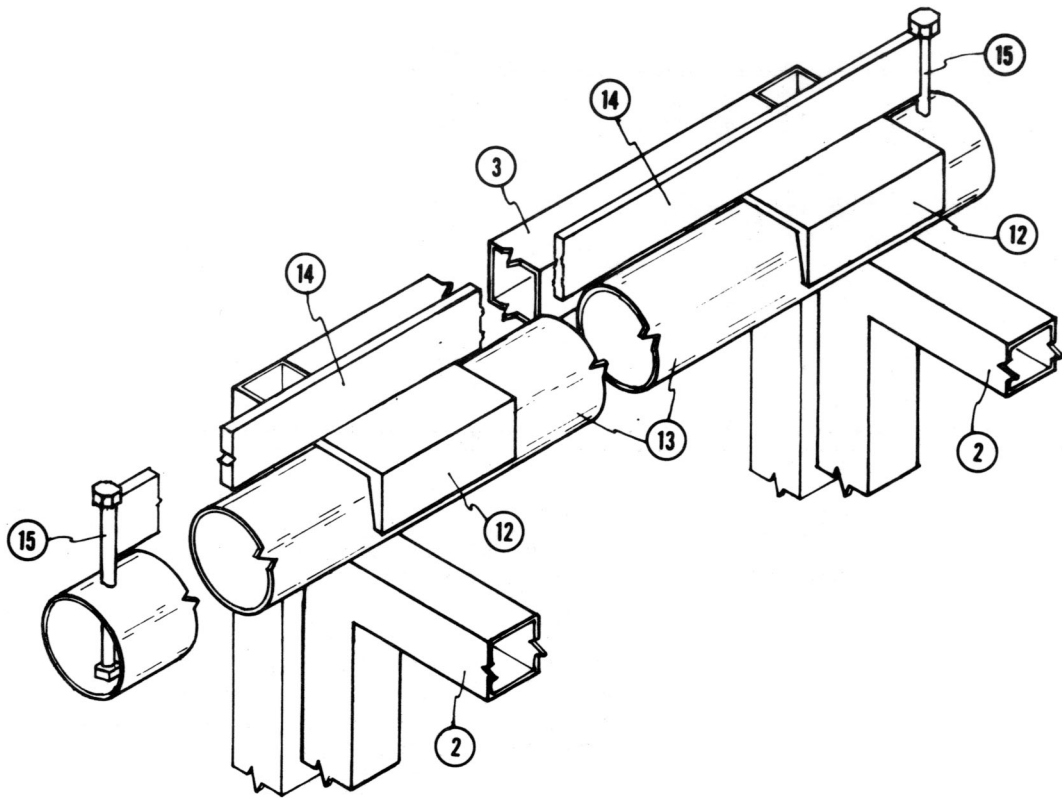

5

- 7 Gate stop, 1 1/2" x 1/4" flat iron
- 8 1 1/2" x 1/4" x 5" flat iron c/w two 3/8" \varnothing holes, weld to ②
- 9 4'-0" x 7'-10" pressure treated plywood sides, bolt to ② with 1/4" \varnothing bolts @ 2'-0" o.c.
- 10 Gate guide, 1 1/2" x 1/4" flat iron
- 11 Pull handle, 1 1/2" x 1/4" flat iron bend to suit
- 12 3" channel x 4" long, weld to ③
- 13 2 3/8" O.D. x 5'-6" slider pipe c/w two 5/16" \varnothing hole, weld to ②
- 14 Gate hold down, 1 1/2" x 1/4" x 5'-3 3/4" flat iron, weld to ⑤
- 15 1/4" \varnothing x 6" bolt c/w 2 nuts for height adjustment

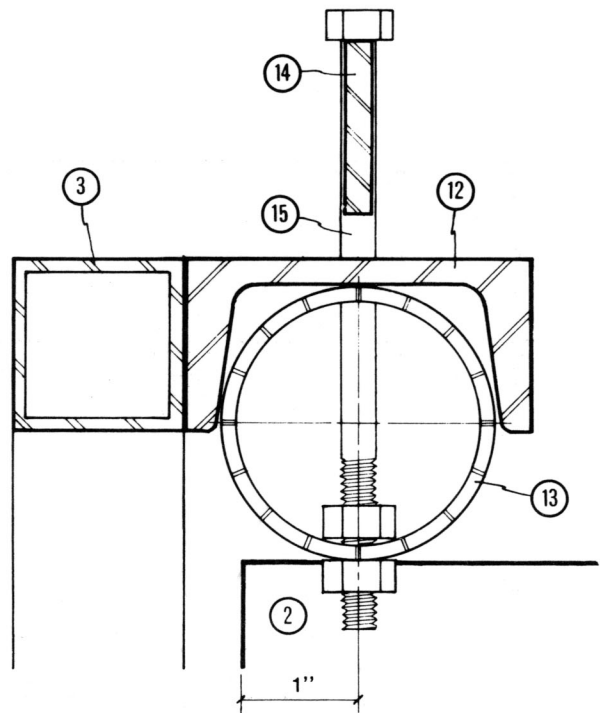

6

315-06

SCALE SELCTION

NEW: 01:85

Recording the rate of gain of animals over a period of time is very important for efficient cattle management. The animals' rate of gain is useful in culling animals and selecting feed rations.

Feed and water cattle at the same time period each day before weighing to obtain consistent results in recording accurate weights.

Select a scale with sufficient capacity to weigh the scale cage unit plus the heaviest animal to be weighted. Consider the following factors when selecting a scale:

- capital cost
- durability
- ease of removal
- suitability for winter use, if required

Beam scales are read adjacent to the scale cage unit. They weigh accurately over a long period of time. Beam scales require little maintenance and do not require storage indoors when not in use. However, the contact points should be protected from water, ice and snow. If the scale does not readily balance, make certain that the knife edge contact points are in place.

Electronic scales use load cells with remote digital readout. An advantage of the remote readout is that it can be located in a heated building adjacent to the scale. The remote digital readout portion is disconnected from the load cells and stored inside when not in use. The connections to the load cells must be protected from the weather. The scale should contain a dampening feature for fast reading.

Hydraulic scales with remote dial readout use automatic transmission fluid for all weather capability. A limitation is that the scale dial on some hydraulic scales is graduated in 10 pound increments.

Mount the scale on a firm surface, such as concrete, with yard drainage away from the scale.

An existing cattle squeeze, separate from the chute, can be adapted as the scale cage.