

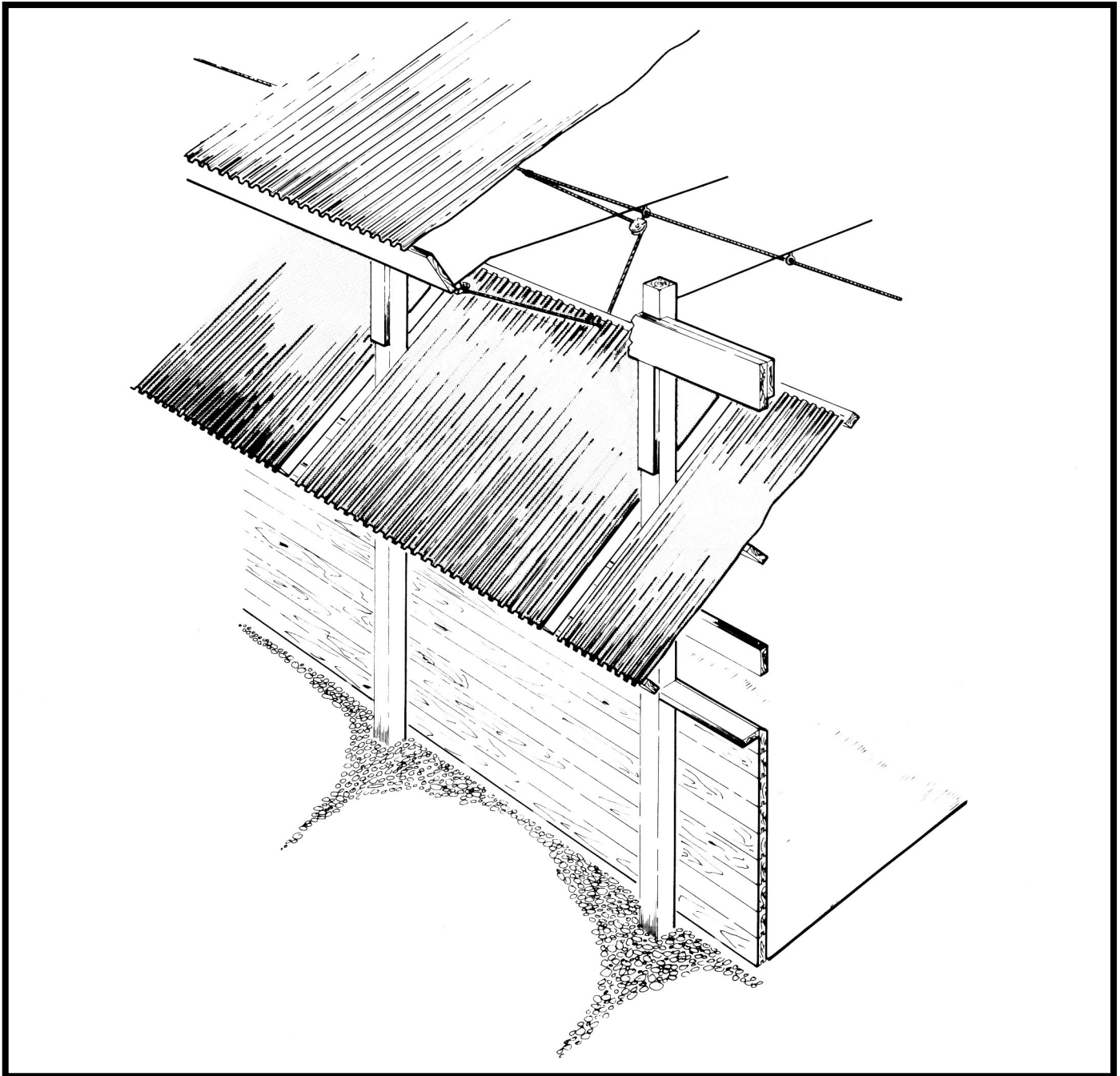

# TILT – IN – WALL PANEL VENTILATION



DEVELOPED BY CANADA PLAN SERVICE

## TILT - IN - WALL PANEL VENTILATION

CPS  
PLAN 9355 NEW: 83:09

Naturally-ventilated or 'cold' barns can be used to shelter cold-tolerant livestock such as beef cattle, dairy cattle, and sheep. Ventilation in these cases must often be adjusted quite frequently for significant temperature changes, wind, snow or rain.

This leaflet gives a method of making quick adjustments to sidewall openings. These openings are used primarily as fresh-air inlets, in combination with a fixed slot opening that serves as a center air outlet at the roof ridge.

**TILT-IN-WALL PANELS** For maximum summer ventilation, very large wall openings are best; section drawing 2 shows a panel 6 ft high and pivoted at the mid-height. This size of panel is best suited to typical pole-barn walls about 10 to 13 ft high. With these large panels, wind forces can be quite high, and the center-pivot design helps balance these forces, permitting a simple control system. For winter ventilation only, shorter wall panels (perhaps 2 ft high) may be adequate. The panels can be hinged at the bottom edge and tilted inwards at the top. The control system remains the same as for the taller, center-pivot design.

Exterior cladding on the tilt-in wall panels may be sheet metal or plywood to match the siding on the barn

endwalls. Another idea is to use translucent reinforced plastic roofing, which can provide natural lighting. In either case, fasten the cladding to the frames with the special roofing screws designed for this purpose; ordinary roofing nails may loosen after regular operation of the panels.

**WINCH-AND-CABLE CONTROL SYSTEM** In winter weather, small adjustments (from closed to slightly open) can provide enough environmental control. To secure the adjustment against the forces of wind, a two-way cable system as shown is best. Boat dealers and marine hardware stores are the best sources of strong, rust-proof pulleys and cable. For the first-stage components attached directly to each panel, nylon or polyester rope and outboard motorboat steering pulleys are strong enough. However, the control winches, main cables and their pulleys must handle the sum of all forces on a whole row of doors, so use high-tensile galvanized or stainless steel cable, with heavy-duty marine 'cheek blocks' (pulleys) wherever the cables must change direction. Be careful to mount these pulleys so that they align correctly and bisect the angle through which the cable bends.

Cable winches rated for 800 to 1200 pounds pull are quite inexpensive and are adequate for most of these applications. Mount the winches in pairs (one to open, the other to close a row of panels), both on the same post. This should be at or near the barn entrance most frequently used when checking the livestock. Choose this location carefully, as the adjustments will be more likely to be made whenever required if the operation is easy and convenient.

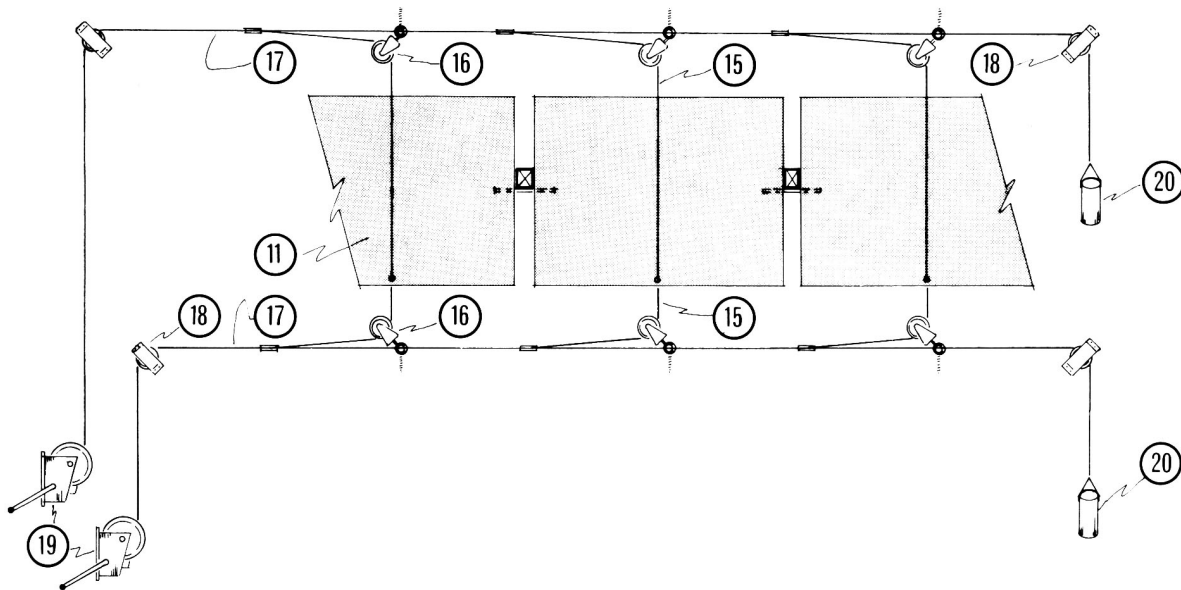

1

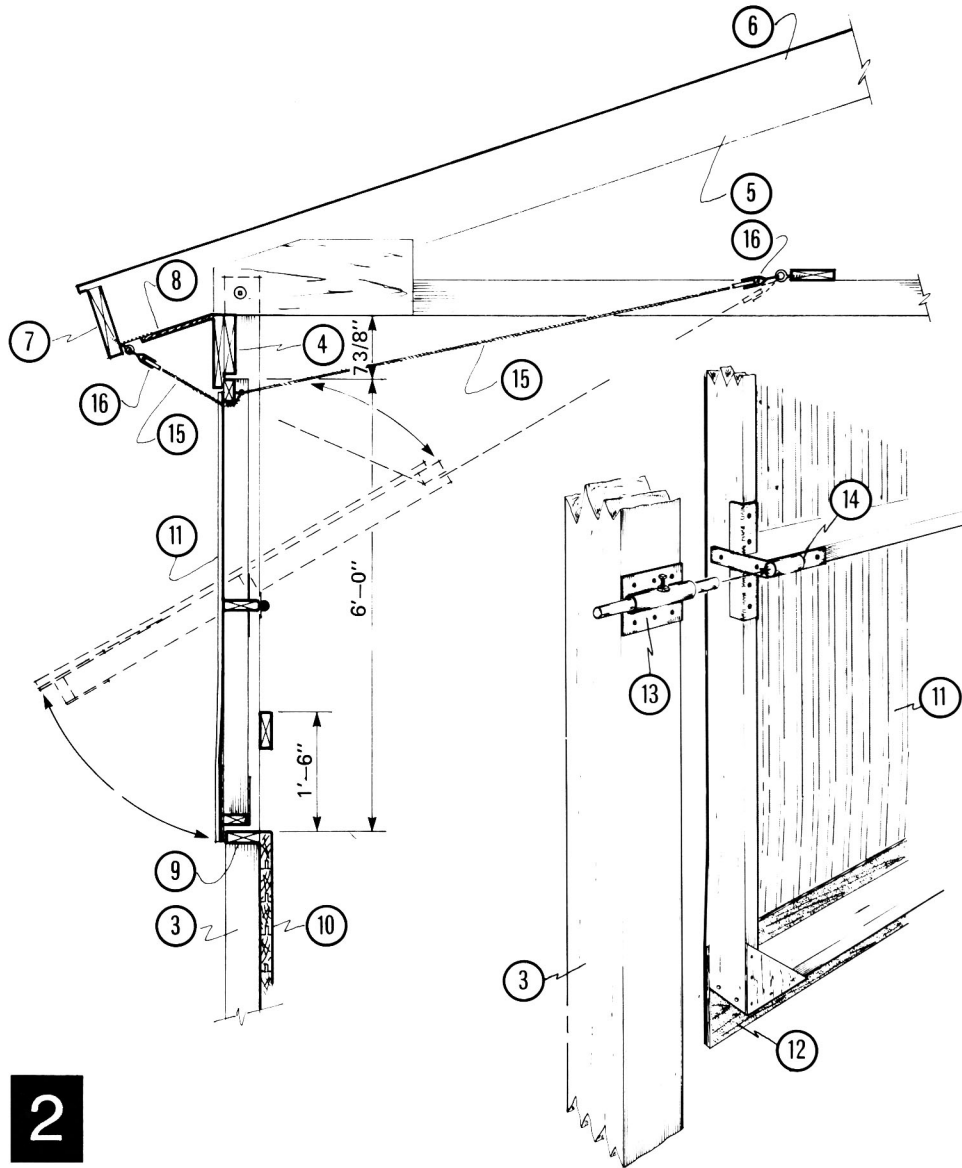

## 2

- 1 control cable diagram; to adjust vent panels, slacken one winch then tighten the other
- 2 pole frame wall section with tilt-in panel
- 3 6" x 6" sawn poles @ 8'-0" oc
- 4 2" x 10" outside plate beam, 2" x 6" scab under; additional 2" x 8" laminated beam notched into pole, see leaflet 9312 for plate beam requirements
- 5 roof trusses to suit local design snow loads, see leaflet 9100
- 6 roof system, insulated to prevent condensation
- 7 2" face board
- 8 3/4" plywood soffit, 2" continuous vent slot
- 9 2" x 6" blocking between poles
- 10 2" x 6" pressure-treated tongue & groove planking to floor
- 11 tilt-in vent panel; metal or other cladding on frame of 2" x 4", 2" x 6" center member notched at ends to fit within frame
- 12 1/2" x 8" exterior plywood sheathing, reinforcing for bottom edge of exterior cladding
- 13 fixed panel pivot from 1/8" x 5 1/2" x 4" drilled plate welded to 1" pipe, 6 lag screws to pole, 1/2" removable pipe pivot secured with set screw and welded nut
- 14 movable panel pivot welded from 1/8" x 1 1/2" steel strap, 1" pipe and 1/8" x 1 1/2" x 1 1/2" steel angle, 8 screws to panel framing
- 15 3/16" nylon or polyester rope, from panel, through pulley (16), cable clamps on cable (17)
- 16 2" nylon marine steering cable pulley @ 8'-0" oc, hooked to 5/16" plated screw-eye, screwed into 2" plank
- 17 3/16" galv. steel cable
- 18 heavy duty marine cheek block
- 19 2 boat winches control one row of panels, both winches lag-screwed to pole just inside barn access door
- 20 counter-weight (optional), maintains cable tension at remote ends; make from a short length of pipe filled with sand