

TILTING SQUEEZE

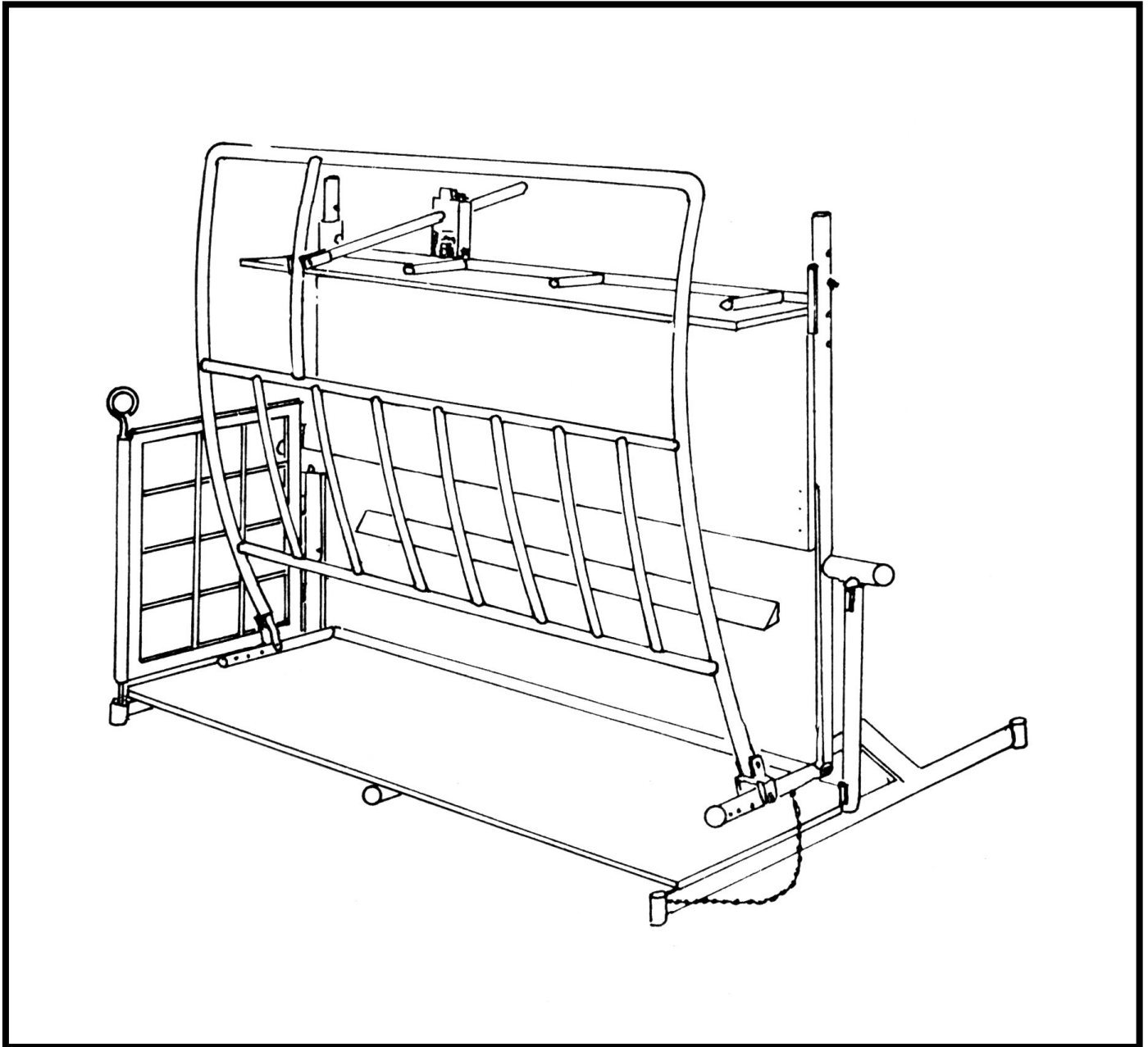

DEVELOPED BY MIDWEST PLAN SERVICE

326-50

TILTING SQUEEZE

This plan calls for all welded steel pipe construction of the frame, side panels and headgate, and plywood panels.

The overall size is 3'-1 1/2" wide, 4'-9 1/2" long, and 3'-0" high.

One side is movable to provide a squeezing action and the bottom width is adjustable to accommodate large or small cattle. The squeeze is controlled by a multiple disc clutch. The back panel pivots to allow the animal to be swung off the ground and the headgate is hinged so that the animal can walk forward after treatment. This feature allows the squeeze to be inserted in a sorting passage.