

POTATO BIN BULKHEAD

COMPLETE INSTRUCTIONS

CPS
PLAN 6122 94:10

DENNIS E. DARBY¹

This plan provides details for bulkheads of sawn wood for closing the front of a bulk potato bin.

Granular materials like grain or potatoes exert both vertical and horizontal forces. Bin fronts have to be designed and constructed to withstand these forces.

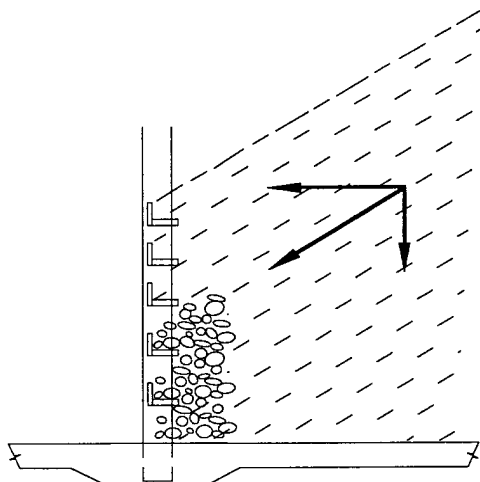

FIGURE 1 POTATO FORCES ARE BOTH HORIZONTAL AND VERTICAL.

Planks are arranged so the potato pressure is in their edge direction for maximum strength; vertical spacers are then required to prevent sagging of planks due to the vertical force of the potato pile.

Strength of the bin system depends on the size and spacing of plank members. Plank size and spacing is determined from the bin design table. A typical bulkhead 16 ft. wide and up to 10 ft. high, may for example, have 2 x 10 planks spaced every 8" for the

first four feet and every 12" above that. Maximum practical spacing is 16 inches; 12 inches is more common.

This type of bulkhead is suited for closing the front of relatively narrow bins, up to 16 ft. wide, and for installation as a bulkhead to hold the potato pile away from large entrance doors of a wide storage.

Bulkhead planks should be easily removed for access to the bin. It is a challenge to incorporate ease of removal when the bin is full and the bin members are under pressure. For plank-type bulkheads like these, it is not simply a matter of "pulling the latch" at the end of the lower planks, for this would cause the upper one to break.

Two solutions to this are illustrated. One is to incorporate a small removable section within the main bulkhead (detail 7). The other is to shopweld a short removable steel post to support the upper planks (detail 10).

Supports for the end of the bulkheads must be of substantial strength. This could be either the side walls of the bin, or independent posts of steel or heavy timber. The plan provides details for steel post support systems.

For free-standing bulkheads (meaning they are simply a post in the floor), steel post sections can be selected from the design table. These steel posts are designed to be anchored in a well-reinforced section of the concrete floor. A steel sleeve (detail 12) can be added to make the post removable.

If bin front columns are anchored to a ceiling of adequate strength, or tied securely back to the walls side, the bending stress is less than that for a post-type column, and thus could be smaller. Consult an engineer for this design

DEVELOPED BY CANADA PLAN SERVICE

¹ Alberta Agriculture; Lethbridge, Alberta

BULKHEAD DESIGN TABLE

LUMBER #2 S-P-F

BULKHEAD SPAN - m (ft)	PILE DEPTH m (ft)	SIZE OF SAWN LUMBER BULKHEAD PLANK SPACING- mm (in)		
		200 (8")	300 (12")	400 (16")
2.4 (8)	1.2 (4)	2 x 6	2 x 6	2 x 6
	2.4 (8)	2 x 6	2 x 6	2 x 6
	3.0 (10)	2 x 6	2 x 6	2 x 8
	3.6 (12)	2 x 6	2 x 8	2 x 8
3.6 (12)	1.2 (4)	2 x 6	2 x 6	2 x 6
	2.4 (8)	2 x 8	2 x 8	2 x 10
	3.0 (10)	2 x 8	2 x 10	2 x 12
	3.6 (12)	2 x 10	2 x 12	2 x 12 or 3 x 10
4.2 (14)	1.2 (4)	2 x 6	2 x 6	2 x 8
	2.4 (8)	2 x 8	2 x 10 or 3 x 8	2 x 12 or 3 x 10
	3.0 (10)	2 x 10	2 x 12 or 3 x 10	3 x 10
	3.6 (12)	2 x 10	3 x 10	3 x 12
4.8 (16)	1.2 (4)	2 x 6	2 x 8	2 x 8
	2.4 (8)	2 x 10	2 x 12 or 3 x 10	3 x 10
	3.0 (10)	2 x 10	3 x 10	3 x 12
	3.6 (12)	2 x 12 or 3 x 10	3 x 12	---

Design is based on pressure 0.3 m (12") from bottom of pile
 Example: for 12' span, pile 8' deep, use 2 x 8 @ 12" OC or 2 x 10 @ 16" OC

SIZE OF STEEL BULKHEAD POSTS

At each end of a clear-span bulkhead

BULKHEAD SPAN - m (ft)	PILE DEPTH m (ft)	SQUARE STEEL (IMPERIAL UNITS)	STEEL PIPE OD x THICKNESS (IMPERIAL UNITS)	WIDE FLANGE BEAMS (METRIC)
2.4 (8)	2.4 (8)	4 x 4 x 3/16	4.0 x 1/4	W150 x 14
	3.6 (12)	5 x 5 x 1/4	6.62 x 1/4	W150 x 18
3.6 (12)	2.4 (8)	4x4x 1/4	4.50 x 1/4	W150 x 14
		5 x 5 x 3/16	5.56 x 3/16	W200 x 15
	3.6 (12)	6x6x 1/4	6.62 x 5/16	W250 x 22
4.2 (14)	2.4 (8)	7 x 7 x 3/16	8.63 x 1/4	W200 x 22
		4 x 4 x 1/4	5.56 x 1/4	W150 x 14
	3.6 (12)	5 x 5 x 3/16	5.56 x 1/4	W200 x 15
		6 x 6 x 3/8	8.63 x 1/4	W250 x 22
4.8 (16)	2.4 (8)	7 x 7 x 1/4	8.63 x 1/4	W200 x 27
		4 x 4 x 1/4	5.56 x 1/4	W150 x 14
	3.6 (12)	5 x 5 x 3/16	5.56 x 1/4	W200 x 15
		6 x 6 x 3/8	8.63 x 1/4	W250 x 22
6.0 (20)	2.4 (8)	7 x 7 x 1/4	8.63 x 1/4	W200 x 27
		5 x 5 x 1/4	5.56 x 1/4	W200 x 15
	3.6 (12)	7 x 7 x 3/8	8.63 x 3/8	W250 x 22
				W200 x 27

NOTE: (1) Post design is for a post at each end of a plank bulkhead. For a post in centre of a bulkhead, use 2x the spacing at either side.
 Posts are anchored in floor, not supported at the top.

(2) Wide flange beams are metric designations.

(3) The larger steel posts require well-reinforced concrete floor sections to withstand the large overturning forces.

The Canada Plan Service, a Canadian federal/provincial organization, promotes the transfer of technology through factsheets, design aids and construction drawings that show how to plan and build modern farm structures and equipment for Canadian agriculture.

For more information, contact your local provincial agricultural engineer or extension advisor.

WARNING This leaflet gives structural choices you must select to meet local climatic loads (wind, snow), soil-bearing capacity and other local conditions.
 You must ensure that these requirements are met. Consult an engineer if you are not familiar with the details required

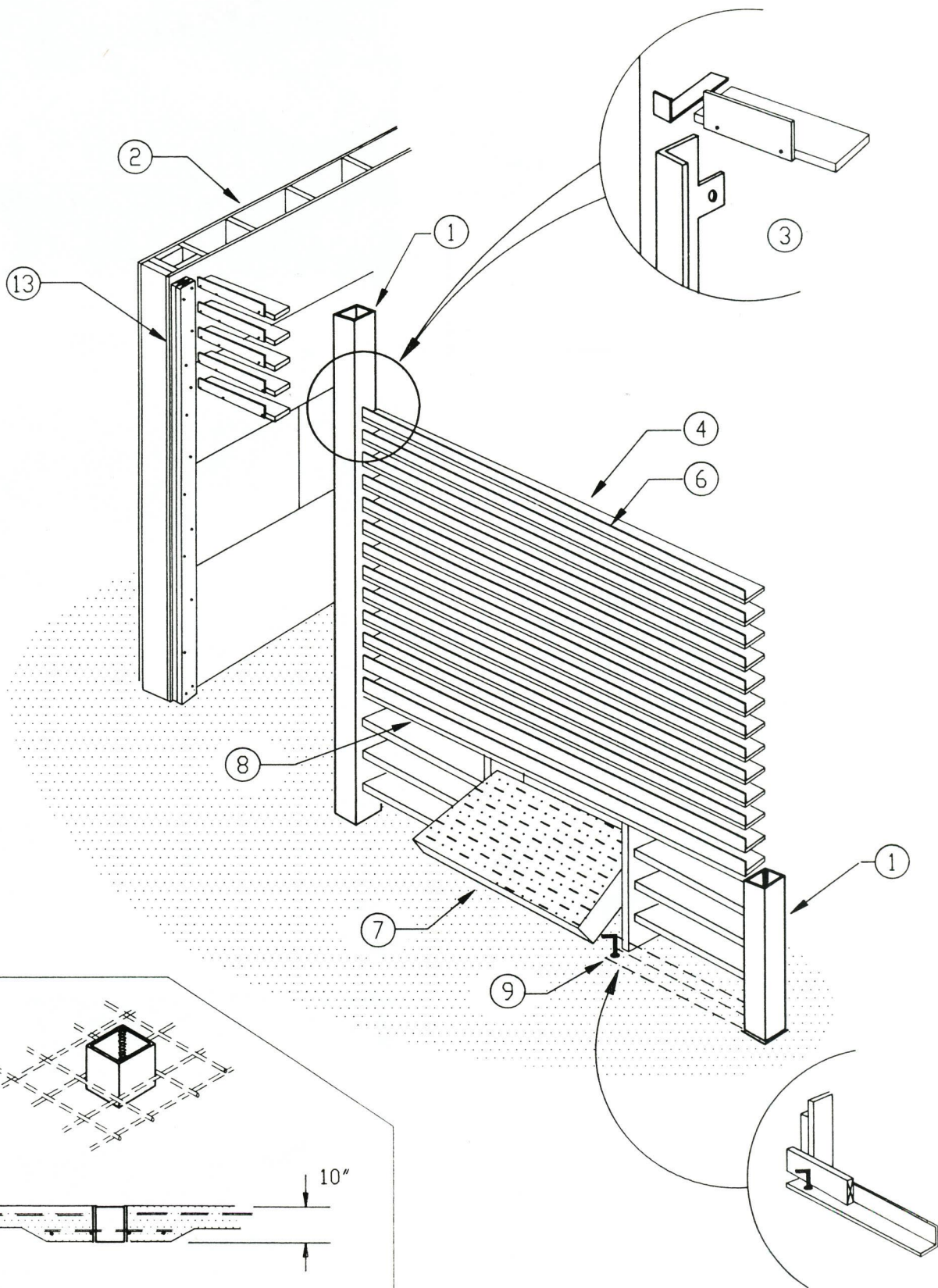

Designed: D.E.D.
 Drawn: D.E.D.
 Date: 1991/09
 Scale:

Plan
STORAGE BULKHEAD
 Sheet of



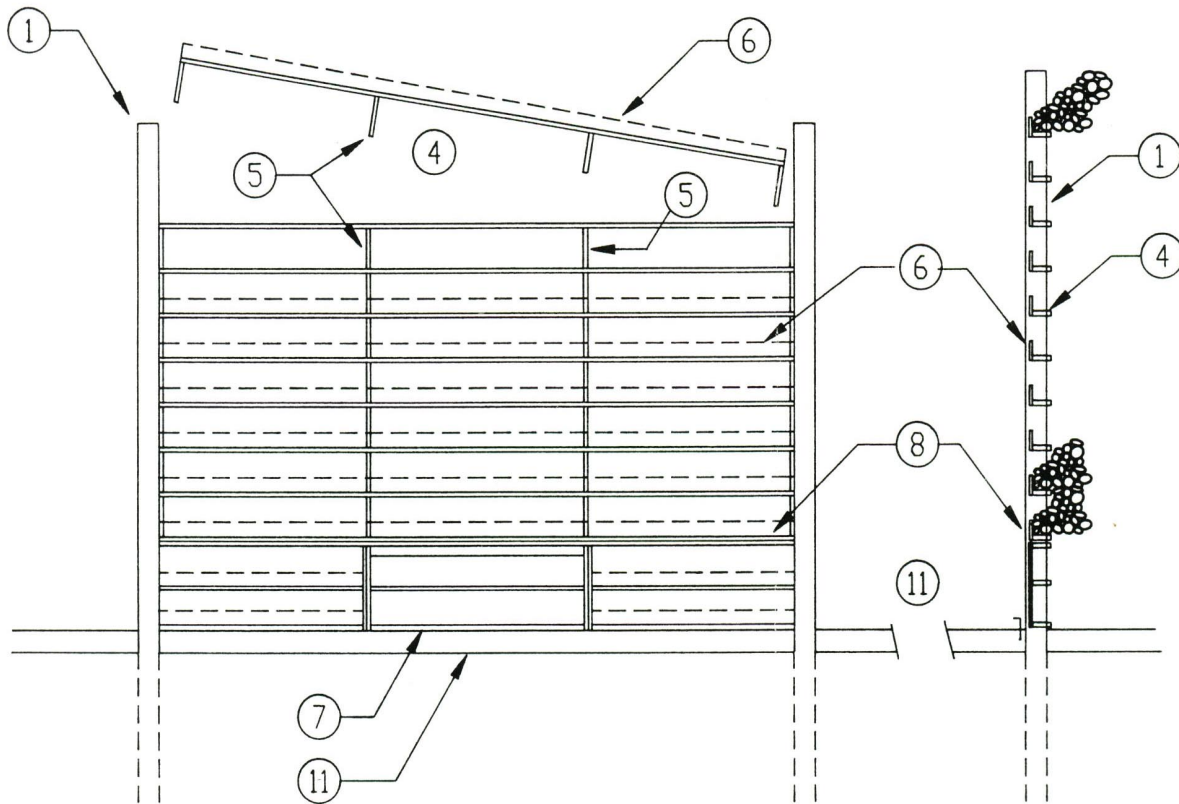
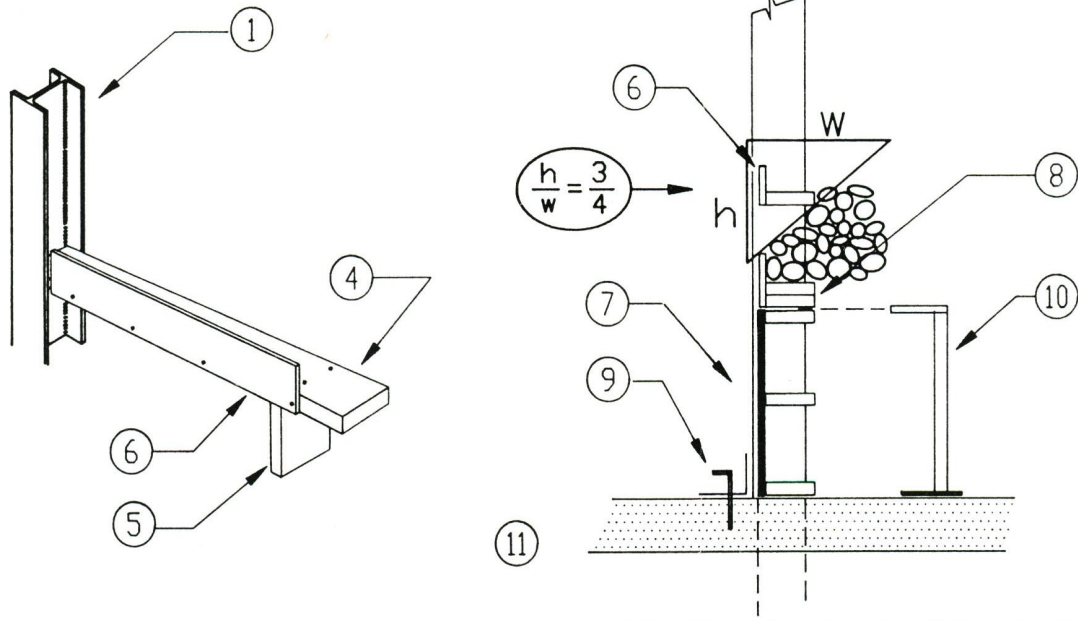

NOTES FOR DRAWINGS ON PAGE 3 AND 4

1. steel bulkhead posts, HSS or WF column
2. bulkhead between bin walls
3. attachment methods for square steel post
4. individual plank sections, see table for size and spacing
5. vertical supports spaced 5' max.
6. retainer board
7. removable starter section

8. double members at top of ⑦
9. pin and L-iron to support ⑦
10. fabricate a steel support for upper panels if ⑦ is full width
11. concrete floor
12. reinforced inser for ① 15M bars
13. retainer cleat, 2-2 x 6, bolt to ②