

SHEARING TABLE

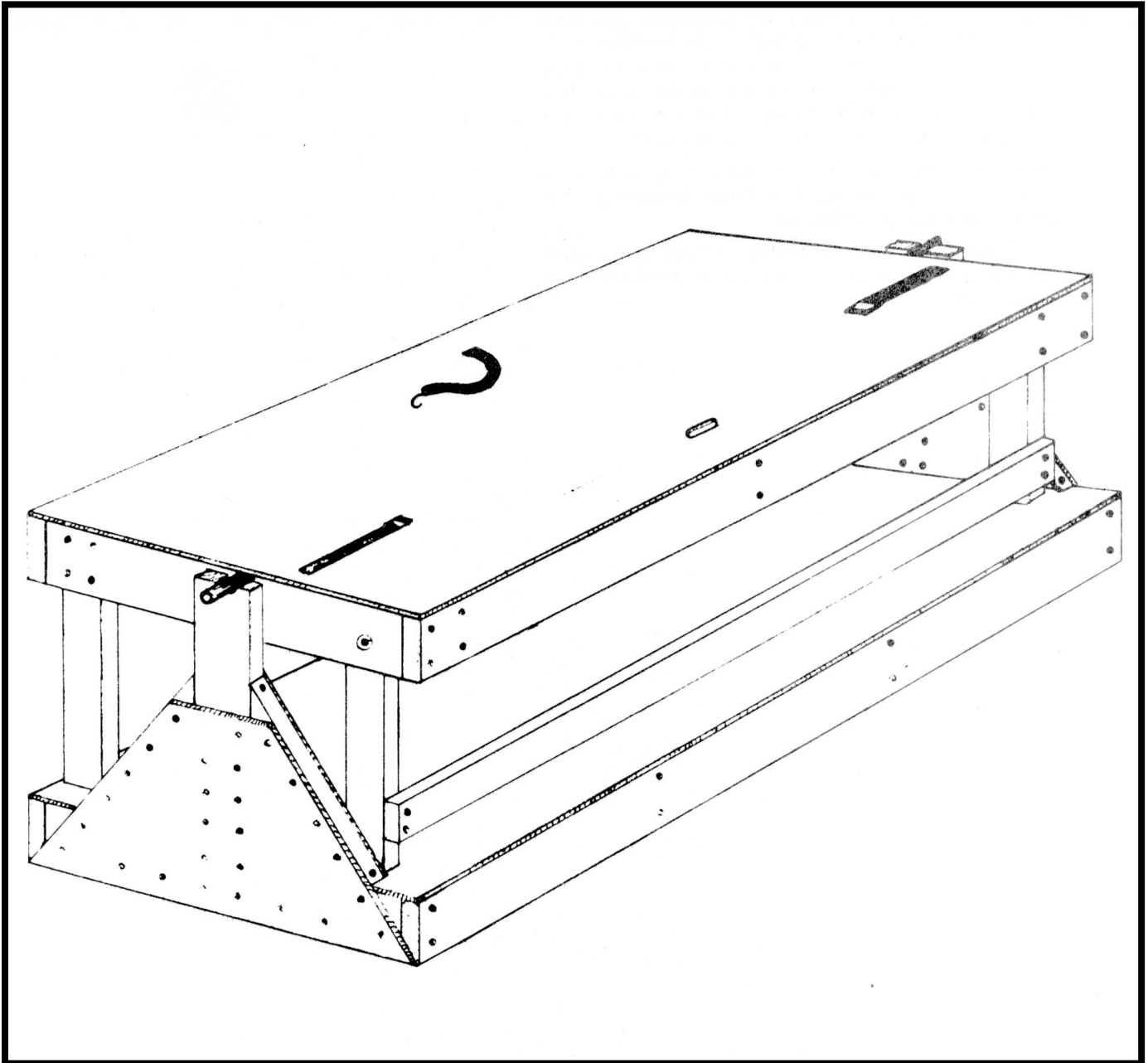

DEVELOPED BY CANADA PLAN SERVICE

353-52

SHEARING TABLE

CPS

PLAN 4551

NEW 11:75

This shearing table was developed by John Lightle, Campbell-ford, Ontario. John runs a flock of around 400 ewes. Using his shearing table he is able to trim the feet and shear about 6 ewes per hour including rolling and packing the wool.

The Table part tips at right angles to the base by kicking out the two legs on the side nearest the operator. The sheep is temporarily fastened with a rubber strap around the middle. The table is tipped back to the horizontal position and the sheep is secured by two leather straps. One strap holds both front legs and the other both rear legs. This holds the

sheep in a stretched position. The belly strap is then removed and the shearer can roll the sheep from one side to the other while being sheared. The sheep is actually rolled right out of the fleece without having to release any of the leg straps.

Shearing is a highly skilled job and many sheep owners are discouraged from expanding their flocks because of the difficulty in obtaining good shearers.

While this shearing table will not substitute for a good custom shearer, it might help the small flock owner do the job himself, at a slower pace.