

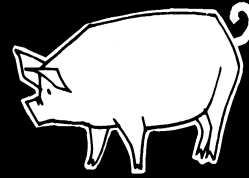

BRITISH
COLUMBIA

Ministry of Agriculture, Food and Fisheries

Agricultural Building Systems Handbook



PLAN

362-63

WELDED STEEL FARROWING STALL

COMPLETE INSTRUCTIONS

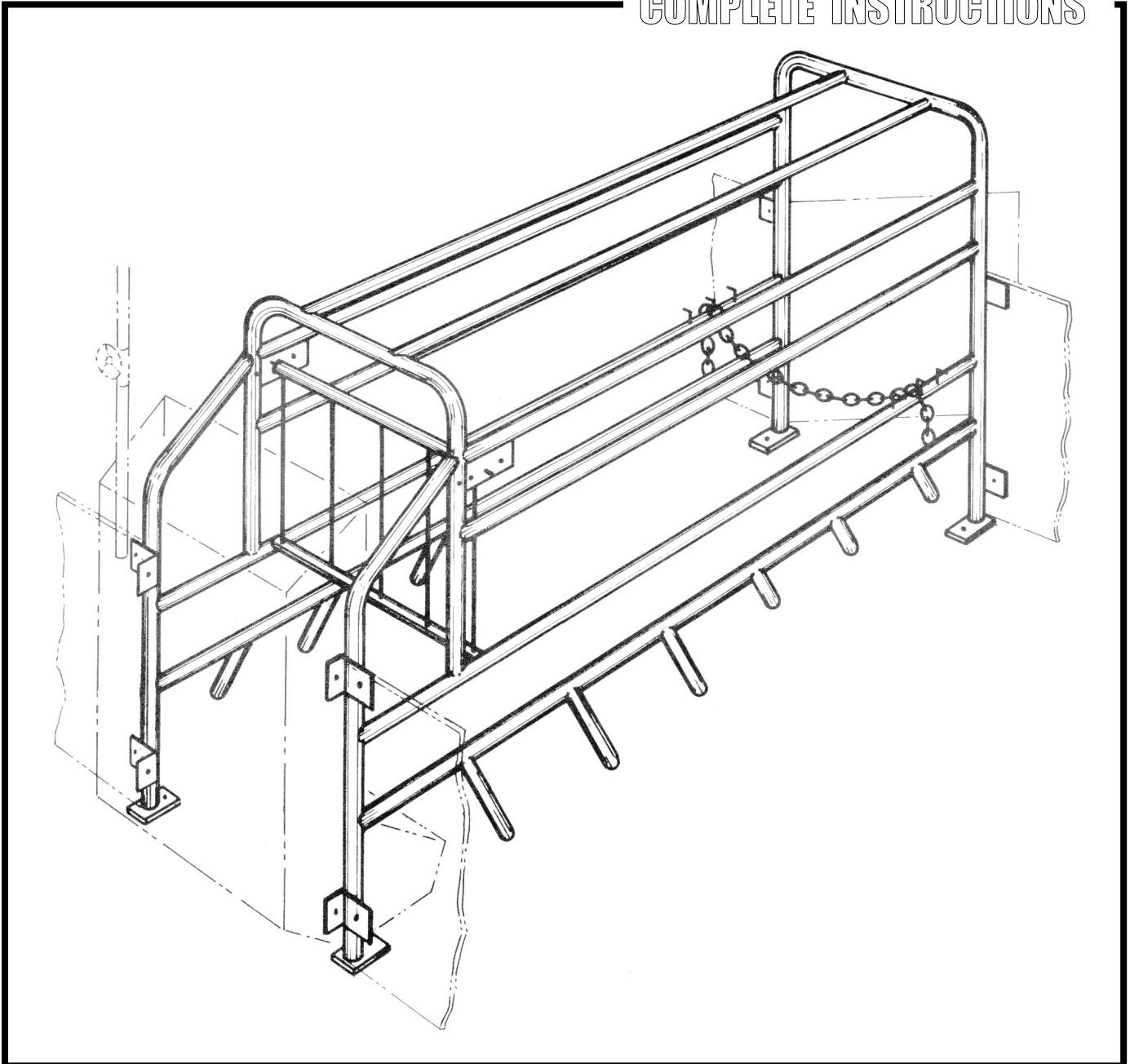

DEVELOPED BY CANADA PLAN SERVICE

WELDED STEEL FARROWING STALL

CPS
PLAN 3812 REVISED 84:01

This is a farm-tested farrowing stall design which can be made in an ordinary well-equipped farm shop. It can be used in a variety of farrowing pen arrangements (see Plan 362-62) with minor modifications to suit the arrangement of rear gate, baby pig creeps etc. Several special features of this stall are worth mentioning here, as follows:

SOW RETAINER BAR WITH FINGER GUARDS This is a considerable improvement over earlier designs, since it eliminates the need for adjustment up or down to accommodate different sows.

SWINGING HEADGATE This small free-swinging headgate gives the sow easy access to the feed hopper, but gently reminds her to step back when not

feeding. The net result is that manure drops more consistently in the same area at the rear of the stall, and the sow's udder stays cleaner. Used with a slotted floor at the rear part of the stall, the sow can be kept even cleaner.

FEED HOPPER AND WATERER The feeder is usually folded from heavy-gauge galvanized sheet steel, reinforced at the edges; this part is much easier to build with metal shearing and bending machines, and is probably best made by a tinsmith shop. A simple way to water the sow is by a valve and pipe leading down into the feeder from overhead. If an automatic drinker nozzle is preferred, mount it over the feed hopper but below the arc of the swinging headgate ⑤.

THE STEEL FRAME Use either round pipe or square structural tubing as specified. The square tube is easier to fit together for neat, welded connections, so most builders prefer it over pipe. However, the lower pipe guardrail and angled finger guards should be round pipe.

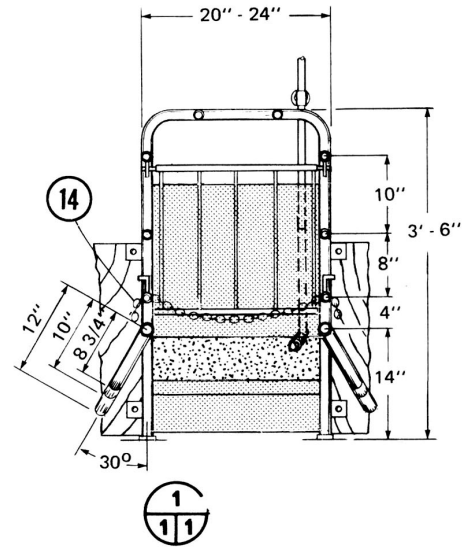
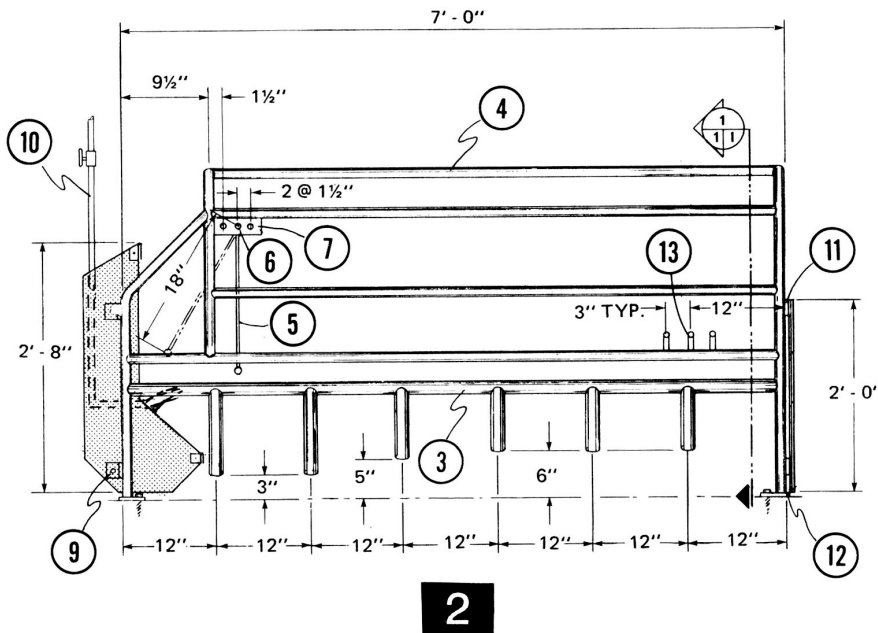
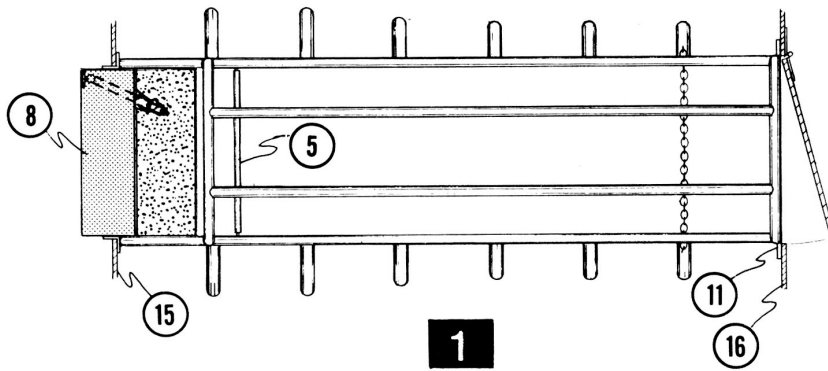

1. plan view
2. side view
3. bottom pipe and finger guards from 1" pipe; make guard ends blunt and smooth
4. frame welded from 3/4" pipe 1" x 1" x 1/8" square structural tubing unless otherwise noted
5. swinging head gate welded from 3/8" rod verticals and 3/8" pipe top & bottom
6. pivot pin from 3/8" rod, drill ends for cotter keys
7. adjustable pivot plate 1/4" x 1 1/2" x 6" drilled for ⑥
8. feed hopper from 20 ga. galv. sheet steel; all edges exposed to sow made smooth and reinforced by folding sheet steel around 1/8" x 1" flat steel, ends turned and riveted
9. tabs from 1/8" x 2" x 2" steel angle 2" long, weld to stall and bolt to ⑧ and ⑮
10. water supply
11. tabs from 1/4" x 2" x 2" flat steel for bolting rear pen panels
12. welded floor plates from 1/4" x 2" x 3" flat steel, drill for anchor bolts to floor system
13. chain hooks from 3/8" dia. steel rod
14. adjustable rear chain
15. front pen panel
16. rear pen panel