

## FENCE POSTS

### Materials, Installation and Removal

Fence posts are principally used to support and space the fence wire to contain or direct animal movement. They must be strong enough to resist pressures exerted on the wires. Furthermore, posts must have a long life expectancy by resisting decay, rotting or rusting. They must be relatively easy to install and to attach wires to, and they must do all of this at a reasonable cost.

#### WOODEN POSTS

The most suitable and most used material for agricultural fence posts is wood; specifically round, chemically pressure treated softwood, such as Lodgepole Pine. The principal reasons for this preference are that wooden posts are in good supply in B.C.; they have a high strength to relatively low weight ratio; are economical and provide a long service life. As well, they can be driven into the soil with power equipment and the fence wire can be easily stapled to wooden posts.

#### Wooden Post Strength

Experience in fence construction is used when selecting wooden post materials and sizes for various fence requirements. Line posts, brace posts, etc. are sized for the load they are expected to resist. Figure 1, below, indicates the approximate breaking strength of pressure treated pine posts, the most commonly used in B.C.

Split cedar is also used for fence posts (especially in coastal areas where the wood is common). It may be selected for organic farms as it can be used untreated. Table 1, page 2, indicates expected life for untreated first growth cedar. Choose a split post with a triangular cross section that could contain the round post size recommended for the required use.

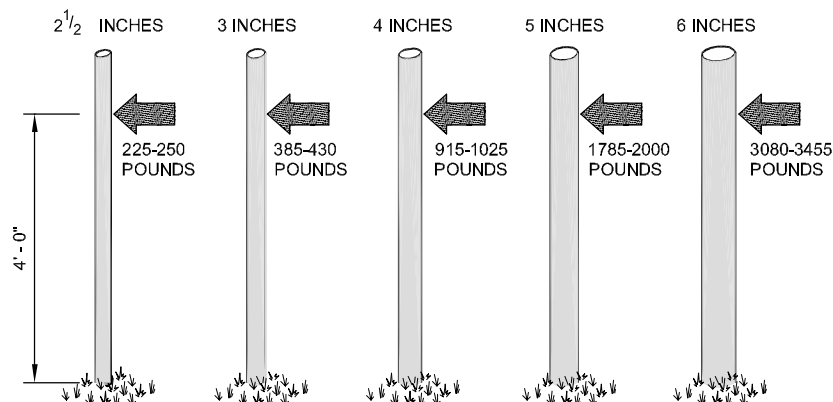

APPROXIMATE BREAKING FORCES ARE FOR PRESSURE TREATED  
PINE POSTS WITH LOADS STEADILY APPLIED.

FROM US STEEL  
"MAX TEN 200"

**Figure 1 Pine Fence Post Strength**

## Wood Decay

The biggest disadvantage in using wood as fence posts is the fact fungi attack and decay wood to the point where the post no longer has the required strength (see Table 1, below). However, fungi can only grow and cause decay if the correct conditions of moisture, air supply, temperature and most importantly, food supply, exist. Various treatments are available to greatly reduce fungal growth and extend fence post life.

Wood maintained at 20 percent moisture or less will not decay nor will wood deep in the ground where oxygen is very low. However, optimum conditions for fungal growth occur in a zone approximately one foot above and below ground level. This is also the area where maximum fence post strength is required. As shown in Table 1, below, only cedar should be considered for use untreated for fence posts.

<b>Table 1 LIFE EXPECTANCY OF UNTREATED WOODEN POSTS (HEARTWOOD)</b>	
<b>Wood</b>	<b>Untreated Life (years)</b>
Cedar (1 <sup>st</sup> growth)	20 - 30
Tamarak	10 - 15
White Pine	8 - 12
Douglas Fir	7 - 12
Birch	5 - 10
Willow	5 - 8
Ponderosa Pine	4 - 14
Lodgepole Pine	4 - 12
Spruce	4 - 6
Poplar	3 - 5

From: USDA and Alberta Agriculture

## Wood Treatments

An “old time” wood treatment method involves the use of fire to char the surface of the wood that will be in ground contact. While slow it was an inexpensive treatment when used for a few poles, for instance in barn construction. It would not be practical to consider this method for the number of posts required for fencing.

Most all other treatments involve the use of chemicals that make the wood toxic to fungi, removing it as a food source. There are two distinct application methods:

- **Soaking Treatment** - a suitable on-farm method
- **Pressure Treatment** - commercially applied in a pressure tank

Treatment is rated by the amount of chemical absorbed into the wood. The depth of penetration is not necessarily an indicator of the quality of treatment. **Pressure treatment is by far the most effective method of applying wood preservative chemicals.** Only when on-farm posts are available at little or no cost should a soaking method be considered. Even then it may be better to have them pressure treated. Refer to MAFF publication *Wood Preservation on the Farm*, #378.600-3.

## Treatment Chemicals

While there are a wide variety of wood preservatives used for fence posts, they fall into two distinct categories. Those marked <sup>1</sup> are chemicals used by pressure treatment plants. Only CCA is now commonly used.

**Oil-borne Preservatives.** These are not water soluble:

- **creosote<sup>1</sup>** - effective, low cost, noncorrosive to metals; strong odor, oily, irritating to the skin, can leach out of the post
- **pentachlorophenol<sup>1</sup>** - penta or PCP; environmental concerns limit use
- **copper naphthenate** - green cuprinol
- **zinc naphthenat** - clear cuprinol

**Water-borne Preservatives.** These are water soluble:

- **chromated copper arsenate<sup>1</sup>** - CCA; does not leach out once dried in the post
- **ammoniacal copper arsemate** - ACA; does not leach out once dried in the post
- **copper sulfate** - Bluestone; will leach out of post reducing effectiveness

Other materials, such as coal tar, crude petroleum, fuel oil and diesel, when used alone, have very little preservative value.

## Safety Concern

Posts treated with any of the preservatives and then dried before use are unlikely to cause more than minor skin irritation when handled. Nevertheless, it is advisable to use gloves when handling treated wood, particularly if it was treated with oil-borne preservatives such as creosote or pentachlorophenol.

## Wooden Post Sizes

Wooden posts are sized by the diameter range (inches) x length (feet):

- 2 to 3 inch x 6 to 8 feet (electric fence line posts)
- 3 to 4 inch x 6 to 10 feet (standard livestock fence line posts)
- 4 to 5 inch x 8 to 10 feet (standard braces or game fence line posts)
- 5 to 6 inch x 8 to 11 feet (game fence braces)

Posts are normally peeled, pointed and domed before pressure treatment. Domed posts have the “corner” removed from the top end to reduce splintering from the post driving impact.

## OTHER POST MATERIALS

Although wood is the most common material for agriculture fence posts, three other materials are used as well; steel, concrete and standing trees. Special posts used in electric fencing are discussed on page 5.

### Steel

Steel posts are formed into a T, U or Y cross section and are either studded or punched with holes. They are available in lengths from six to eight feet and weigh 1-1/4 to 1-1/3 pounds per foot. The line wires are usually wire tied to the post at a stud or hole. Steel posts are lighter to work with, easier to drive into the ground, but not as strong and often more expensive than wooden posts.

Some steel posts have an optional flat metal “spade” or anchor plate that is positioned part way up the post. This plate should be parallel to the fence line and 4 in to 6 in below the soil surface when the post is driven in. It will help prevent failure of the post by providing a greater soil contact area.

There are also specially formed steel posts that allow stapling of the fenceline wires. The cross section springs open and grips the staple. They are available under trade names such as “Staple Gripper” (that uses standard staples), or “Staple Loc” (that uses a special staple). Some claim to be 2 to 2-1/2 times stronger than standard steel posts due to their larger cross section.

Steel posts can be used to build brace assemblies in lightly loaded fences. Specially formed connectors for T-posts are used to form horizontal or diagonal braces. This “Wedge-Loc” system uses collars and wedges to construct post-to-post connections.

## Concrete

Posts of concrete are used that are either farm or factory produced. When produced with the proper ratio of cement, sand, aggregate and water, in conjunction with reinforcing, they will have the following characteristics.

### Advantages of Concrete Posts:

- very long life; no rot or corrosion
- will not burn
- environmentally safe—no preservative chemicals used
- uniform, attractive appearance
- can be painted
- can be cast on farm

### Disadvantages of Concrete Posts:

- heavy; approximately 50 pounds or more each
- cast-in place staple inserts require posts to be driven to appropriate depths
- the staple inserts must face the right direction
- the staple inserts must be prelocated for the required wire spacings

Concrete posts can be driven into the ground using standard post drivers. The use of a rubber or steel driver cap prevents damage to the top of the post. Posts are formed with a pointed end.

## Standing Trees

The use of trees along the right-of-way as fence posts is not usually recommended. Trees are growing and expanding continuously and are not suitable as posts. However if unusual conditions require the use of trees (such as rocky or swampy areas), the wires cannot be stapled directly to the tree. To prevent the wires from becoming “in-grown” a sturdy wooden nailer such as a rough cut 2x4 is first nailed to the tree and fence wires are stapled to the nailer. Use 5 or 6 inch ardox (twist surface) nails and do not drive them home but allow some “slack” so the 2x4 can still move slightly as the tree grows (expands). An inch or two of exposed nail is suggested. Some heavy bark can be removed before the nailer is installed.

Nailers are also used if wire is to be wrapped around the tree to prevent choking or eventually killing the tree. Use five or more nailers spaced around the tree.

## POSTS FOR ELECTRIC FENCES

Because an electric fence is a psychological not a physical barrier, the fence posts do not require high strength. Post material may be chosen for insulation value, for instance fiberglass instead of steel posts. Post sizes will vary for permanent or temporary fences.

### Posts for Permanent Electric Fences

Permanent electric fences are usually designed for long life using durable materials. Any savings gained by using lightweight posts may be at the expense of shorter life. Many permanent electric fences are constructed using pressure treated wooden posts one diameter size smaller than standard, i.e. brace posts at 3 to 4 inch diameter and line posts at 2 to 3 inch. Standard insulators can be nailed to these posts. Some permanent electric fences may use standard post sizes.

### Posts for Temporary Electric Fences

Temporary electric fences are often built to be moved easily and benefit from the use of special posts. These posts will be:

- lightweight - a bundle can be carried easily
- easy to install - with a light pipe pounder or hammer; some have a plate for pushing in by foot
- may be insulating - if made of fiberglass, line insulators are not required
- may use special insulators - steel rod posts used with adjustable (sliding) insulators

Typically, posts for temporary electric fences are made of an insulating material such as fiberglass and are easy to install (without tractor equipment). Because of the small diameter of many of these posts, some offer an option anchor plate similar to those on steel fence posts. This plate should be parallel to the fenceline and 2 in to 4 in below the soil surface when the post is set. It will help support the post should livestock contact it. This contact, if the fence is properly electrified, should be infrequent.

## INSTALLATION OF FENCE POSTS

A variety of equipment and methods are available to install fence posts quickly and efficiently for a wide range of post sizes and soil conditions. These methods can be summarized into the following three categories:

- dig and fill - hand dug with compacted fill; auger dug with compacted fill
- drive in - hand raised/dropped weighted driver; machine driven ram with a friction, pneumatic or hydraulic drive
- vibrate in - hydraulic driven vibrator; assisted by a weighted head or hydraulic pressure

Combinations of these methods are sometimes used, for instance partly dug and then driven in when the post height is greater than the drivers capacity. As a rule of thumb, approximately 1/3 of the full line post length should be inground; for brace posts 1/2 the length (to 4 ft maximum).

### Dig and Fill

Posts set in this manner have less resistance to uplift than posts driven or vibrated in. This method is not recommended for brace posts or line posts in dips, but is sufficient for standard line posts.

Posts are set in the oversized holes, large diameter end down with backfill material placed and compacted in 6 inch layers. If this method must be used for brace or dip posts, a foot and/or thrust block can be installed, as the post is backfilled.

In cases where very hard ground is encountered, digging can be made easier if partial holes are filled with water and left to stand overnight. The saturated ground will be easier to dig the following day.

## **Drive In**

Posts set in this manner have good resistance to uplift. Equipment varies from one to two man hand drivers (weighted pipe, with handles, that slides over the post) to tractor 3-point hitch mounted drivers. Machine drivers are preferred whenever the right-of-way terrain allows equipment access. Hand drivers are effective only on steel posts or small diameter pointed wooden posts.

Driven posts are installed small diameter end down. The natural taper of the post ensures increased ground pressure is exerted by the soil as the post is driven in. This increases uplift resistance. Large diameter posts (greater than 6 inch) may require an augured pilot hole prior to driving in some firm soils.

## **Vibrate In**

In recent years, an improved post setting method has been demonstrated by a Kamloops inventor. Ken Fraser of Red Top Construction found that posts could be installed faster and with less post damage than the weighted driver method by using vibration. Hydraulically driven eccentric weights in a weighted “head” produced sufficient vibration to set most any post size. He has used this idea to install miles of fence. Recently the principle has been used by modifying standard vibrating soil compactors suspended in place of the bucket on excavators. Much of the highway game fencing on interior freeways (7 inch posts x 14 feet) has been installed with this method.

These units also have the ability to form a pilot hole by vibrating in a steel pipe slightly smaller in diameter than the post. They can work in frozen ground and have good ability to control the post angle in most any terrain.

## **Safety Concerns**

Fence post drivers must be treated with respect. Considerable forces are in play in driving a post into the ground and posts often splinter. Precautions include gloves for hand protection, goggles for good eye protection and steel toe boots. Refer to Factsheet #307.050.3 for Workers' Compensation Board and general safety concerns.

Many post drivers are supplied with a “steady fork” to be used rather than the operators hand in holding the post while driving. Also, beware that some hydraulic valves may be accidentally bumped activating the drive cylinder.

## **REMOVING POSTS**

When a post is removed, energy should be applied in a direct upward direction sufficient to counteract the post/soil resistance. Any effort that causes the post to move in an arc must displace soil and therefore will require extra effort. For this reason, successful post pullers use either direct hydraulic uplift or a lever with a small arc on the post arm. In some cases, arcing will damage or break a post.

The larger the post and the drier/harder the ground, the larger the effort required to remove the post. Steel posts will usually be the easiest to remove.

**Note:** In all cases when removing posts, wear safety goggles and gloves. Use caution as significant forces are involved. Posts may suddenly release and move towards the operators.

## Lever Style Removers

These have a leg with a ground foot and a head that grasps the post. An arm, which the user operates, applies pressure through a lever action applying an uplift force to the post. One model has a head specifically to grip the notches of a steel post. A lever type post remover is shown in Figure 2, below, that uses heads sized for the post, whether steel or wooden.

## Hydraulic Style Removers

These may be homemade devices (low cost, one to three ton hydraulic jacks rigged in tandem on each side of a post) or the hydraulic system of a tractor (either the loader or rear hydraulics). There is a device that hangs by chains from a tractor front end loader that can remove steel posts allowing the operator to remain in the tractor seat.

A heavy duty hydraulic cylinder device is manufactured to remove posts of all sizes. Typically, these or the tractor methods use a chain wrapped tightly around the post so as to grip when pulled upward.

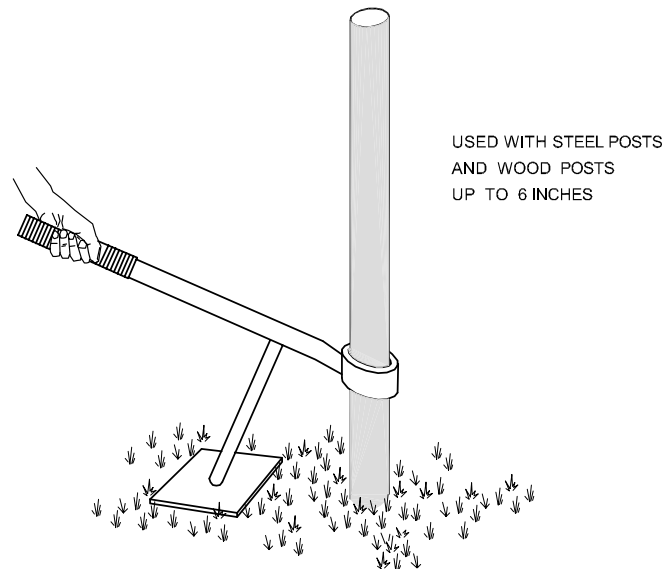

**Figure 2**      **Lever Style Post Remover**

For further information on related topics, please visit our website

**Resource Management Branch**

[www.agf.gov.bc.ca/resgmt](http://www.agf.gov.bc.ca/resgmt)

Linking to our

[Publications and Conceptual Plans](#)

---

### FOR MORE INFORMATION CONTACT

Lance Brown, Regional Engineering Technologist  
Phone: (250) 371-6064  
Email: [Lance.Brown@gems6.gov.bc.ca](mailto:Lance.Brown@gems6.gov.bc.ca)

### RESOURCE MANAGEMENT BRANCH

Ministry of Agriculture, Food and Fisheries  
1767 Angus Campbell Road  
Abbotsford, BC V3G 2M3 Phone: (604) 556-3100