

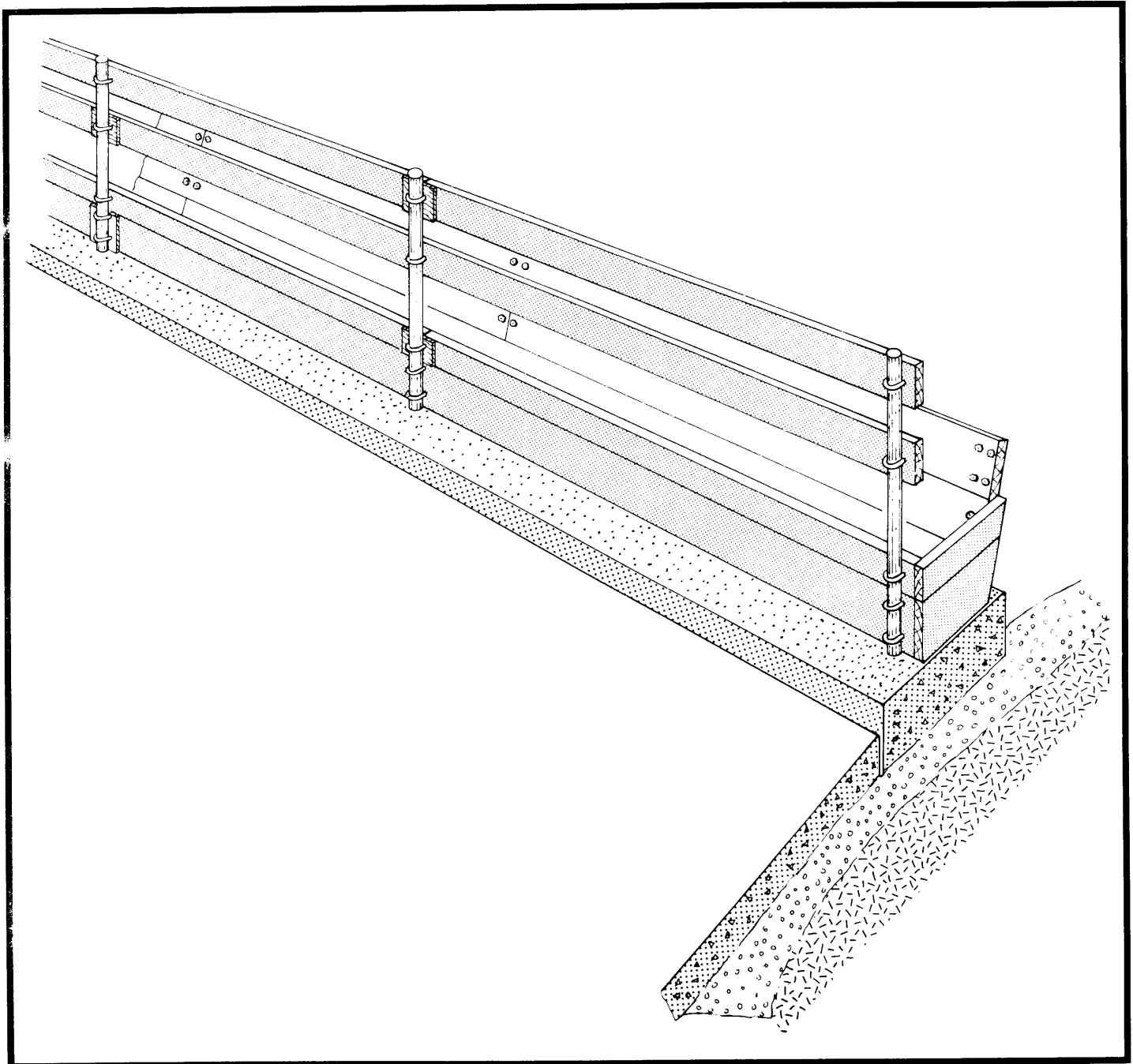

SHEEP FENCELINE FEEDER , STEEL POSTS



The Canada Plan Service prepares detailed plans showing how to construct modern farm buildings, livestock housing systems, storages and equipment for Canadian Agriculture.

This leaflet gives the details for a farm building component or piece of farmstead equipment. To obtain another copy of this leaflet, contact your local provincial agricultural engineer or extension advisor.

SHEEP FENCELINE FEEDER, STEEL POSTS

PLAN M-4616 NEW 78:11

The back of this leaflet gives details for a combination feedlot perimeter fence and feed bunk. This is designed for feeding concentrates and chopped roughages from a self-unloading forage wagon, mixer truck or mobile feed mill.

This feed bunk is framed with galvanized pipe posts set into a raised concrete base. For accurate positioning of the posts in concrete, make a welding jig and preassemble the posts in pairs by welding them to short steel rebars. Then support the posts

between the concrete forms, wire the longitudinal rebars, and pour the concrete base.

For the feed fence and sloping bunk front, use either dressed 38 mm planking or rough-sawn full 25 mm boards. Fasten the boards to the pipe posts with galvanized U-bolts. To adjust for small or large sheep, slacken the U-bolts and slide the feed fence board up or down.

A 200 x 75 mm concrete step and a sloping strip of pavement along the feed bunk gives firm dry footing for the sheep. Make the paving at least as wide as the tractor used for feedlot scraping and cleaning.

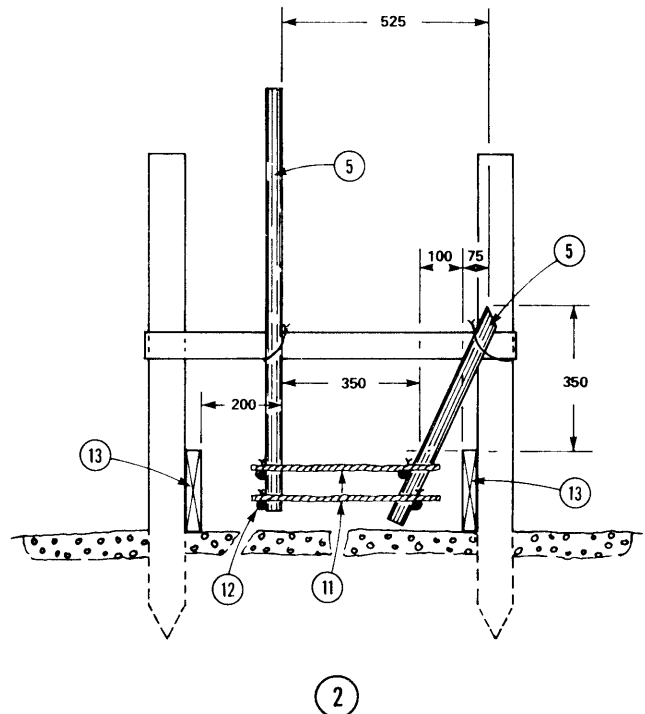
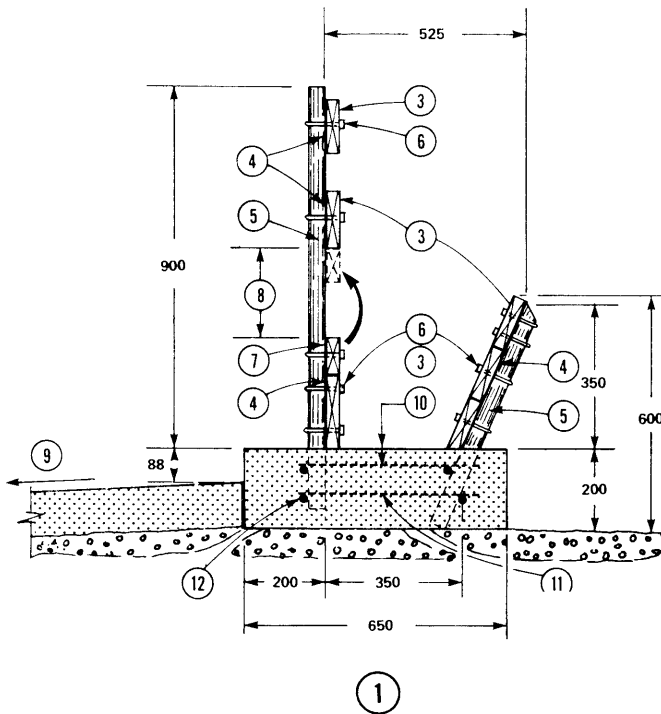

1. cross section

2. cross section showing method of forming for concrete

3. 38 x 140 x 4800 mm, joints at alternate posts, see 4

4. 9 mm plywood back-up plate at butt joints of bunk rails

5. 1 1/2 diam. galv. pipe, 1050 mm long animal side, 600 mm long wagon side; space 2400 mm oc with end posts 75 mm from end of bulk

6. M8 U-bolts (cut flush after tightening nuts)

7. add 38 x 89 mm for ewes and rams, relocate to upper position to maintain 200 mm opening for lambs

8. 200 mm, or adjust to suit

9. min. slope 1:25, width of slope equal or greater than tractor scraper

10. min. 50 mm concrete cover to reinforcing

11. 15M rebars, 450 mm long (shop weld to pipe posts before installation)

12. 15M rebars (wired to cross reinforcing 11)

13. 38 x 184 mm form planking

14. ALL DIMENSIONS IN THIS METRIC PLAN ARE IN MILLI METRES (mm) UNLESS OTHERWISE SPECIFIED