

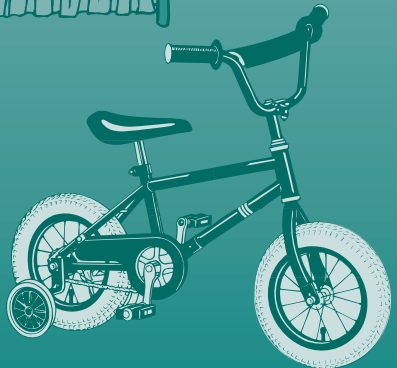

Health  
Canada

Santé  
Canada

# Information to Dealers of Second-Hand Children's Products



Canada

Our mission is to help the people of Canada  
maintain and improve their health.

*Health Canada*

Published by authority of the Minister of Health

Également disponible en français sous le titre  
*Information destinée aux vendeurs d'articles usagés  
pour enfants*

This publication can be made available (in/on computer  
diskette/large print/audio-cassette/braille) upon request.

© Her Majesty the Queen in Right of Canada, 2003

Cat. No. H46-2/03-299

ISBN H46-2/03-299

---

# Information to Dealers of Second-Hand Children's Products

---

Dealers are reminded of their responsibility under the *Hazardous Products Act* with respect to the safety of children's products. The *Hazardous Products Act* is a federal statute administered by Consumer Product Safety of Health Canada.

The *Hazardous Products Act* and Regulations do not distinguish between new and used products. Any person who sells, distributes, or gives away products not complying with this legislation is breaking the law in Canada. By selling an item that poses a hazard, a person could also be liable in a civil court of law.

Product Safety Officers monitor second-hand retail stores and flea markets for unsafe or non-compliant products and take enforcement action as required. This action could involve removing the products from sale and even prosecution.

**Products may not be safe and may not comply with the law because:**

- 1. They are too old to comply with current standards.**
- 2. They have been subject to a recall.**
- 3. Parts are missing, broken or labels and instructions are missing.**

The following is a partial list of products **currently regulated** under the Act. It is against the law to sell them if the legal requirements are not met:

- *Cribs and Cradles*
- *Car Seats*
- *Playpens*
- *Baby Gates*
- *Carriages and Strollers*
- *Children's Sleepwear*
- *Lawn Darts*
- *Toys and Toy Boxes*
- *Hockey Helmets and Face Protectors*

Not all products are regulated. The following is a list of some of the **non-regulated** products which could pose a hazard to children:

- *Baby Walkers*
- *Bunk Beds*
- *Children's Clothing with drawstrings*

**To ensure that you only handle safe products:**

- 1. Be well informed. Know the standards for products that are regulated.**
- 2. Routinely verify all possible sources to know about recalled products (see page 3).**
- 3. Ensure all parts are present, in good repair and functioning properly.**
- 4. Make sure assembly and/or use instructions are provided.**

- 5. If you are unsure whether a product is safe or whether it complies with the legislation, don't sell it, and don't give it away. Destroy it and then throw it away.**
- 6. Contact Consumer Product Safety for more information.**

See the contact list at the end of this document.

## **Associated Acts and Regulations**

A copy of the *Hazardous Products Act* and Regulations can be viewed at: <http://laws.justice.gc.ca/en/H-3/index.html>

## **Information on Product Recalls**

Canadian Juvenile Consumer Product Recalls:

[http://www.hc-sc.gc.ca/ehp/ehd/psb/juvenile\\_product\\_recalls.htm](http://www.hc-sc.gc.ca/ehp/ehd/psb/juvenile_product_recalls.htm)

Canadian Car Seat Recalls are posted by Transport Canada:

[http://www.tc.gc.ca/roadsafety/childsaf/notiavis/en/chart\\_e.htm](http://www.tc.gc.ca/roadsafety/childsaf/notiavis/en/chart_e.htm)

Recalls from United States on consumer products from the Consumer Product Safety Commission (CPSC) are available on:

<http://www.cpsc.gov/cpsc/pub/prerel/category/topic.html>

## Check List

*The information in this booklet has been prepared to provide an overview of the legislation dealing with children's products. It is not intended to substitute for, supersede or limit the requirements under the legislation. In case of any discrepancy between this summary and the legislation, the legislation will supersede the summary. Where questions of compliance arise, the regulations take precedent. In order for the product to comply, **all** conditions must be met.*

## Cribs

Cribs manufactured prior to September 1986 do not comply with current standards and should not be sold or used. These cribs expose the baby to serious potential hazards that may result in serious injuries, including death.

- The mattress support system must be solidly affixed to the frame of the crib. The height of the mattress support should not be adjustable without the aid of tools. (No S or Z shape hooks allowed!).
- A label containing the following information must be permanently affixed to the crib:
  1. Name and place of business of manufacturer/importer;
  2. Model name or number;
  3. Date of manufacture;

4. Warning statement about the strict adherence to assembly instructions, size of mattress and proper use of product.

- Assembly instructions and parts list must be either permanently printed on the product or included in a pouch attached to the crib.

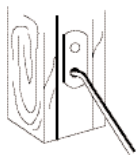

- Gap between the slats must not be more than 6 cm (2 3/8 in). Slats should not be loose or turn when twisted.

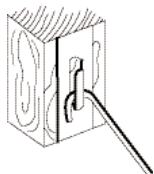

- The mattress supplied with the crib must be no thicker than 15 cm (6 in) and must fit snugly (no more than a 3 cm (1 3/16 in) gap on any side when the mattress is pushed into one of the corners of the crib).

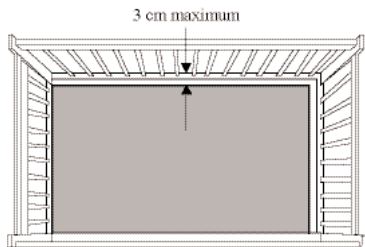

- The crib must be well maintained, i.e. no broken, cracked or missing parts, wood should be smooth and free of splinters, the metal should be free of burrs and sharp edges and there should be no loose bolts, nuts or slats.
- The crib should not have corner posts which extend more than 3 mm (1/8 in) above the highest side.

## Cradles

- A label (refer to cribs) must be permanently affixed.
- Must not rock or swing beyond a 20° angle from the vertical.
- Gap between the slats must not be more than 6 cm (2 3/8 in).
- Mattress supplied with cradle must not be 3 cm (1 3/16 in) shorter or narrower than interior dimensions of cradle or thicker than 8 cm (3 1/8 in).
- Must be well maintained (refer to cribs).

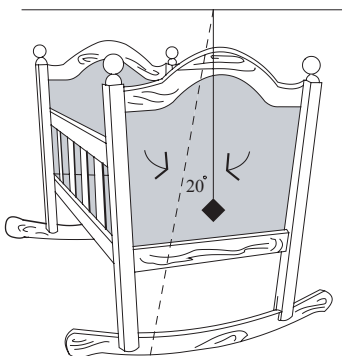

## Forward-facing and Rear-facing Car Seats and Booster seats

- A label containing the following information must be permanently affixed to the product:
  1. Name and address of manufacturer;
  2. Model name or number;
  3. Date of manufacture;



4. Indication product meets applicable Canadian Motor Vehicle Safety Standard (CMVSS) No. 213, 213.1, 213.2, 213.3, or 213.5;

5. Indicating proper use.

- Forward-facing car seats must have a tether strap.

- Instructions for proper installation and use must be available.

- All car seats must have a functional restraint system (harness system).

- Product must be in good repair, i.e. no cracks in plastic, missing hardware or loose parts.

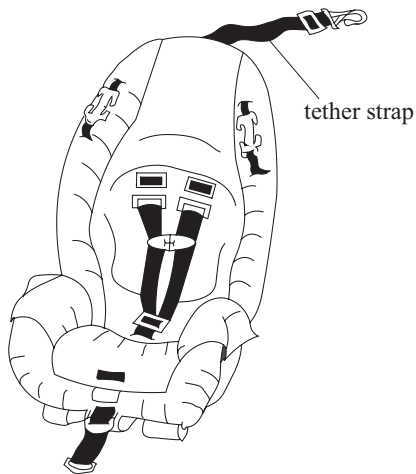

Note: car seats should not be sold if they are past the life span as recommended by the manufacturer.

For further information on car seats contact Transport Canada at **1-800-333-0371** or visit their Web site at: <http://www.tc.gc.ca/roadsafety/>.

# Baby Gates

- A label containing the following information is permanently affixed to the gate:
  1. Name and address of either the manufacturer, importer or distributor;
  2. Model name or number;
  3. Date of manufacture;
  4. Warning statement about intended use and installation.
- Openings in a gate should be small enough to prevent a child from placing their head through the holes.

- Any V shaped openings along the upper edge of the gate should have a spacing of 38 mm (1 1/2 in) or less.

- The vertical distance from the floor to the lowest point on the top surface of the gate must be 56 cm (22 in) or more.

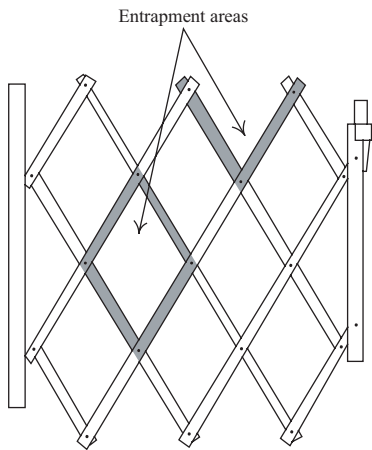

- Every exposed wooden metal or plastic part must be smoothly finished and free of splinters, burrs, cracks and other defects.

# Carriages and Strollers

- A label containing the following information must be permanently affixed to the product:
  1. Name and place of business of manufacturer or importer;
  2. Model name or number;
  3. Date of manufacture;
  4. Warning statements: to use the lap belt; not to leave child unattended; and, not to use the product for other purposes.
- Product must have a functioning braking device and, where the device acts on the tires, it must be self-adjusting to compensate for wear.
- Every stroller must have a lap belt attached to the frame or upholstery and a restraint to prevent the occupant from sliding downward.
- Products that fold must have a latching device which **engages automatically** and prevents the product from unintentionally folding.

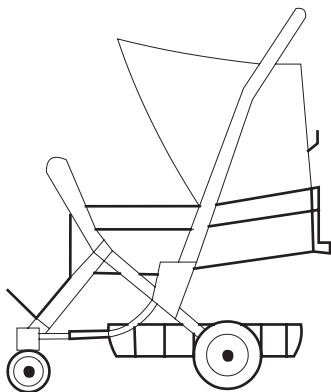

- Metal parts must be free of burrs and sharp edges.
- Cut tubing with ends accessible to the occupant must be protected by a cap which cannot be removed with a 9 kg (20 lb) force.
- Threaded end of bolts accessible to the occupant shall be protected by an acorn nut.
- Exposed wooden or plastic parts must be smoothly finished and free from splits, cracks or other defects.
- Product must be in good repair and have no loose parts which pose a choking hazard to a child.

## **Playpens**

- A label containing the following information must be permanently affixed to the product:
  1. Name and address of manufacturer;
  2. Model number;
  3. Date of manufacture;
  4. Statement: “This product complies with requirements of the Playpen Regulations (Canada)”.

- Should not present any scissoring, shearing or pinching hazards. The joint at the top drop rail must be covered by a plastic pad or designed to eliminate shearing or pinching hazards.

- Height of side from the floor to top of rail must be 48 cm (18.9 in) or more.

- Should not have more than 2 wheels or casters or provisions for their attachment.

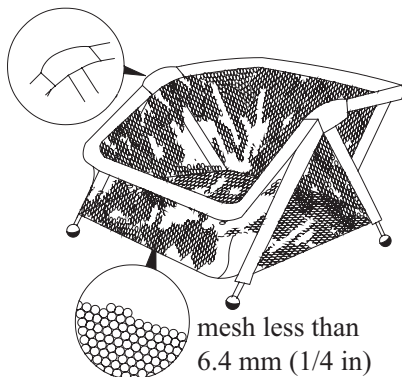

- Mesh in playpen will not permit the passage of a 6.4 mm (1/4 in) diameter rod (prevents finger or button entrapment).

- Playpen must be in good repair (refer to cribs).

- Cut metal tubing with ends accessible to occupant must be covered by a cap that cannot be removed with a 9 kg (20 lb) force.

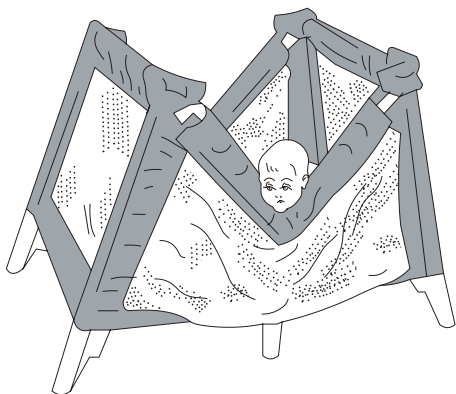

- No attached straps, cords, etc. more than 18 cm (7 in) in length.
- Threaded end of bolts accessible to the occupant must be covered with acorn nuts.

## Children's Clothing

### Sleepwear:

- Sizes up to 14X only except those designed for infants up to 7 kg.
- All loose fitting sleepwear including nightgowns, nightshirts, dressing gowns, bathrobes, house coats, robes, pyjamas and baby doll pyjamas made of 100% cotton, acrylic or acetate or blends of these fibres, **cannot** be sold due to their failure to meet flammability standards.
- These garments should be made of 100 % polyester, 100 % nylon or polyester/nylon blends to meet the flammability requirements.

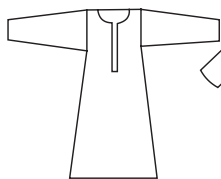

Night Gown

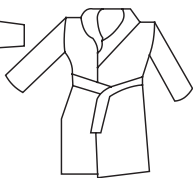

Dressing Gown

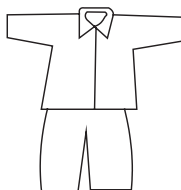

Loose Pajamas

## Drawstrings:

Drawstrings on children's snowsuits, jackets and sweatshirts can become caught on playground equipment, fences or other objects and result in strangulation, or in the case of a vehicle, the child being dragged. Check all children's clothing for loose drawstrings.

- All drawstrings should be removed from the head and neck area of children's clothing.
- At the bottom of children's clothing, either remove the drawstrings completely or trim the exposed length to 8 cm (3 in) with the garment fully stretched.
- Make sure the end of the drawstring is free of knots, loops or toggles, which can also become caught.

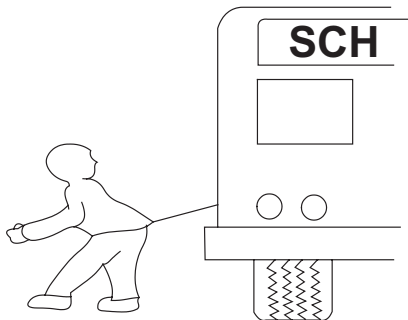
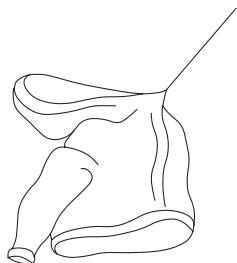

## Lawn Darts

- The sale of lawn darts with elongated tips have been illegal since January 1989.

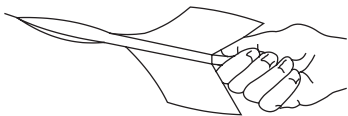

## Hockey Helmets

- Helmets more than 5 years old should not be bought or sold.
- Must have Canadian Standards Association (CSA) label indicating it meets the standards.
- Must have the date of manufacture.
- Must be in good repair, i.e. no cracks, missing padding or hardware or modifications such as drilled holes or stickers or paint.
- Must have a chin strap.

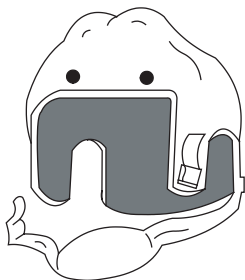

## Face Protectors for Ice Hockey and Lacrosse

- Must meet the CSA Standard.
- Must be in good repair, i.e. no cracks.



- Face protector must be attached to helmet or if sold separately, have hardware for proper installation and instructions on how to install.

## Toys

- Toys for children under three years of age must not have small parts that pose a choking hazard.
- Ensure that the toys are in good repair, i.e. no sharp edges, any wooden edges are smooth, and all fasteners such as nails, staples, bolts and screws are securely attached.
- Toys packaged in flexible film bags that have an opening of 35.6 cm (14 in) or larger, must be **labelled** with a suffocation warning.
- These bags must be made of a film that is at least 0.019 mm (0.75 mil) thick. Thin bags such as dry cleaning bags can be a suffocation hazard and cannot be used to package toys.

“PLASTIC BAGS CAN BE DANGEROUS. TO AVOID DANGER OF SUFFOCATION KEEP THIS BAG AWAY FROM BABIES AND CHILDREN.

LES SACS DE PLASTIQUE PEUVENT ÊTRE DANGEREUX. POUR ÉVITER LE DANGER DE SUFFOCATION, NE LAISSEZ PAS CE SAC À LA PORTÉE DES BÉBÉS NI DES ENFANTS.”

## Toy Boxes

- Toy boxes with lids are required to have holes in two or more adjacent sides to prevent the suffocation of a child who may become trapped inside.
- Toy boxes should also have lids that are lightweight and have good supporting hinges.



## Baby Walkers

Due to a number of serious injuries associated with baby walkers, it is not recommended that they be sold. The risk of serious injury to the baby is due to falls down stairs, as well as increased access to hot surfaces, hot drinks and electrical cords.

**BABY  
WALKERS  
BANNED  
APRIL 2004**

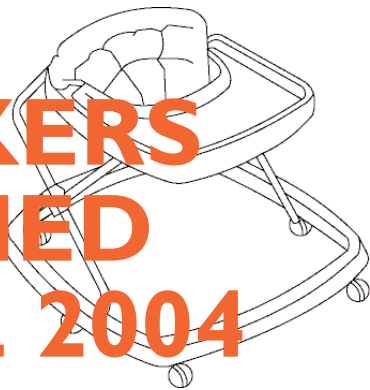

## Bunk Beds

Bunk beds can be dangerous!

Make sure that the top bunk has guard rails on all sides of the bed.

- Ensure that the ladder is in good repair and securely attached to the bed.
- Check to make sure that the frame of the bed is solid.
- Check the welds on metal bunk beds where the bed frame is fixed to the structure. Metal bunk beds with weld cracks should not be sold.
- Health Canada recommends that bunk beds meet the requirements of American standards (ASTM F-1427-96, and 16 CFR, Parts 1213, 1500 and 1513).

**For more information, contact the nearest  
Consumer Product Safety Regional Office  
listed below:**

Vancouver, British Columbia	(604) 666-5003 Bby_Prodsafe@hc-sc.gc.ca
Edmonton, Alberta	(780) 495-2626 Edm_Prodsafe@hc-sc.gc.ca
Calgary, Alberta	(403) 292-4677 Cal_Prodsafe@hc-sc.gc.ca
Saskatoon, Saskatchewan	(306) 975-4502 Sk_Prodsafe@hc-sc.gc.ca
Winnipeg, Manitoba	(204) 983-5490 Mb_Prodsafe@hc-sc.gc.ca
Hamilton, Ontario	(905) 572-2845 Tor_Prodsafe@hc-sc.gc.ca
Toronto, Ontario	(416) 973-4705 Tor_Prodsafe@hc-sc.gc.ca
Montreal, Quebec	(514) 283-5488 Quebec_Prod@hc-sc.gc.ca

Longueuil, Quebec	(450) 646-1353 Quebec_Prod@hc-sc.gc.ca
Quebec City, Quebec	(418) 648-4327 Quebec_Prod@hc-sc.gc.ca
Moncton, New Brunswick	(506) 851-6638 Atlantic_ProdSafe@hc-sc.gc.ca
Halifax, Nova Scotia	(902) 426-8300 Atlantic_ProdSafe@hc-sc.gc.ca
St. John's, Newfoundland	(709) 772-4050 Atlantic_ProdSafe@hc-sc.gc.ca

