

Appendix 1

Answers to the Activity Sheets

Activity Sheet 1 — Mysteries of Ancient Egypt

There is no right or wrong answer to these questions. Here are suggested answers.

1. Teams of 10 men pulled the blocks on wooden sleds. Wooden rockers (poles) may have been used to manoeuvre them into position.
2. Many of the ancient gods were depicted as animals or with human bodies and animal heads. The sphinx has a lion's body and a human head. The lion was one of the most powerful animals in ancient Egypt. The face of a pharaoh gave the sphinx the appearance of a powerful person. The sphinx may be a representation of the constellation Leo, which is associated with the sun god.
3. Tutankhamun died at the age of 17 or 18. The cause of his death appears to be an injury to the back of the head. This may have been caused by a fall, or he may have been struck by a blunt instrument. There is speculation that he was murdered.
4. The Egyptians mummified humans and many animals, birds and insects in order to ensure their life in the afterworld. By preserving the physical remains, they believed that the soul would return to the body and find sustenance to carry on life after death.

Activity Sheet 2 — Map of Ancient Egypt

See the map on page 16.

Activity Sheet 3 — Animals of Ancient Egypt

Names of animals that match the deities:

1. d; 2. c; 3. h; 4. g; 5. a; 6. f; 7. e; 8. b



Characteristics: A number of characteristics are possible for each animal. The scarab pushes a ball of dung, which is why the Egyptians chose it to represent the god that pushed the sun out of the eastern horizon at dawn.

Activity Sheet 4 — Plants of Ancient Egypt

Question 1: a. 4; b. 3; c. 2; d. 5; e. 5; f. 6; g. 2; h. 2; i. 1; j. 3

Question 2: 1. c; 2. e; 3. a; 4. h; 5. d; 6. f; 7. b; 8. g

Activity Sheet 5 — Characteristics of a Civilization

a. 7; b. 5; c. 6; d. 2; e. 8; f. 4; g. 1; h. 3

Activity Sheet 6 — Narmer's Palette

Side 1: a. 3; b. 8; c. 7; d. 9; e. 4; f. 5; g. 6; h. 2; i. 1

Side 2: a. 8; b. 1; c. 7; d. 3; e. 5; f. 6; g. 2; h. 4

Activity Sheet 7 — The Creation of the World

a. 2; b. 4; c. 1; d. 5; e. 3

Activity Sheet 8 — The Path of the Sun God

a. 4; b. 5; c. 8; d. 3; e. 2; f. 9; g. 11; h. 12; i. 6; j. 7; k. 10; l. 1

Activity Sheet 9 — The Sun God

a. 8; b. 10; c. 7; d. 11; e. 1; f. 9; g. 2; h. 12; i. 4; j. 6; k. 5; l. 3

Activity Sheet 10 — Cosmic and Earthly Deities

1. e; 2. f; 3. b; 4. i; 5. j; 6. g; 7. c; 8. a; 9. h; 10. d

Activity Sheet 11 — The Divine Family

1. e; 2. i; 3. b; 4. h; 5. g; 6. a; 7. c; 8. d; 9. f

Activity Sheet 12 — The Divine Family Tree

a. 4; b. 1; c. 6; d. 2; e. 7; f. 3; g. 5

Activity Sheet 13 — Deities and the Creatures that Represent Them

a. 11; b. 1; c. 3; d. 7; e. 9; f. 10; g. 2; h. 6; i. 12; j. 4; k. 8; l. 5

Activity Sheet 14 — The Symbolic Meaning of the Deities

a. 4; b. 3; c. 1; d. 5; e. 9; f. 6; g. 7; h. 8; i. 10; j. 2

Activity Sheet 15 — Pairs of Deities

1. c; 2. f; 3. a; 4. i; 5. g; 6. b; 7. e; 8. h; 9. d

Activity Sheet 16 — "Opening of the Mouth" Ceremony

Question 1: touch, smell, taste, hearing and sight

Question 2: a. 2; b. 10; c. 4; d. 5; e. 8; f. 1; g. 3; h. 7; i. 9; j. 6

Activity Sheet 17 — "Weighing of the Heart" Ceremony

Question 1: This is an open question with no right or wrong answer.

Question 2: a. 6; b. 2; c. 8; d. 1; e. 5; f. 3; g. 9; h. 4; i. 7; j. 10

Activity Sheet 18 — Identifying Royal Symbols

a. 9; b. 5; c. 8; d. 3; e. 4; f. 10; g. 7; h. 6; i. 2; j. 11; k. 12; l. 2; m. 3; n. 1; o. 4

Activity Sheet 19 — Fashion: Royal Women and Goddesses

a. 9; b. 1; c. 10; d. 6; e. 8; f. 4; g. 7; h. 14; i. 11; j. 12; k. 5; l. 3; m. 13; n. 2

Activity Sheet 20 — Fashion: Royal Men and Gods

a. 4; b. 3; c. 2; d. 1; e. 4; f. 3; g. 2; h. 5; i. 9; j. 7; k. 8; l. 2; m. 6; n. 11; o. 13; p. 1; q. 10; r. 14; s. 12

Note: The tail of war was worn by the pharaohs, and gods such as Horus and Thoth. It symbolizes divine authority and military might. It may represent the tail of a lion, an animal associated with the sphinx and the sun god.

Activity Sheet 21 — Headgear, Hairstyles and Make-up

Fig. 1 — a. 8; b. 4; name 3. Fig. 2 — a. 15; b. 2; name 4. Fig. 3 — a. 5; b. 6; c. 14; d. 3; e. 7; name 1. Fig. 4 — a. 1; b. 4; c. 11; name 2. Fig. 5 — a. 12; b. 13; c. 9; d. 14; name 5. Fig. 6 — a. 10; b. 14; name 6.

Activity Sheet 22 — Clothing and Personal Adornment

No right or wrong answer

Activity Sheet 23 — Drawing the Human Figure

Both figures — face in profile; eye from the front; shoulders from the front; torso in profile; arms, legs and feet in profile

Activity Sheet 24 — Drawing with a Grid

Number of squares needed to draw the woman:

1. lower leg = 6 squares
2. knees to waist = 6 squares
3. waist to shoulders = 4 squares
4. neck to top of head = 3 squares
5. width of shoulders = 5 squares
6. width of hips = 3 squares

Number of squares needed to draw the man:

1. lower leg = 6 squares
2. knees to waist = 6 squares
3. waist to shoulders = 4 squares
4. neck to top of head = 3 squares
5. width of shoulders = 6 squares
6. width of hips = 3 squares

Activity Sheet 25 — Pyramids

1. stone and metal hammers and chisels, wooden mallets, plumb lines (used to ensure that the blocks were set upright and not at an angle)
2. Suggested answers: as tombs to bury their pharaohs; to venerate the gods; to create a sacred landscape that mirrored the heavens (alignment of the pyramids with the heavens); to create a stairway to heaven
3. a. Step Pyramid; b. Bent Pyramid; c. Great Pyramid
4. a. 4; b. 2; c. 8; d. 3; e. 9; f. 6; g. 1; h. 7; i. 5

Activity Sheet 26 — Tutankhamun's Tomb

a. 7; b. 8; c. 3; d. 2; e. 9; f. 1; g. 4; h. 6; i. 5; j. 10

Activity Sheet 27 — Tutankhamun's Treasures

a. 4; b. 7; c. 6; d. 2; e. 10; f. 3; g. 9; h. 1; i. 8; j. 5

Activity Sheet 28 — Tutankhamun's Life and Death

1. He became pharaoh.
2. He died at the age of 17 or 18. He may have died from a blow to the back of the head or from a fall. Some experts think he was murdered. His body was mummified and placed in a tomb in the Valley of the Kings.

3. A — a. 5; b. 6; c. 3; d. 2; e. 8; f. 4; g. 11; h. 1; i. 13; j. 7; k. 12; l. 9; m. 10

B — a. 7; b. 3; c. 5; d. 4; e. 8; f. 2; g. 1; h. 6

Activity Sheet 29 — Men's Work

a. 6; b. 4; c. 1; d. 5; e. 7; f. 3; g. 8; h. 2

Activity Sheet 30 — Women's Work and Leisure

a. 2; b. 3; c. 8; d. 5; e. 4; f. 6; g. 1; h. 7

Activity Sheet 31 — Reading Hieroglyphs

1. Meaning of logograms — a. 4; b. 11; c. 2; d. 10; e. 6; f. 1; g. 8; h. 9; i. 3; j. 7; k. 12; l. 5

2. Sounds of phonograms — a. 4; b. 3; c. 7; d. 2; e. 5; f. 6; g. 8; h. 1

3. Determinatives — a. 2; b. 5; c. 3; d. 8; e. 7; f. 6; g. 4; h. 1

4. A: start upper right, finish lower left; B: start upper left, finish lower right; C: read from right to left; D: read from left to right

Activity Sheet 32 — Make Your Own Cartouche

Question 2: a. 14; b. 2; c. 4; d. 6; e. 12; f. 7; g. 3; h. 16; i. 12; j. 9; k. 4; l. 13; m. 17; n. 1; o. 8; p. 15; q. 11; r. 22; s. 18; t. 10; u. 5; v. 2; w. 5; x. 20; y. 19; z. 21

Activity Sheet 33 — Mathematics

Question 1: a. 12; b. 79; c. 368; d. 832; e. 1,690; f. 10,500; g. 200,123; h. 3,200,016

Question 2:

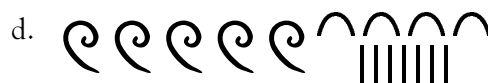
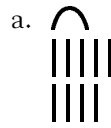



ACTIVITY SHEET 1

Mysteries of Ancient Egypt

What do you know about the mysteries of ancient Egypt?

1. How were the huge limestone blocks put in place during the construction of the pyramids? They fit so tightly together that there is virtually no space between them!



CMC ECD98-004 #2

2. Why do you think the sphinx has an animal body and a human face?



CMC ECD98-004 #9

3. What do you know about the mysterious death of the boy king Tutankhamun?

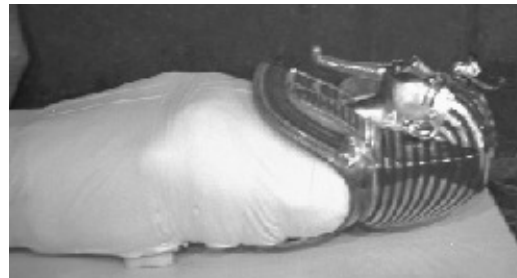

CMC ECD98-010 #26

4. Why do you think the Egyptians mummified people and animals?

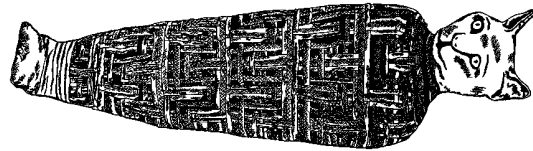

CMC S98 3511



ACTIVITY SHEET 2 Map of Ancient Egypt

Add the geographic features and the names of the principal cities, temples and pyramids to the map of Egypt.

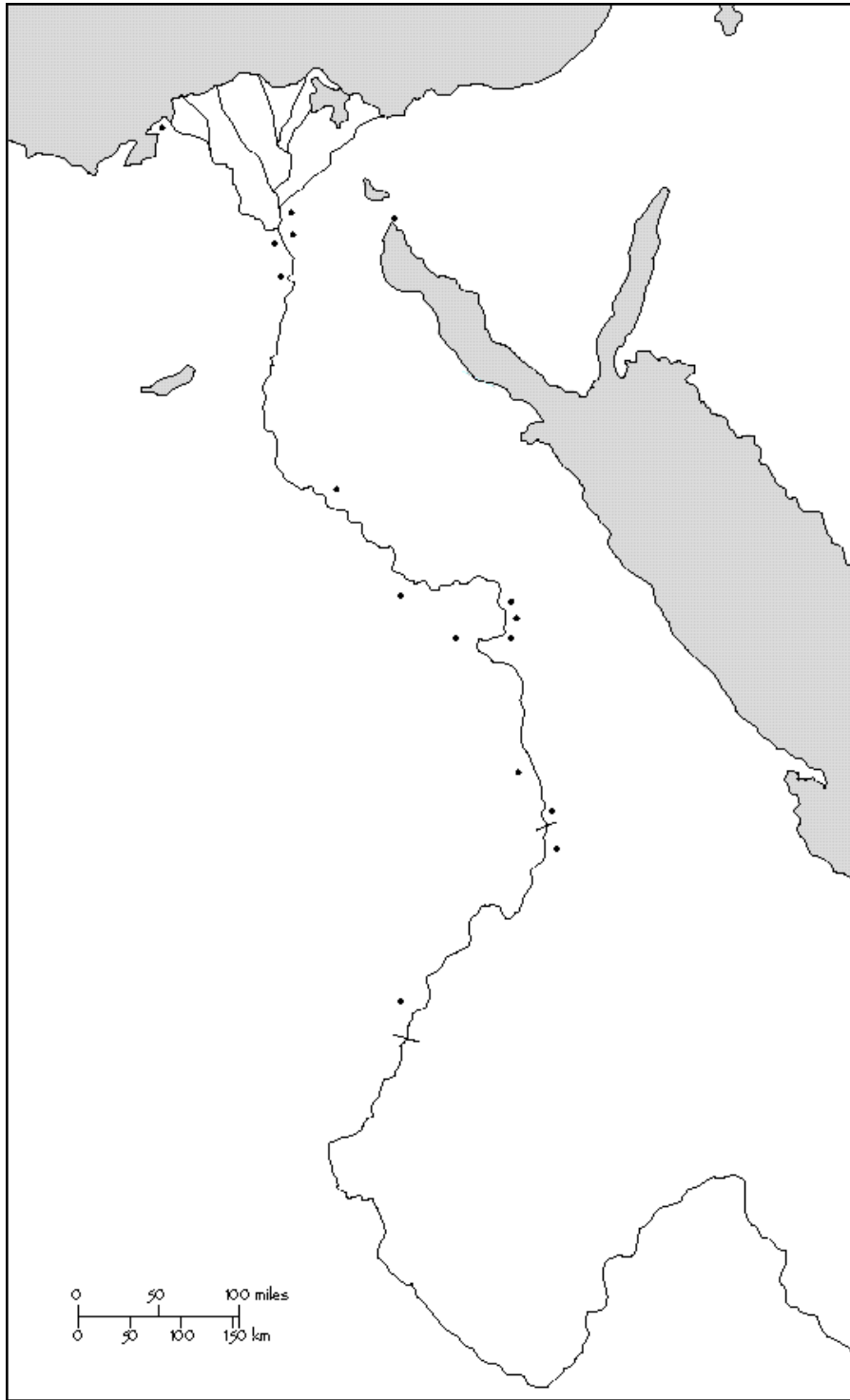

Clues









- Nile River
- Mediterranean Sea
- Alexandria (city)
- Giza (city)
- Memphis (city)
- Abydos (temple)
- Valley of the Kings (tombs)
- Edfu (temple)
- First Cataract
- Abu Simbel (temple)
- Lower Egypt
- Upper Egypt
- Nubia (country to the south)
- Western Desert
- Eastern Desert
- Red Sea
- Sinai Peninsula
- Suez (city)
- Heliopolis (city near Cairo)
- Tell el-Amarna (city)
- Thebes (city)
- Luxor and Karnak (temples)
- Aswan (city)
- Philae (temple)
- Second Cataract



ACTIVITY SHEET 3

Animals of Ancient Egypt

Many animals were used to represent the deities of ancient Egypt. Name the animals below and describe the characteristics that may explain why they were chosen to represent gods. You can make up your own characteristics or use the clues below.

Animal	Name	Characteristics
1. 		
2. 		
3. 		
4. 		
5. 		
6. 		
7. 		
8. 		

Clues

Animals: a. jackal; b. lion; c. crocodile; d. hippopotamus; e. falcon; f. scarab; g. scorpion; h. cobra

Characteristics: dangerous, fierce, hunter, swift, poisonous, pushes a ball of dung, fighter, sharp eyes, powerful, etc.



ACTIVITY SHEET 4 Plants of Ancient Egypt



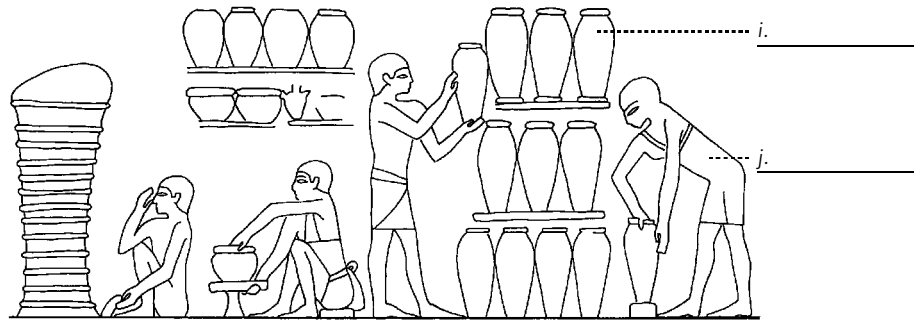
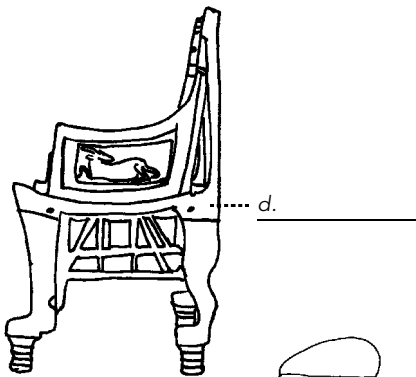
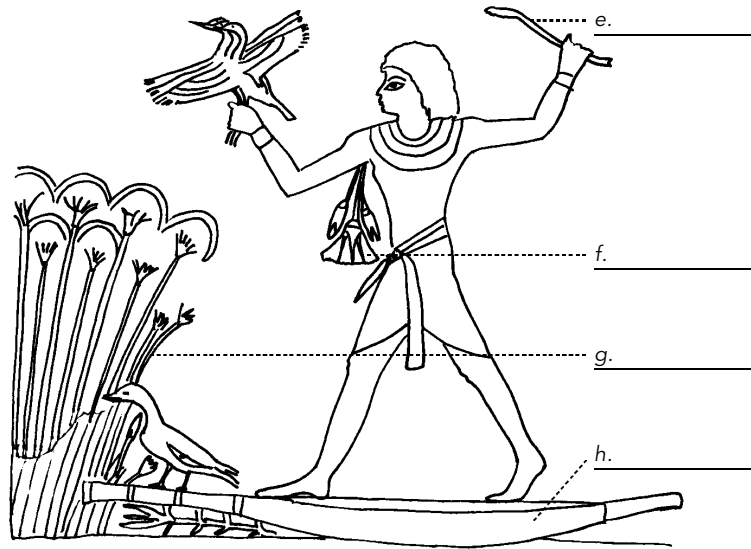
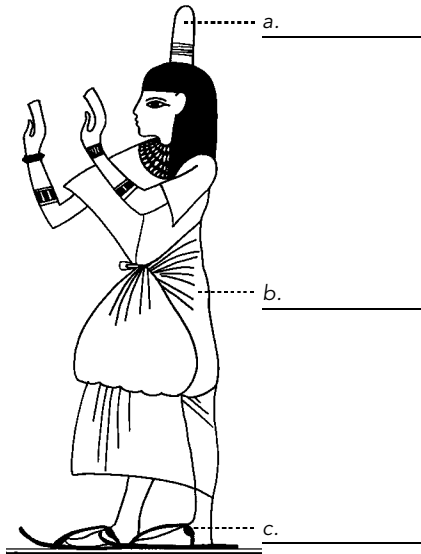





Plants and other materials were used to make things used in daily activities. Identify the plants shown, as well as the plant or material used to make the objects in the drawings. Next to each letter, write the number corresponding to the correct description.



Clues

- | | | |
|-------------|---|------------------|
| 1. Nile mud | 3. flax (linen) | 5. wood |
| 2. papyrus | 4. animal fats and perfume (water lilies) | 6. lotus flowers |

2. Match the drawings with the grains, vegetables and fruits that were eaten by the ancient Egyptians.

1.		a. wheat
1.		a. wheat
2.		b. lentils
3.		c. beans
4.		d. cucumbers
5.		e. figs and dates
6.		f. grapes
7.		g. pomegranates
8.		h. onions

3. Here is a recipe²⁰ for a type of cake enjoyed by the ancient Egyptians. Try it out to see how good it tastes!

Honey Date Cake

175 mL (3/4 c.) whole wheat flour

5 mL (1 tsp.) cinnamon

15 mL (1 tbsp.) cooking oil

125 mL (1/2 c.) honey

1 egg

50 mL (1/4 c.) pitted dates

Preheat oven to 200 °C (400 °F). Sift flour and cinnamon into a mixing bowl. In a small saucepan, heat oil and honey over very low heat. Stir until honey melts, watching carefully to prevent honey from burning. Remove from heat. Beat egg. Add honey mixture and egg to flour. Beat together. Chop dates and blend into mixture. Shape mixture into 6 or 8 cakes and place on greased baking sheet. Bake for 20 to 30 minutes.



ACTIVITY SHEET 5

Characteristics of a Civilization

The ancient Egyptians created one of the world's first great civilizations. Several characteristics must be present before a people or a nation can be considered a civilization. To prove that ancient Egypt was a civilization, next to each letter write the number corresponding to the characteristic.

a. _____

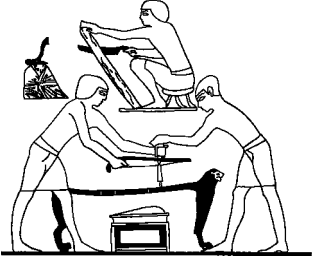

e. _____



b. _____

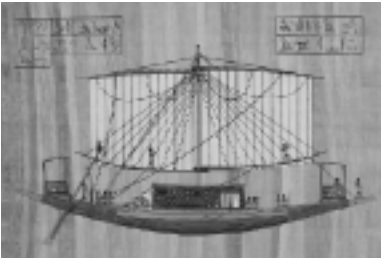

f. _____



c. _____

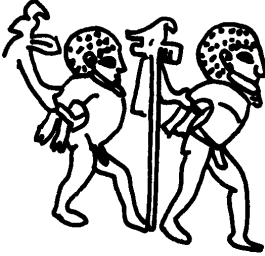

g. _____



d. _____



h. _____



Characteristics

- | | | |
|--|--------------------------------------|---|
| 1. religion | 4. communication (system of writing) | 7. high artistic achievement (artisans) |
| 2. leader and government | 5. trade (travel on the Nile) | 8. organized labour |
| 3. monumental architecture (large buildings) | 6. defence (warfare) | |



ACTIVITY SHEET 6

Narmer's Palette

The Narmer palette is the earliest artifact depicting an Egyptian king wearing the crowns of both Upper and Lower Egypt. It commemorates King Narmer's victory over Lower Egypt and the subsequent union of Upper and Lower Egypt in the late Pre-dynastic Period (3000 B.C.).

Label the drawings of the two sides of the palette. Next to each letter, write the number that corresponds to the description.

Side 1

1. mythical lions with elongated heads
2. a circular scoop for grinding make-up
3. King Narmer wearing the red crown of Lower Egypt
4. decapitated enemies on the battle-field
5. flag bearers
6. two men holding the lions on leashes
7. a scribe in front of the pharaoh
8. a sandal bearer behind the pharaoh
9. the pharaoh represented as a bull breaking down a town wall and trampling an enemy

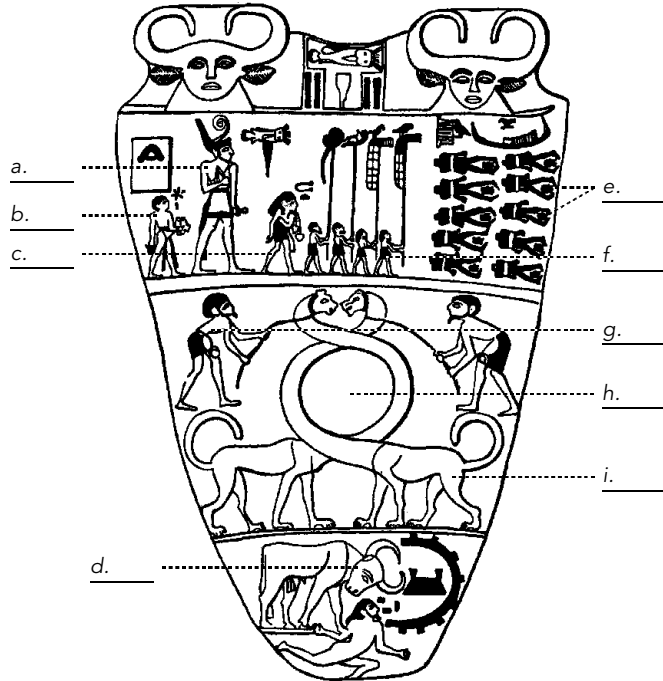

Side 2

1. King Narmer wearing the white crown of Upper Egypt
2. an enemy about to be struck with a mace
3. a *serekh* containing King Narmer's name (at top of palette)
4. two dead enemies
5. Horus (a falcon above the marshes)
6. a captive being led by the nose
7. a man carrying a jar
8. a cow's head with horns

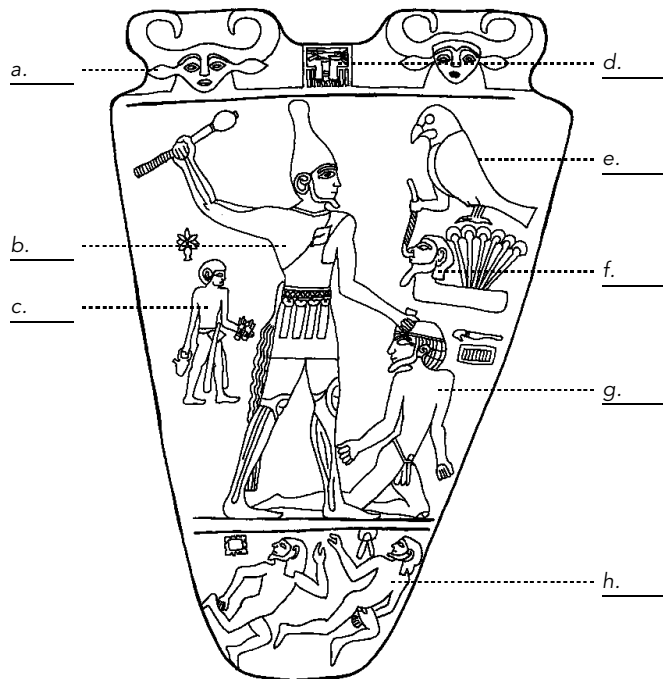



ACTIVITY SHEET 7 The Creation of the World

1. Label this drawing of Atum, the primeval god who created the cosmic gods of the universe. Next to each letter, write the number that corresponds to the description.

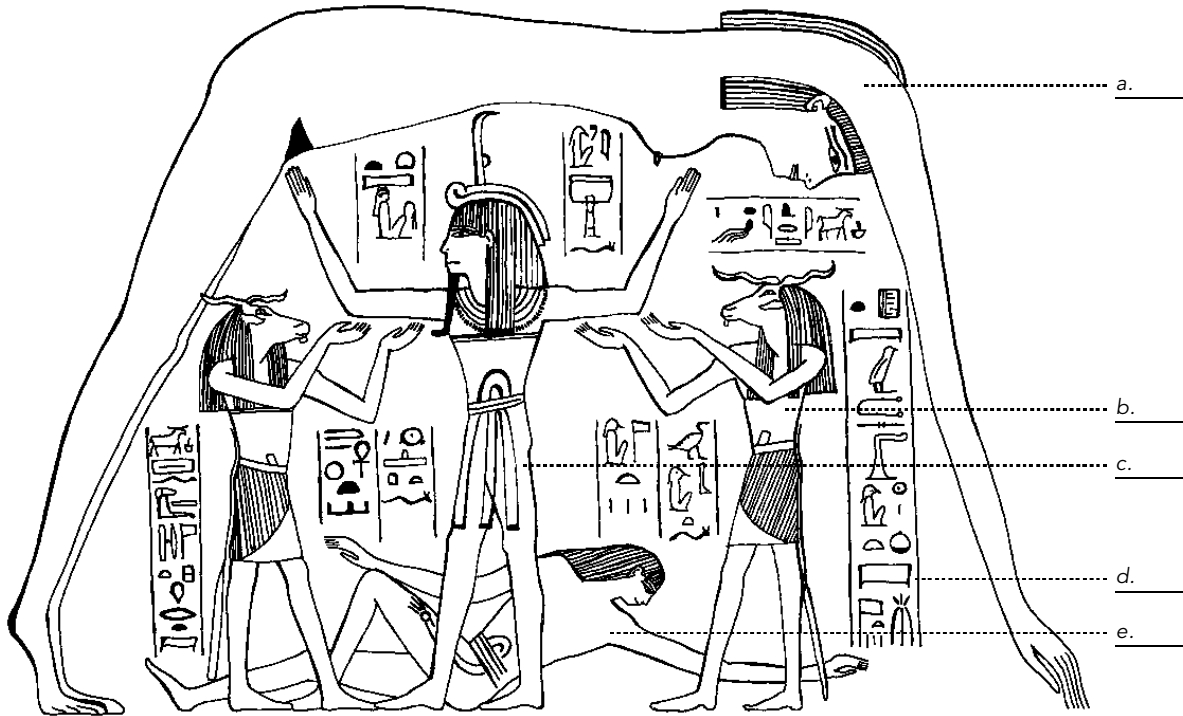

Clues

- | | | |
|-------------------------|------------------------------|-----------------------|
| 1. Shu, the god of air | 3. Geb, the earth god | 5. hieroglyphic texts |
| 2. Nut, the sky goddess | 4. Khnum, the ram-headed god | |

2. Make your own drawing of the creation of the world.



ACTIVITY SHEET 8 The Path of the Sun God

1. This drawing shows a scene taken from a wall painting in the tomb of the pharaoh Merenptah and Queen Tawosret (New Kingdom). Next to each letter, write the number that corresponds to the description. On another sheet of paper, make your own drawing of the path of the sun during the day and at night.

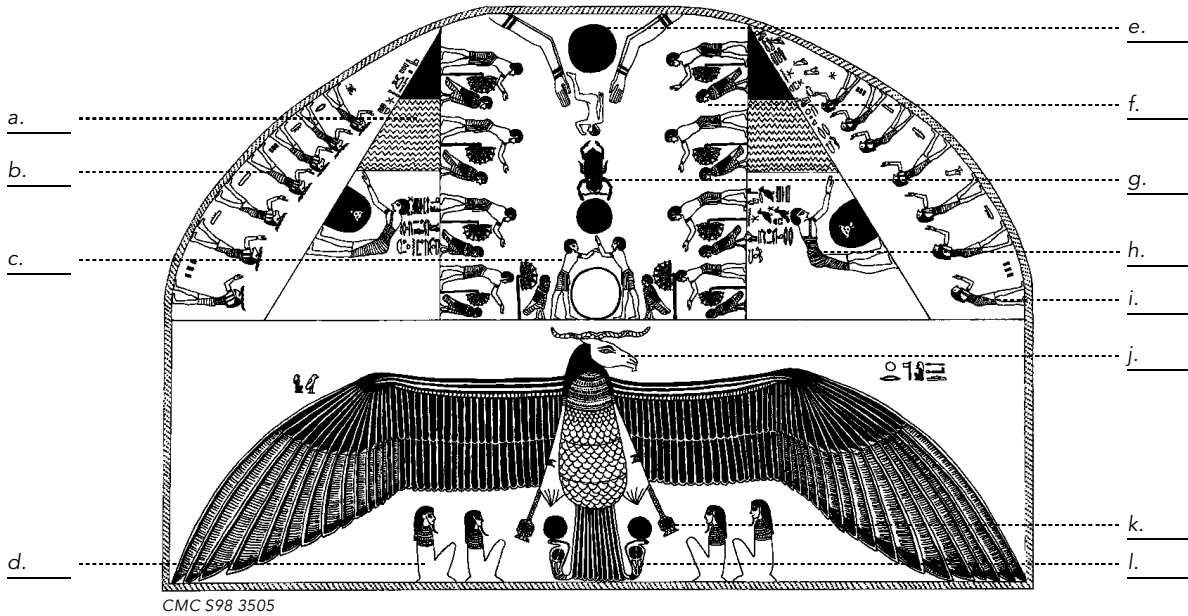

Clues

1. cobras wearing sun disks
2. sun disk
3. seated gods
4. band of water (represents the underworld)
5. ram-headed gods
6. falcon-headed gods
7. ram-headed falcon
8. man praising the sun god
9. *ba* bird (represents the soul)
10. *shen* rings (represent eternity)
11. sun god (scarab)
12. god bending over a mound



ACTIVITY SHEET 9 The Sun God

Label this drawing depicting the sun god in the form of a falcon. Next to each letter, write the number that corresponds to the description.

Clues



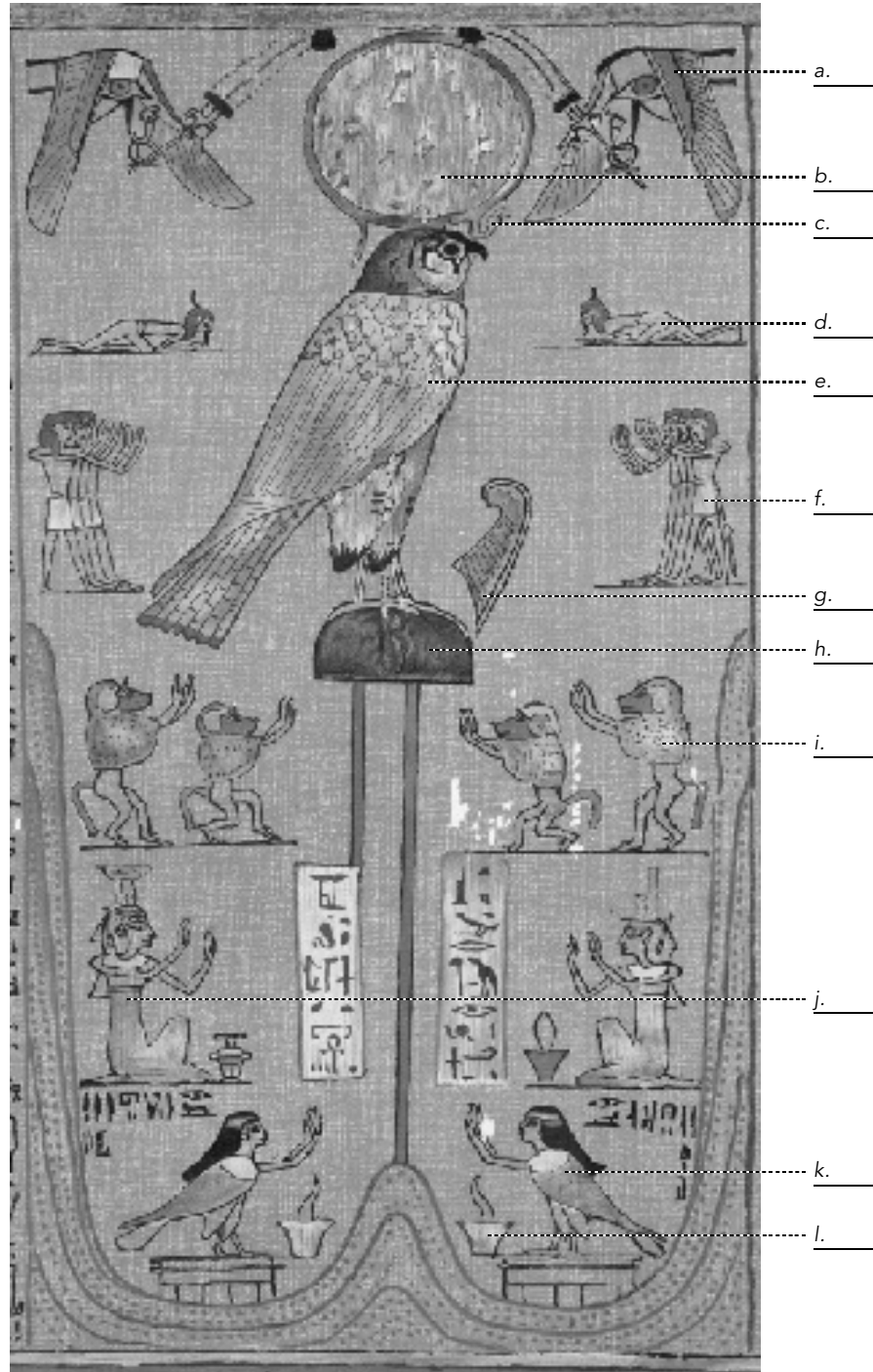







1. falcon
(represents the sun god)
2. feather
(represents justice)
3. burning incense
4. dancing baboons
(represent Thoth, god of wisdom and writing)
5. *ba* birds
(represent the soul of the deceased)
6. Isis and Nephthys
7. cobra
8. winged *wedjats*
(eyes of Re/Horus)
9. men praising the sun god
10. sun disk
11. worshippers on bended knees
12. hieroglyph for “west” and “death” (the falcon is standing on it)





ACTIVITY SHEET 10 Cosmic and Earthly Deities









Match the deities with what they are associated with.

Deities		What they are associated with
1. Atum		a. moon
2. Hapi		b. dry air
3. Shu		c. First Cataract of the Nile
4. Tefnut		d. protector of Lower Egypt
5. Geb		e. sun
6. Nut		f. Nile River
7. Khnum		g. sky
8. Khonsu		h. protector of Upper Egypt
9. Nekhbet		i. moist air
10. Wadjet		j. earth



ACTIVITY SHEET 11 The Divine Family

Match the deities with the role each played in the myth of the divine family.

Deities	Roles
1. Osiris 	a. Made her husband furious
2. Horus the child 	b. Fought a battle against his uncle
3. Horus (adult) 	c. Advised Isis to hide her son
4. Isis 	d. Was bitten by a snake
5. Seth 	e. Became Lord of the Dead
6. Nephthys 	f. Is the son of Nephthys and Osiris
7. Thoth 	g. Murdered his brother
8. Re 	h. Mummified her husband
9. Anubis 	i. Grew up in the marshes







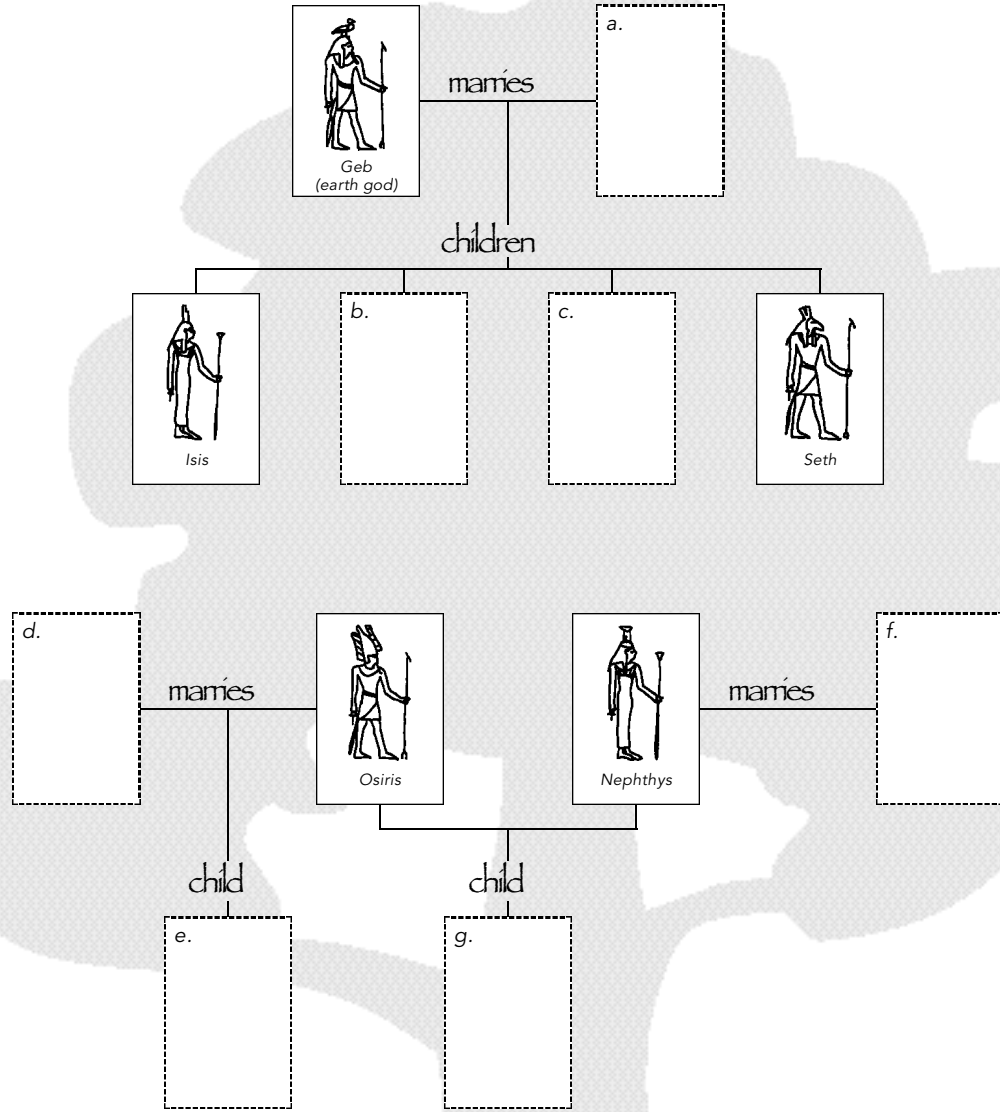

ACTIVITY SHEET 12

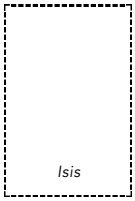
The Divine Family Tree

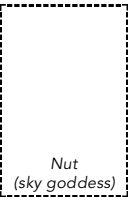
Cut out the drawings of the deities at the bottom of the page and paste them in their proper place on the family tree.

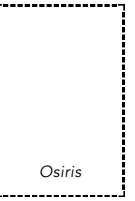













1.  Nephthys
2. 
3.  Seth
4.  Nut (sky goddess)
5.  Anubis
6.  Osiris
7.  Horus



ACTIVITY SHEET 13

Deities and the Creatures that Represent Them

Name the deities and the creatures that represent them.

Deities	
a. 	_____
b. 	_____
c. 	_____
d. 	_____
e. 	_____
f. 	_____
g. 	_____
h. 	_____
i. 	_____
j. 	_____
k. 	_____
l. 	_____

Clues











- | | | |
|----------------------|------------------------------------|----------------------------|
| 1. Sobek (crocodile) | 5. Bastet (cat) | 9. Anubis (jackal) |
| 2. Khnum (ram) | 6. Nekhbet (vulture) | 10. Sekhmet (lioness) |
| 3. Horus (falcon) | 7. Amemet (hippopotamus-crocodile) | 11. Thoth (ibis) |
| 4. Hathor (cow) | 8. Wadjet (cobra) | 12. Taweret (hippopotamus) |



ACTIVITY SHEET 14

The Symbolic Meaning of the Deities

Match the deities with their symbolic meaning. Create your own symbol with the same meaning.

Deities	Symbolic Meaning	Your Symbol
a. Atum 	_____	<input type="text"/>
b. Maat 	_____	<input type="text"/>
c. Neith 	_____	<input type="text"/>
d. Min 	_____	<input type="text"/>
e. Sekhmet 	_____	<input type="text"/>
f. Hapi 	_____	<input type="text"/>
g. Bastet 	_____	<input type="text"/>
h. Horus 	_____	<input type="text"/>
i. Hathor 	_____	<input type="text"/>
j. Wadjet 	_____	<input type="text"/>

Clues

- | | | | | |
|--------------|---------------------|-------------|---------------|--------------|
| 1. war | 2. royal protection | 3. justice | 4. creation | 5. fertility |
| 6. abundance | 7. motherhood | 8. kingship | 9. aggression | 10. music |



ACTIVITY SHEET 15

Pairs of Deities

Draw a line between these pairs of deities and their symbolic meaning.

Deities	Symbolic Meaning
1. Geb and Nut	a. protective and destructive female forces
2. Horus and Seth	b. pregnancy and childbirth
3. Bastet and Sekhmet	c. earth and sky
4. Isis and Nephthys	d. mummified men
5. Khnum and Atum	e. protectors of Upper and Lower Egypt
6. Sobek and Taweret	f. order and destruction
7. Nekhbet and Wadjet	g. creators of humans
8. Re and Khonsu	h. sun and moon
9. Osiris and Ptah	i. protectors of the dead



ACTIVITY SHEET 16 “Opening of the Mouth” Ceremony

The “opening of the mouth” ceremony was performed on mummified bodies or on coffins to restore the senses of the deceased. The ancient Egyptians believed that this ceremony made the deceased come alive in the afterworld.

1. What senses were restored to the deceased in the “opening of the mouth” ceremony?

2. Label the drawing of the “opening of the mouth” ceremony. Next to each letter, write the number that corresponds to the description.

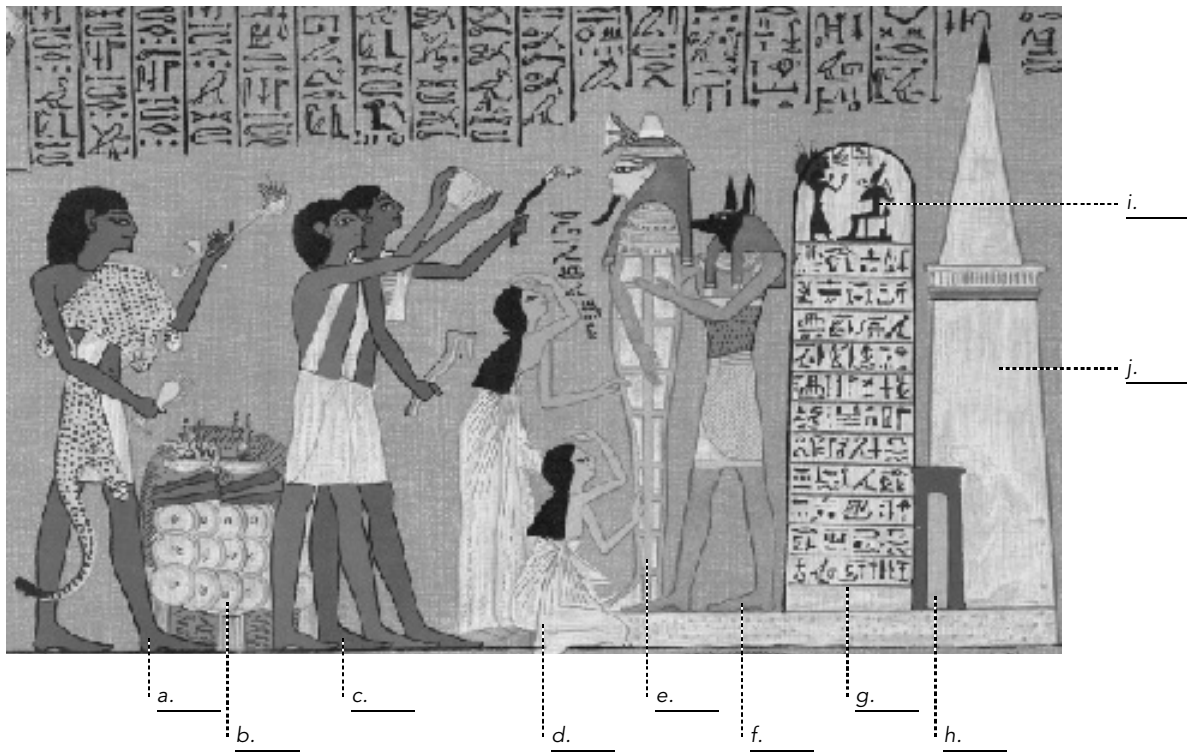

CMC S98 3573

Clues

- | | |
|---|---|
| 1. Anubis | 6. obelisk |
| 2. <i>sem</i> -priest holding an incense burner | 7. false door leading to the afterworld |
| 3. prayers for the dead | 8. the deceased |
| 4. priests holding tools for opening the mouth | 9. Osiris |
| 5. mourners | 10. offering table |



ACTIVITY SHEET 18

Identifying Royal Symbols

The royals were portrayed surrounded by symbols representing their station in life. The deities also used many of the same symbols.

Label the royal symbols in the drawings. Next to each one, write the number that corresponds to its description.



Pharaoh Ahmose makes an offering to his grandmother, Tetisheri

Clues

1. *ankh*
2. throne
3. sceptre
4. tail of war
5. uraeus (cobra)
6. lotus flower
7. vulture headdress
8. mace
9. white crown of Upper Egypt
10. *atef* (double-feather) crown
11. sun disk
12. *nemes* headcloth

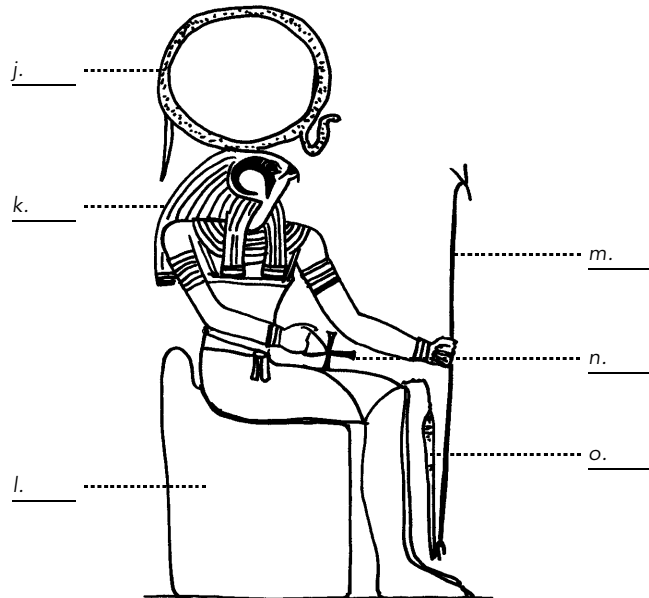

Re-Horakhty, one form of the sun god



ACTIVITY SHEET 19

Fashion: Royal Women and Goddesses

The clothing worn by elite women and goddesses illustrates the Egyptians' sense of fashion. Their hairstyles, jewellery and make-up contributed to their attractive appearance and reinforced their position in society.

Label the drawing. Next to each letter, write the number that corresponds to the description.

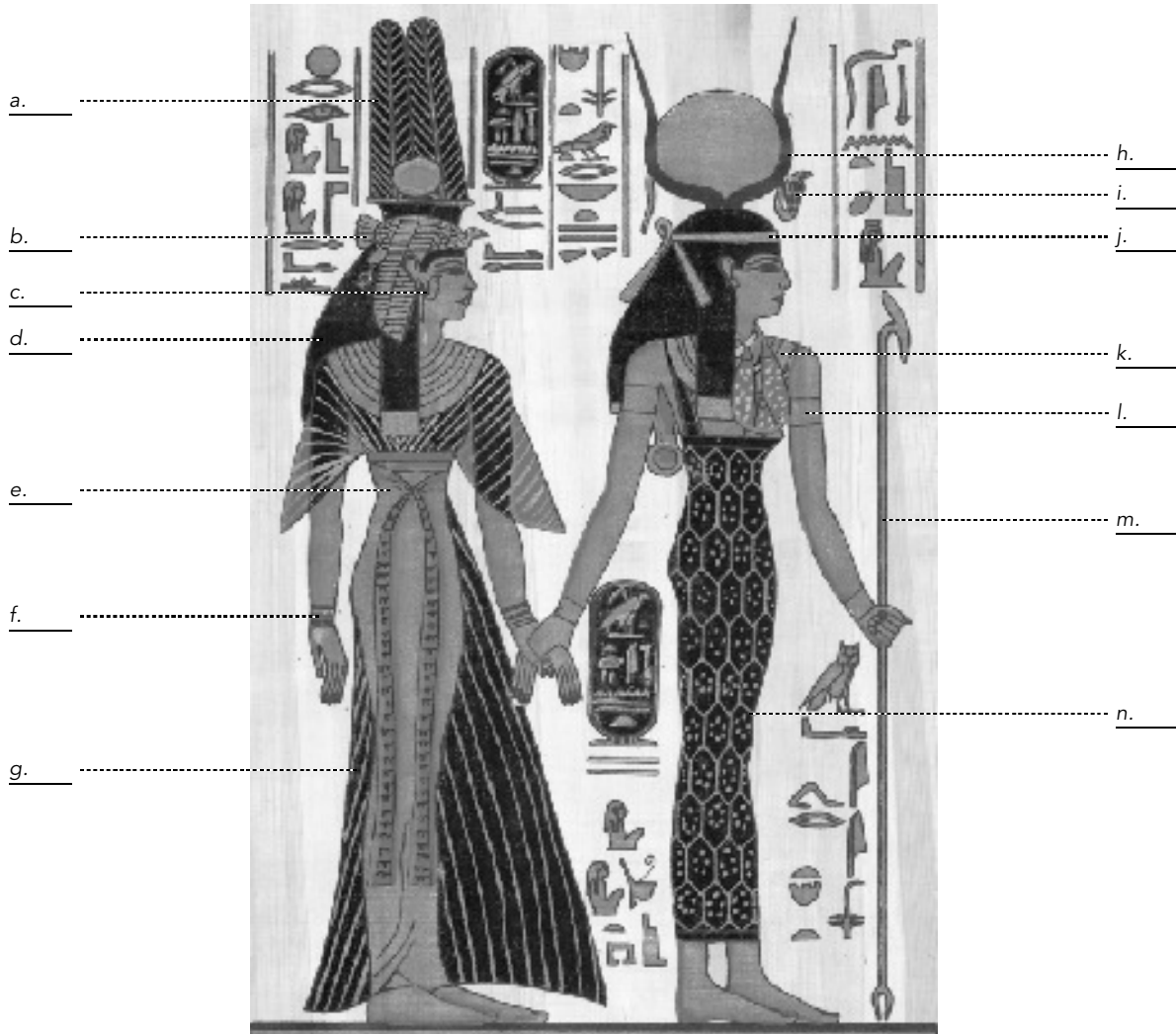

Queen Nefertari, the favourite wife of Ramses II, and the goddess Isis
CMC S98 3534

Clues

- | | | |
|----------------------|--------------------------------|-------------------------------------|
| 1. vulture headdress | 6. wig | 11. uraeus (cobra) |
| 2. sheath dress | 7. wraparound dress | 12. headband |
| 3. armband | 8. belt | 13. was sceptre |
| 4. bracelet | 9. atef (double-feather) crown | 14. cow horn and sun disk headdress |
| 5. necklace | 10. earrings | |



ACTIVITY SHEET 20

Fashion: Royal Men and Gods

The clothing worn by elite men and gods illustrates the Egyptians' sense of fashion. Their hairstyles, jewellery and make-up contributed to their attractive appearance and reinforced their position in society.

Label the drawings. Next to each letter, write the number that corresponds to the description.

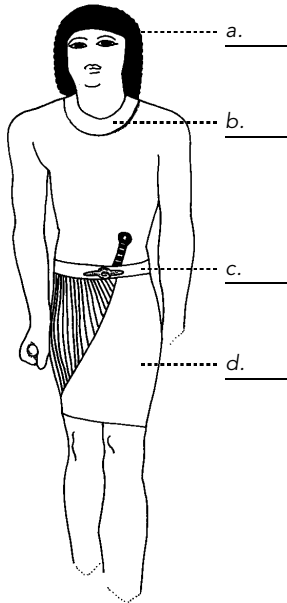

Nobleman
(Old Kingdom)

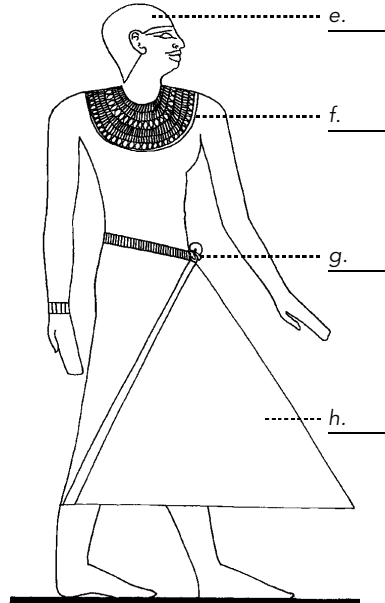

Official
(Middle Kingdom)



Pharaoh Seti I
(New Kingdom)

Clues

- | | |
|--|-----------------------------------|
| 1. short pleated kilt | 7. blue crown |
| 2. belt | 8. scarf |
| 3. necklace | 9. bracelet |
| 4. wig | 10. nemes headcloth |
| 5. mid-calf kilt with large apron (stiffened to maintain its triangular shape) | 11. beard |
| 6. long see-through kilt | 12. tail of war |
| | 13. armband |
| | 14. short pleated kilt with apron |

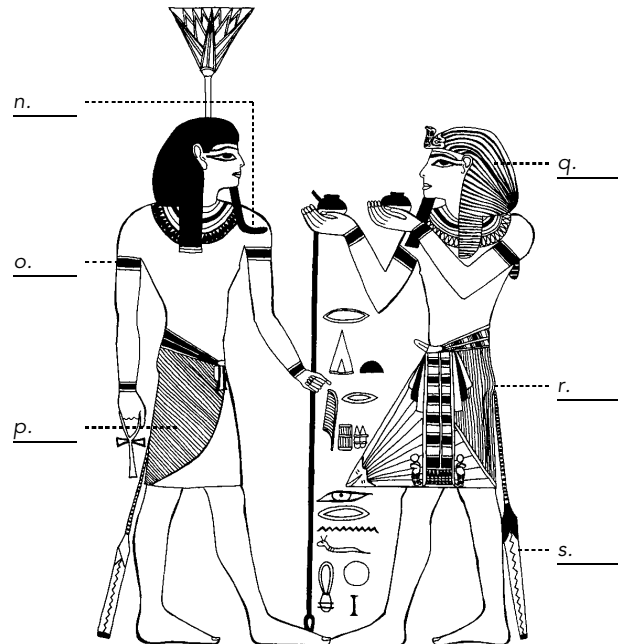

Pharaoh Ramses I (New Kingdom) and the god Nefertem
CMC S98 3509



ACTIVITY SHEET 21 Headgear, Hairstyles and Make-up

Royal men and women wore jewellery, make-up and various types of headgear. Label the drawings. Next to each letter, write the number that corresponds to the description. Write the number that corresponds to each person's name beside his or her picture.

Figure 1

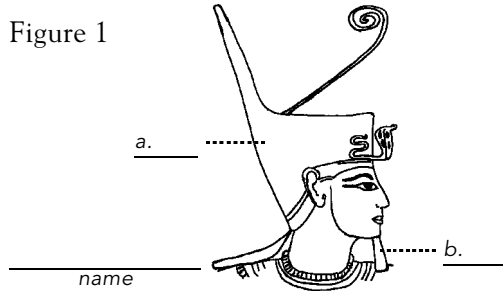

Figure 4

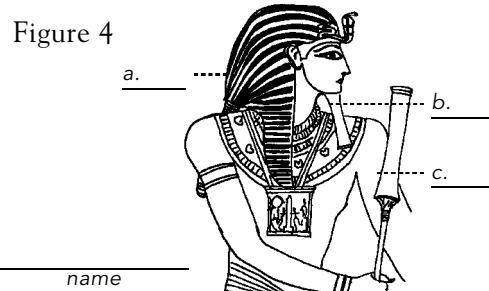

Figure 2

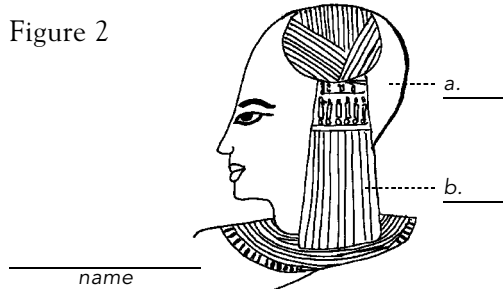

Figure 5

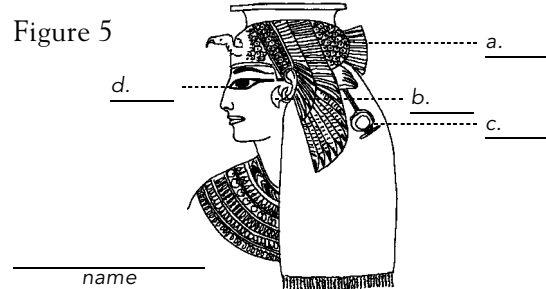

Figure 3

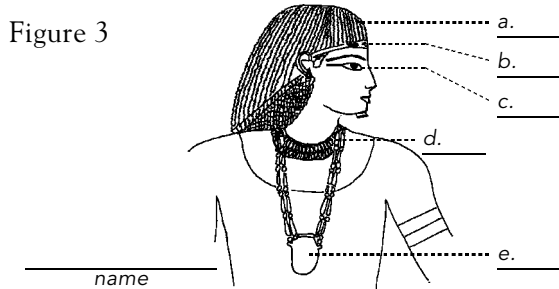
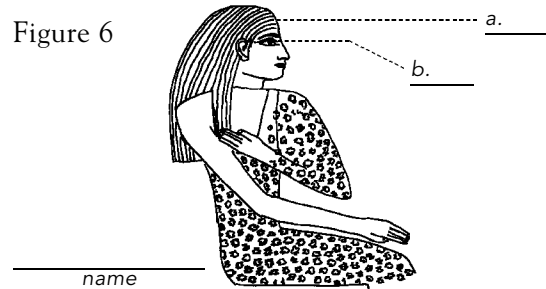

Figure 6



Clues

1. *nemes* headcloth
2. sidelock of youth
3. necklace
4. pharaoh's beard
5. two-tiered wig
6. headband
7. heart amulet
8. red crown of Lower Egypt
9. *shen* ring (symbol of eternity)
10. single-length wig
11. *sekhem* sceptre
12. vulture headdress
13. earrings
14. kohl
15. shaven head

The royals pictured here are:

1. Vizier Ramose:
"I am wearing my heart on my heart."
2. Pharaoh Seti I:
"I am holding a symbol of power."
3. Pharaoh Ramses III:
"I am wearing something to frighten you."
4. Prince Khaemuset:
"I am keeping cool."
5. Queen Nefertari:
"I feel like flying."
6. Princess Nefertiabet:
"You can spot me a mile away."



ACTIVITY SHEET 22 Clothing and Personal Adornment

Dress an Egyptian man and woman by adding clothing and jewellery (necklaces, bracelets, earrings, belt buckles, pendants, hair bands, perfumed cones).

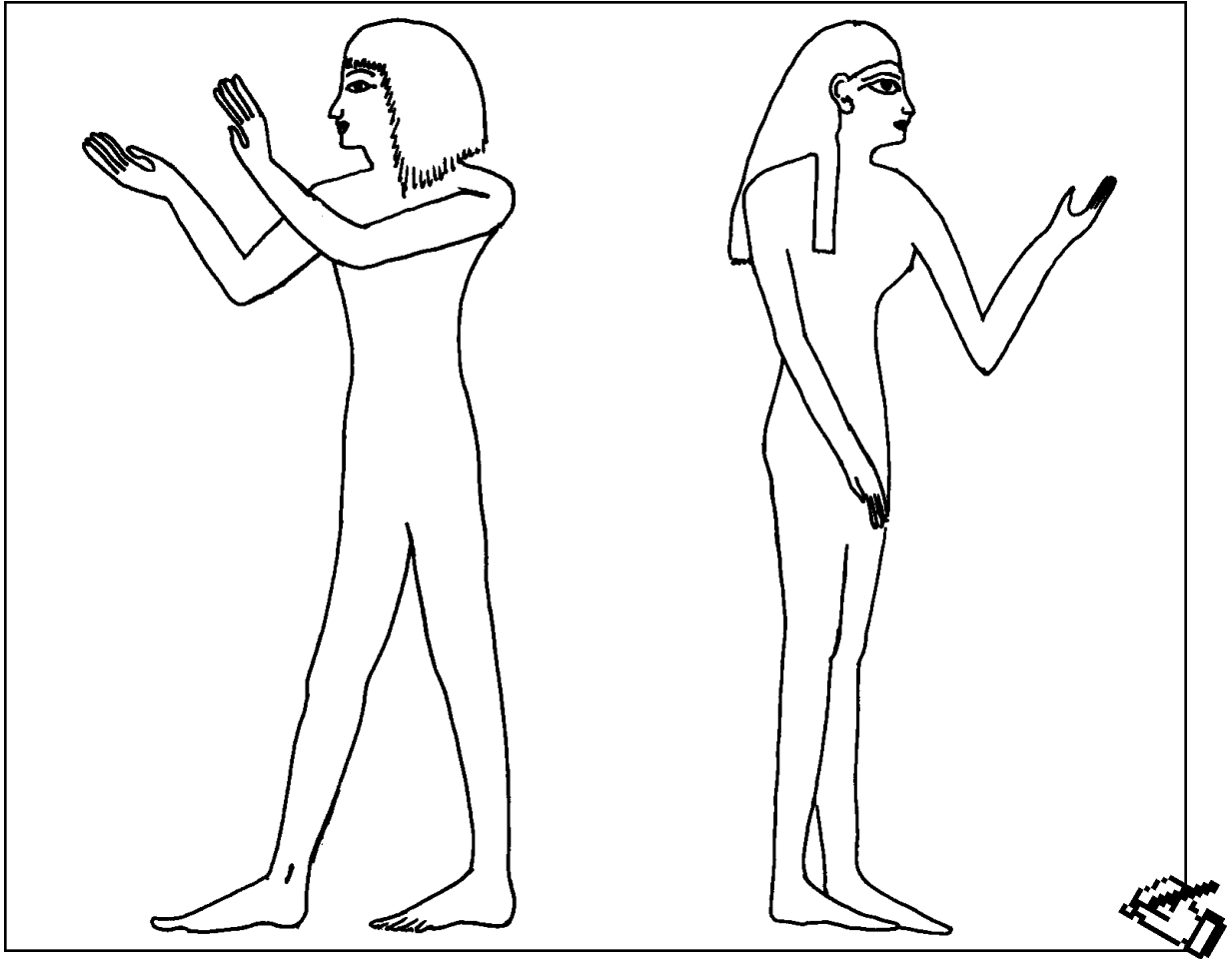

These drawings show styles of clothing that were popular among servants and the upper class in ancient Egypt. You can use them to help you dress the Egyptian man and woman.

Old Kingdom

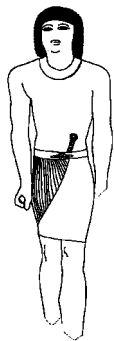

Nobleman



Female Servant

Middle Kingdom

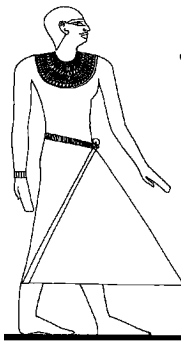

Official

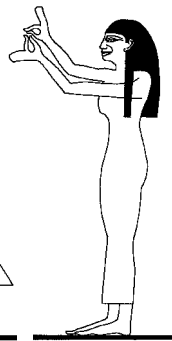

Female Servant

New Kingdom



Nobleman



Noblewoman



ACTIVITY SHEET 23 Drawing the Human Figure

Ancient Egyptian artists followed a formula that made figures look stiff. They sketched figures according to a predetermined pattern and made no attempt to show perspective. Label the drawings by indicating the perspective shown: a) in profile or b) from the front.

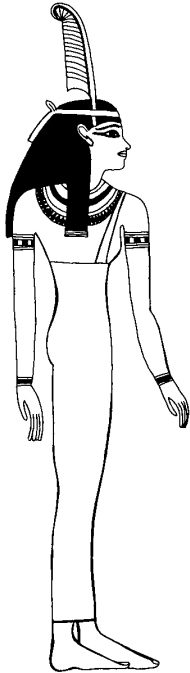

Maat, goddess of justice

1. eye _____
2. face _____
3. shoulders _____
4. arms _____
5. torso _____
6. legs and feet _____



Hunefer, a nobleman

1. eye _____
2. face _____
3. shoulders _____
4. arms _____
5. torso _____
6. legs and feet _____



ACTIVITY SHEET 24 Drawing with a Grid

Ancient Egyptian artists sketched figures according to a predetermined pattern, using an 18-square grid. Draw these two figures on the blank grid by following the pattern shown. Before beginning your drawing, count the squares that are needed for each part of the body.

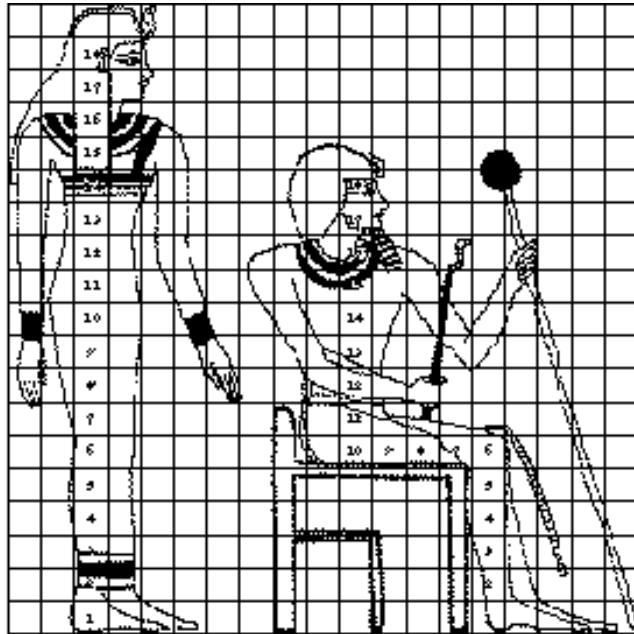

Number of squares needed to draw:

	woman	man
1. lower leg	=	___
2. knees to waist	=	___
3. waist to shoulders	=	___
4. neck to top of head	=	___
5. width of shoulders	=	___
6. width of hips	=	___

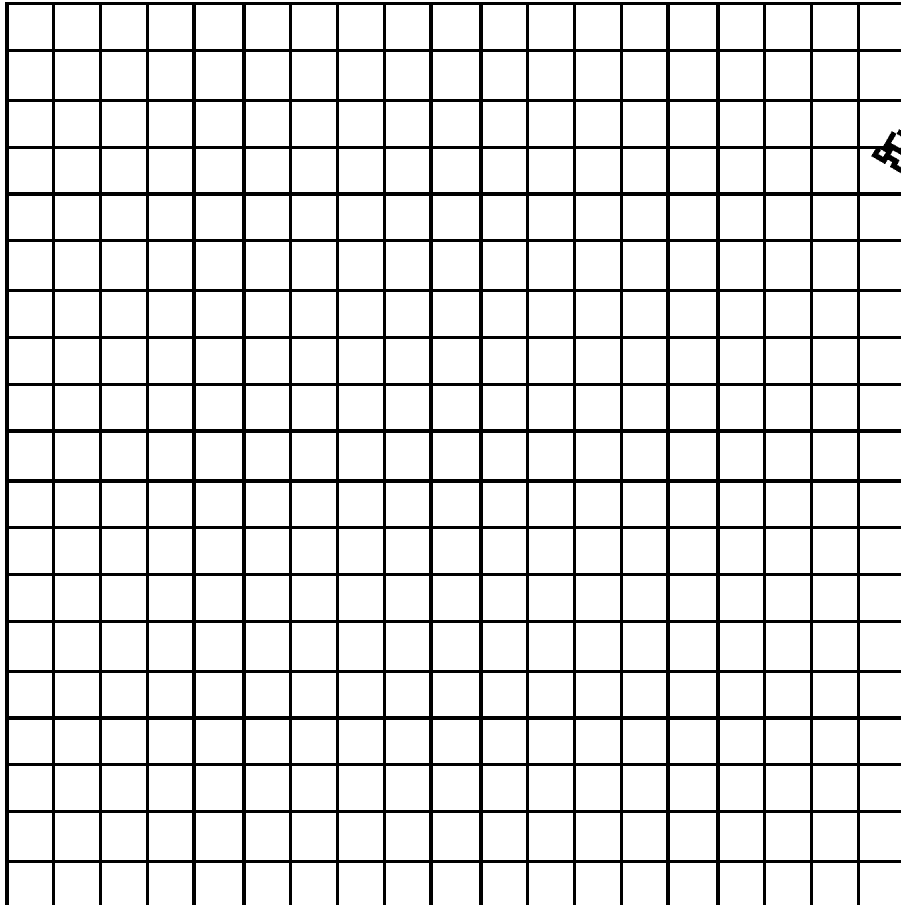



ACTIVITY SHEET 25 Pyramids

One of the oldest mysteries surrounding ancient Egypt concerns the building of the pyramids.

1. What kinds of tools do you think were used to cut the stone blocks for the pyramids?

2. Why do you think the ancient Egyptians built pyramids?

3. These three drawings show a progression in the building of pyramids, from the earliest style to the geometrically accurate pyramid. Write the name of each pyramid below its description.



CMC ECD98-025 #65

- a) This early pyramid was designed to look like a stairway to heaven. Its name begins with “s” and has four letters.



CMC ECD98-025 #61

- b) The upper part of this pyramid was bent to prevent the structure from collapsing. Its name begins with “b” and has four letters.



CMC ECD98-015 #100

- c) The biggest pyramid of all, its popular name begins with “g” and has five letters.



ACTIVITY SHEET 26 Tutankhamun's Tomb

1. Label the drawing of Tutankhamun's tomb. Next to each letter, write the number that corresponds to the description.

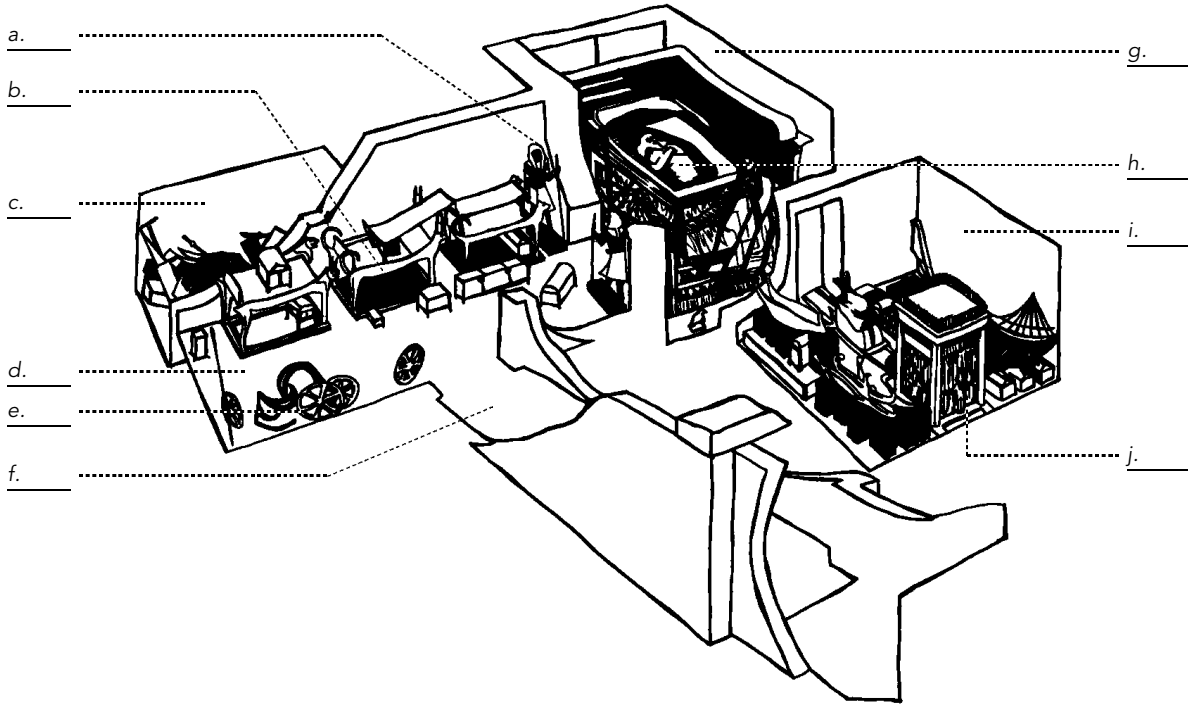

Clues

- | | | |
|-------------------------------|------------------------|---|
| 1. entrance passage | 4. burial chamber | 8. royal bed |
| 2. antechamber (largest room) | 5. treasury room | 9. chariot wheels |
| 3. annex (smallest room) | 6. Tutankhamun's mummy | 10. shrine (largest box in the treasury room) |
| | 7. sentinel figures | |

2. Pretend you are an Egyptian pharaoh or queen. What would you want to have put in your tomb for your afterlife?



ACTIVITY SHEET 27 Tutankhamun's Treasures

Pretend you are preparing an exhibit on Tutankhamun's treasures and other ancient Egyptian artifacts. Write labels for the treasures below. Your label should say what the object is and what it is made of, and include a bit of information on it.

a.



CMC S98 3497

a.

b.

c.

d.

e.

b.

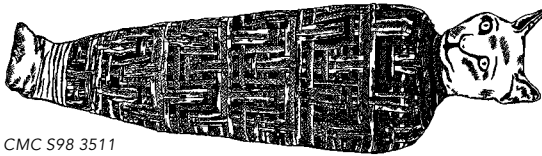

CMC S98 3511

c.

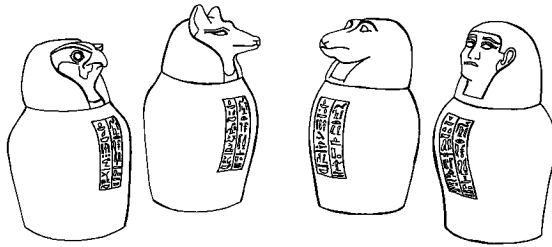

CMC S98 3516

e.

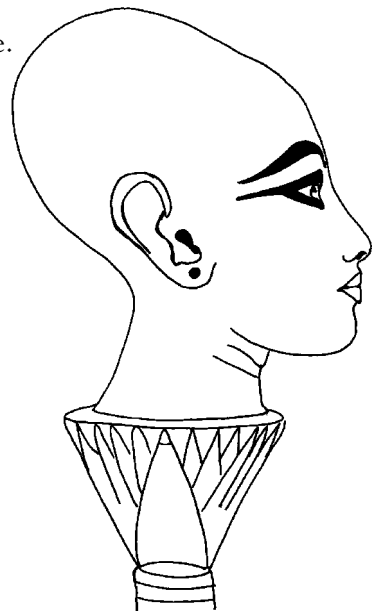

d.

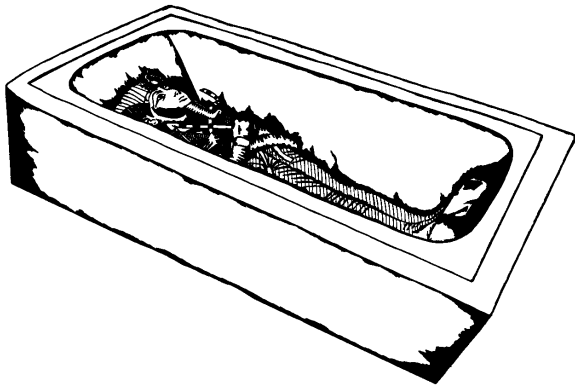

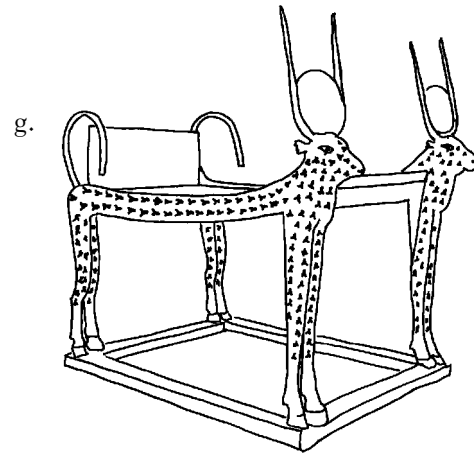
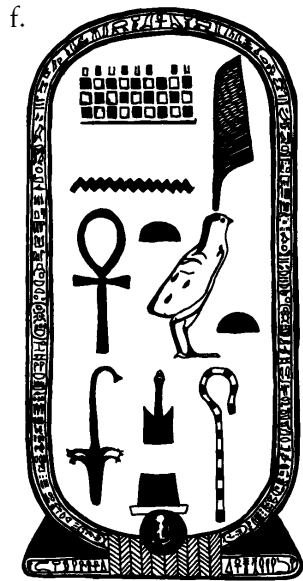

f. _____

g. _____

h. _____

i. _____

j. _____

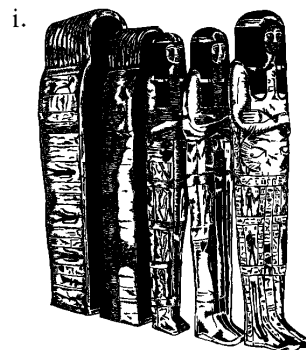

CMC S98 3510

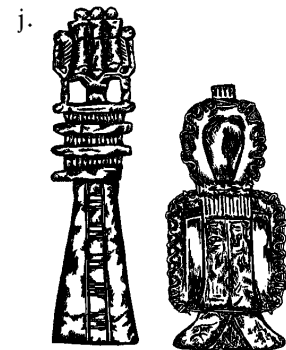

CMC S98 3514

Clues

1. Tutankhamun's gold mask	4. model boat	8. nesting coffins
2. Tutankhamun's mummy in a sarcophagus	5. amulets	9. royal bed
3. box with Tutankhamun's cartouche	6. canopic jars	10. bust of Tutankhamun
	7. cat mummy	



ACTIVITY SHEET 28 Tutankhamun's Life and Death

There are many mysteries surrounding the life and death of Tutankhamun.

1. What important event happened when he was 9 years old?

2. What do you know about his death?

3. These paintings from Tutankhamun's tomb tell us about his life and his journey to the afterworld. Next to each letter, write the number that corresponds to the description. Then write a sentence describing what is happening in the painting.

A. Tutankhamun and his wife Ankhesenamun hunting birds

CMC 598 3529

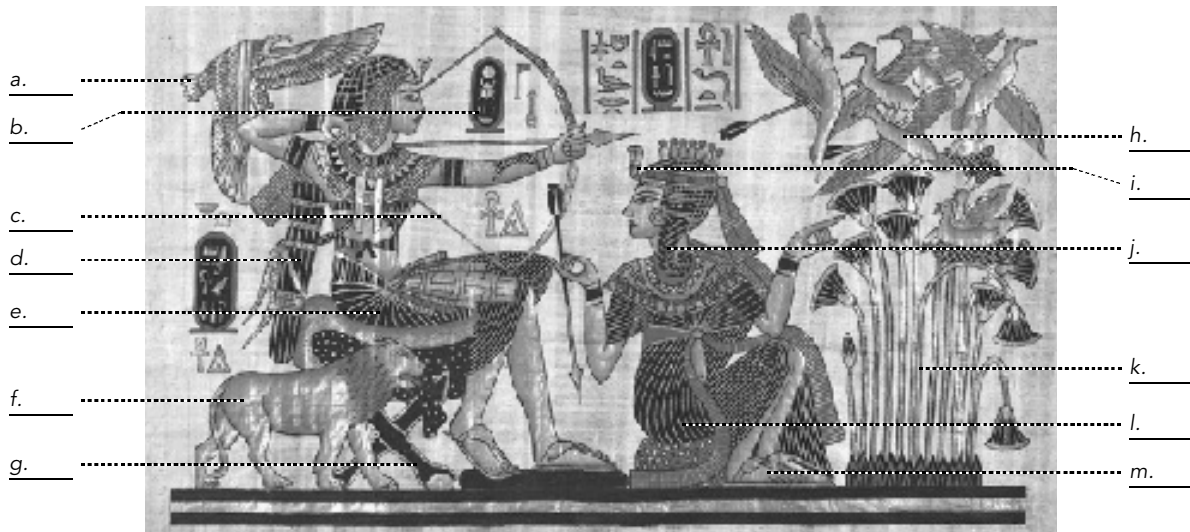

Clues

- | | | | |
|------------------|----------------------------|---------------------|------------------------|
| 1. birds | 5. vulture | 8. kilt | 11. folding stool |
| 2. quiver | 6. Tutankhamun's cartouche | 9. wraparound dress | 12. papyrus thicket |
| 3. bow and arrow | 7. sidelock of youth | 10. sandals | 13. double-cobra crown |
| 4. lion | | | |

B. Tutankhamun and Ay (his successor), who is performing the “opening of the mouth” ceremony

CMC 598.3522

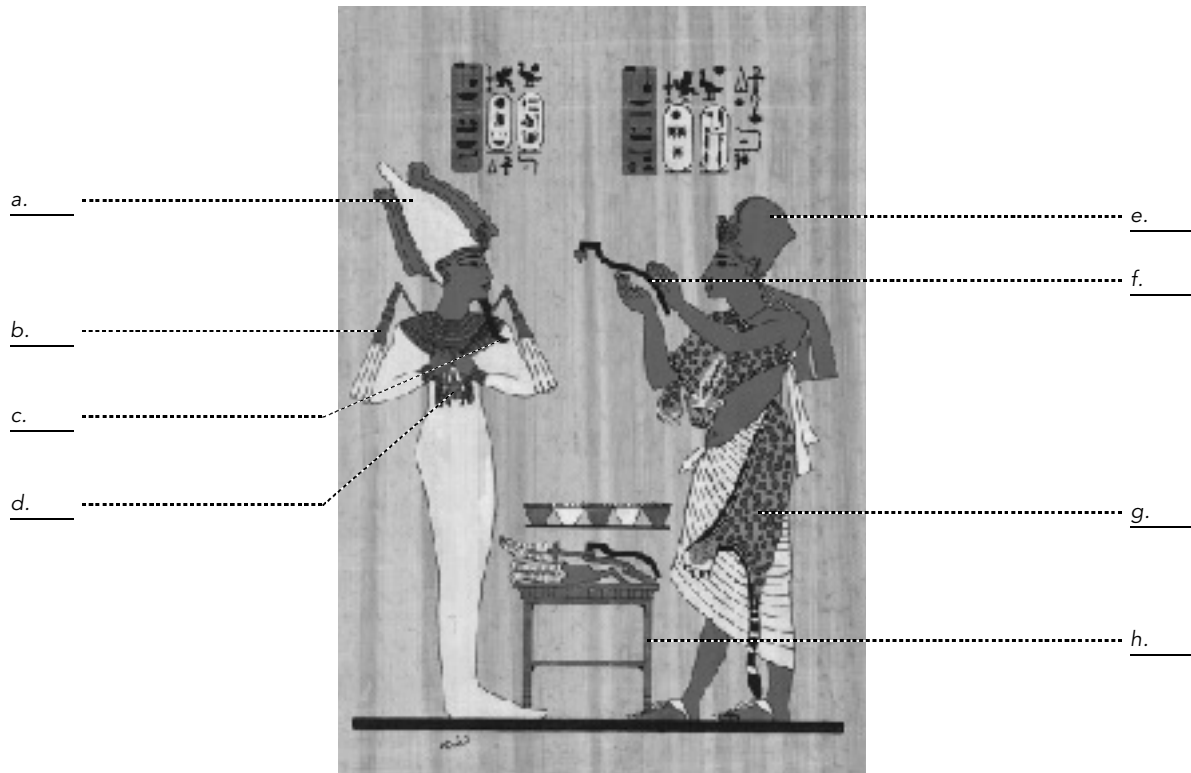

Clues

- | | | |
|---------------------------------|--------------------|--------------------------------|
| 1. leopard skin | 4. scarab pendant | 7. atef (double-feather) crown |
| 2. tool for “opening the mouth” | 5. pharaoh’s beard | 8. blue crown |
| 3. flail | 6. offering table | |



ACTIVITY SHEET 29

Men's Work

We can learn about the daily life of the ancient Egyptians by looking at these tomb paintings. Next to each letter, write the number that corresponds to the description. On another sheet of paper, write a sentence to describe what the men in each painting are doing or what their role is.

a. _____



CMC S97 10779

e. _____



CMC S97 10777

b. _____



CMC S97 10774

f. _____



CMC S97 10798

c. _____



CMC S97 10793

g. _____



CMC S97 10791

d. _____



CMC S97 10775

h. _____



CMC S97 10796

Drawings by Winnifred Needler, courtesy of the Royal Ontario Museum

Clues

- | | | | |
|---------------------|---------------------|----------------|----------------------|
| 1. crushing grapes | 3. ploughing fields | 5. beadwork | 7. craftsmen |
| 2. harvesting wheat | 4. carpenters | 6. brickmaking | 8. irrigating fields |



ACTIVITY SHEET 30

Women's Work and Leisure

We can learn about the daily life of the ancient Egyptians by looking at tomb paintings. Next to each letter, write the number that corresponds to the description. On another piece of paper, write a sentence to describe what the women in each painting are doing or what their role is.

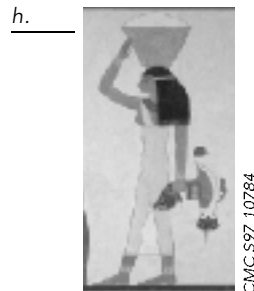

Drawings by Winnifred Needler, courtesy of the Royal Ontario Museum

Clues













1. musicians	3. spinning flax	5. weaving	7. maid delivering food
2. dancers	4. child care	6. receiving wine	8. receiving perfume



ACTIVITY SHEET 31 Reading Hieroglyphs

There are three major types of signs in hieroglyphic writing: 1) logograms, which represent words; 2) phonograms, which represent sounds; and 3) determinatives, which help to indicate the precise meaning of words.









1. Write the meaning of each logogram.

a.  _____	d.  _____	g.  _____	j.  _____
b.  _____	e.  _____	h.  _____	k.  _____
c.  _____	f.  _____	i.  _____	l.  _____

Clues

- | | | | |
|------------|------------|--------------|--------------|
| 1. sun | 4. face | 7. woman | 10. plant |
| 2. to come | 5. horizon | 8. man | 11. to break |
| 3. house | 6. to cut | 9. to strike | 12. gold |



2. Write the sound that corresponds to these phonograms.

a.  _____	c.  _____	e.  _____	g.  _____
b.  _____	d.  _____	f.  _____	h.  _____

Clues









- | | |
|---|---|
| 1. <i>bit</i> (looks like it could sting you) | 5. <i>hr</i> (looks like a man) |
| 2. <i>ir</i> (looks like it could see you) | 6. <i>ms</i> (looks like three fox tails) |
| 3. <i>stp</i> (looks like a hammer) | 7. <i>mr</i> (looks like a plough) |
| 4. <i>sw</i> (looks like a blade of grass) | 8. <i>hpr</i> (crawls) |

Determinatives were derived from logograms. They were placed at the end of a set of hieroglyphs to clarify the meaning of the word. Here are two examples:

When a logogram of a scribe's palette  is followed by the determinative depicting a man , the word means "scribe". When it is followed by a scroll , it means "to write".



3. Identify the meaning of these determinatives.

- a.  _____ c.  _____ e.  _____ g.  _____
- b.  _____ d.  _____ f.  _____ h.  _____

Clues

- | | | | |
|-------------------|----------|-----------------|----------------|
| 1. horse | 3. god | 5. enemy | 7. small, weak |
| 2. vine or garden | 4. child | 6. tree or wood | 8. dancing man |

4. Hieroglyphic inscriptions are written in horizontal lines or vertical columns, and usually read from top to bottom. The faces of the hieroglyphic signs representing people or animals are always turned towards the beginning of the text. In these four examples from the *Book of the Dead*, indicate where you would begin reading the text and where you would finish.

A

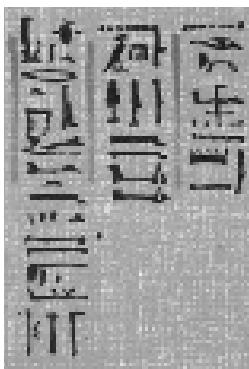

B

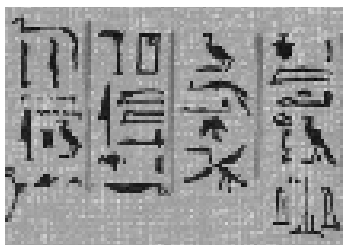

C



D



	START		FINISH
A	_____		
B	_____		
C	_____		
D	_____		









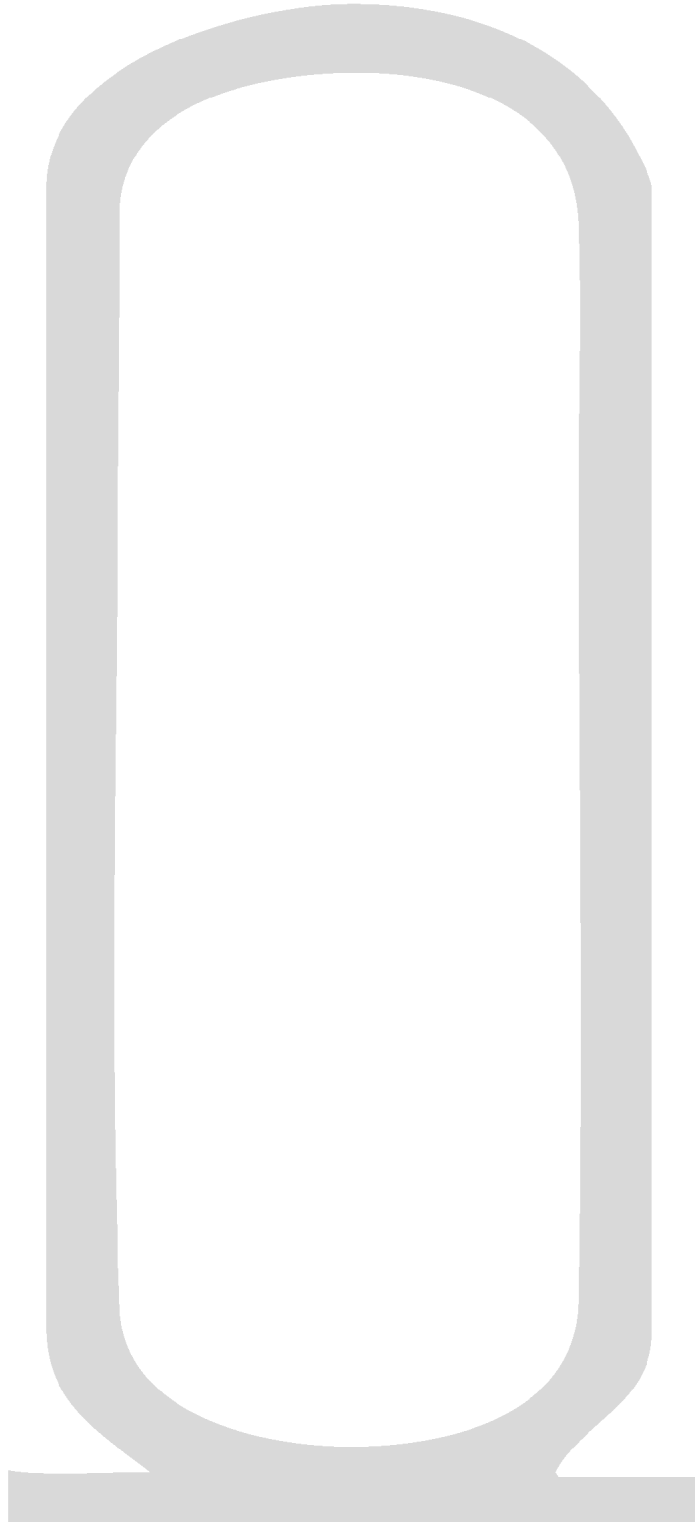



















ACTIVITY SHEET 32

Make Your Own Cartouche

1. The names of pharaohs and royals were written inside cartouches. Use the hieroglyphic alphabet to write your name inside the cartouche provided.



2. Beside each hieroglyphic symbol, write what you think the symbol represents.

A  _____	J  _____	S  _____
B  _____	K  _____	T  _____
C  _____	L  _____	U  _____
D  _____	M  _____	V  _____
E  _____	N  _____	W  _____
F  _____	O  _____	X  _____
G  _____	P  _____	Y  _____
H  _____	Q  _____	Z  _____
I  _____	R  _____	

Clues

- | | | | |
|-----------------------------|-------------------|---------------|----------------------|
| 1. water | 6. hand | 12. reed leaf | 18. folded cloth |
| 2. foot | 7. horned snake | 13. lion | 19. two reed leaves |
| 3. stool | 8. lasso | 14. vulture | 20. chequered basket |
| 4. plain basket with handle | 9. cobra | 15. mat | 21. door bolt |
| 5. baby quail | 10. loaf of bread | 16. courtyard | 22. mouth |
| | 11. hillside | 17. owl | |



ACTIVITY SHEET 33

Mathematics

The standard unit of linear measure used in ancient Egypt was the royal cubit, equivalent to 52.3 cm (20.6 in.). It represented the length of the pharaoh's forearm, from the elbow to the tip of the thumb. Measure the length of your forearm, from your elbow to the tip of your thumb. How much longer was the Egyptian pharaoh's forearm? _____

Use the table below to read and write numbers in hieroglyphs. The higher numbers are usually written in front of the lower ones. When there is more than one row of numbers, start at the top and read down.

	1	∩	10	∩	100	☛	1,000	∩	10,000	☛	100,000	☛	1,000,000
--	---	---	----	---	-----	---	-------	---	--------	---	---------	---	-----------

1. What numbers do the following hieroglyphs represent?

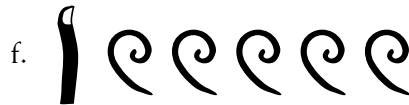
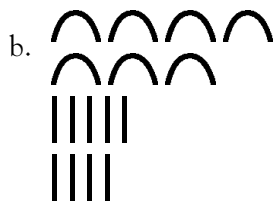
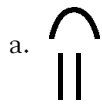

2. Write the following numbers in hieroglyphs.

a. 19 _____

e. 3,134 _____

b. 56 _____

f. 1,400 _____

c. 374 _____

g. 10,738 _____

d. 547 _____

h. 1,400,225 _____

3. Make up your own numbers and write them in hieroglyphs.