 Health Canada Santé Canada	Title of publication-Titre de la publication Product Safety Laboratory Book 5 - Laboratory Policies and Procedures	Page 1 of 15	Effective En vigueur 2007-04-20
Chapter and/or Section;-Number and title-Chapitre ou section-Numéro et titre Part B: Test Methods Section, Method M-09 TEST PROCEDURES FOR PACIFIERS AND OTHER SIMILAR CONSUMER PRODUCTS			Amendment number- Numéro de la modification 43

1 SCOPE AND PURPOSE

- 1.1 This method describes procedures for testing pacifiers and similar products described in item 27 of Part II of Schedule I to the Hazardous Products Act (HPA) to determine if they meet the applicable requirements set out in the Hazardous Products (Pacifiers) Regulations. Since the numerical values of performance measures are based upon regulatory requirements, the tolerances for these values have been chosen such that no test parameter is applied to the product that results in a more severe condition than that specified in the regulation, with the understanding that uncertainty of measurement is always present. The product is evaluated by performing the test procedures specified in Section 5.

2 APPLICABLE DOCUMENTS

- 2.1 The Hazardous Products Act (HPA).
- 2.2 HPA, Hazardous Products (Pacifiers) Regulations (C.930) hereinafter referred to as the Regulations.
- 2.3 PSL Project Report 2006:0952 Test Method Revision of M09: TEST PROCEDURES FOR PACIFIERS AND OTHER SIMILAR CONSUMER PRODUCTS.
- 2.4 Book 5, Reference Manual, Laboratory Policies and Procedures, Product Safety Laboratory (PSL) hereinafter referred to as Book 5.
- 2.5 Test Method M00.1: Test Procedures to Determine Mechanical Hazards - Small Components-, Book 5.
- 2.6 Test Method M00.2: Test Procedures to Determine Mechanical Hazards (Sharp Edges), Book 5.
- 2.7 Test Method M00.3: Test Procedures to Determine Mechanical Hazards (Sharp Points), Book 5.

 Health Canada / Santé Canada	Title of publication-Titre de la publication Product Safety Laboratory Book 5 - Laboratory Policies and Procedures	Page 2 of 15	Effective En vigueur 2007-04-20
Chapter and/or Section;-Number and title-Chapitre ou section-Numéro et titre Part B: Test Methods Section, Method M-09 TEST PROCEDURES FOR PACIFIERS AND OTHER SIMILAR CONSUMER PRODUCTS			Amendment number-Numéro de la modification 43

2.8 General Guidelines for Evaluating and Expressing the Uncertainty of Accredited Laboratories' Measurement Results, CLAS Reference Document 5, May 1999.

3 SAMPLING

3.1 The following test procedures should be conducted on 10 sample elements.

4 APPARATUS

- 4.1 Clamp suitable for grasping and holding the nipple of the pacifier.
- 4.2 Clamp suitable for grasping and holding the pacifier handle.
- 4.3 Clamp suitable for grasping and holding the pacifier guard or shield.
- 4.4 Suitable force adjustable nipple clamp, such as illustrated in Figure 11.
- 4.5 A mass or device with a plane surface that can apply a force of $8.9 \text{ N} \pm 0.1 \text{ N}$.
- 4.6 Hotplate or suitable heating element.
- 4.7 Marker, water resistant ink.
- 4.8 Metric measuring device with a resolution of 1 mm or better.
- 4.9 Guard template, as illustrated in Figure 1.
- 4.10 Large stainless steel container for boiling water.
- 4.11 A stopwatch with a resolution of 0.1 seconds or better.
- 4.12 Test stand to attach clamps.
- 4.13 A mass, which when added to the mass of the clamp, will lie within $0.97 \text{ kg} \pm 0.03 \text{ kg}$.
- 4.14 A mass, which when added to the mass of the clamp, will lie within $4.54 \text{ kg} \pm 0.12 \text{ kg}$.
- 4.15 Small Parts Cylinder, as illustrated in Figure 2.
- 4.16 Wire mesh or steamer-type retaining basket.
- 4.17 Temperature measuring device with a resolution of 1°C or better.

5 TESTING PROCEDURES

 Health Canada / Santé Canada	Title of publication-Titre de la publication Product Safety Laboratory Book 5 - Laboratory Policies and Procedures	Page 3 of 15	Effective En vigueur 2007-04-20
Chapter and/or Section;-Number and title-Chapitre ou section-Numéro et titre Part B: Test Methods Section, Method M-09 TEST PROCEDURES FOR PACIFIERS AND OTHER SIMILAR CONSUMER PRODUCTS			Amendment number- Numéro de la modification 43

- 5.1 Note and record if the product meets the requirements in 4(1) and 4(2) of the Regulations.
- 5.2 Label each sample element with an identifying mark (for later use as a test orientation reference point) using a water resistant ink marker. Refer to Figure 7.
- 5.3 Note and record whether any ring or handle of the pacifier is hinged, collapsible or flexible, or if the handle is a knob-type that isn't hinged, collapsible or flexible.
- 5.4 Note and record whether there is a loop of cord or other material attached to the pacifier. If any such attachment is present, measure and record the circumference of the item to the nearest 1 mm.
- 5.5 **Protrusion Test:** (*Note 1*)
 - 5.5.1 Secure the pacifier, with the axis of the nipple horizontal or vertical, such that the guard or shield is held fixed. Any hinged handle or ring shall have its hinge axis horizontal and shall be allowed to rotate under the influence of its own weight.
 - 5.5.2 Using a mass or device with a plane surface, slowly apply an 8.9 N \pm 0.1 N load towards the protrusion on the pacifier in a direction normal and central to the plane surface, that aligns with the axis of the nipple (see Figure 10). Allow any flexible component to buckle or bend and continue the load application until 8.9 N \pm 0.1 N of loading is applied. A pacifier which has a ring, handle or other protrusion which is fabricated from a nonrigid material, but which does not deflect under the influence of its own weight, may be manually deflected as the plane face is brought towards it, if by doing so, its resistance to deflection is not greater than the resistance it would offer if it wasn't deflected.

Note 1: This Protrusion Test is applicable to pacifiers that have a handle, including a knob-like handle, that is not hinged, collapsible or flexible. The Protrusion Test is taken from the United States Code of Federal Regulations, Title 16 Part 1511.4. The requirements for protrusion will be revised to eventually include all designs of pacifiers.

 Health Santé Canada Canada	Title of publication-Titre de la publication Product Safety Laboratory Book 5 - Laboratory Policies and Procedures	Page 4 of 15	Effective En vigueur 2007-04-20
Chapter and/or Section;-Number and title-Chapitre ou section-Numéro et titre Part B: Test Methods Section, Method M-09 TEST PROCEDURES FOR PACIFIERS AND OTHER SIMILAR CONSUMER PRODUCTS			Amendment number- Numéro de la modification 43

5.5.3 While maintaining the $8.9 \text{ N} \pm 0.1 \text{ N}$ load, measure the protrusion distance from the plane face to the face of the shield at the base of the nipple as illustrated by Figure 10.

5.5.4 Repeat steps 5.5.1 through 5.5.3 with the remaining sample elements.

5.5.5 Results

5.5.5.1 Record the protrusion distance for each sample element tested.

5.6 Nipple tear:

5.6.1 If, at any time during the following tests of 5.7 and 5.8, a tear or break visibly appears on the nipple around the immediate vicinity of the clamp, cease testing. The tests of 5.7 and 5.8 must be repeated in their entirety using a suitable clamp such as the one described in Figure 11 on 10 pristine sample elements of the same sample. Using this clamp and one or two or as many extra pristine sample elements are necessary, determine the minimum applied clamping force at which slippage between the clamp and nipple does not occur. Record this force. Increase this clamping force by 25% and apply it to the nipples, as required, of 10 pristine sample elements of the same sample in performing tests 5.7 and 5.8.

5.7 Guard Test:

5.7.1 Place the pacifier in the guard template, illustrated in Figure 1, with the nipple of the pacifier centered in the opening of the template (see *Note 2 and Figure 3*). Attach the nipple clamp to the nipple. Gradually apply a mass ($0.97 \text{ kg} \pm 0.03 \text{ kg}$ including the mass of the clamp) to the nipple clamp within 5 seconds and allow the load to hang freely for 10 seconds ($\pm 1 \text{ sec}$). See Figure 4.

Note 2: For pacifiers with non-circular mouth guards or shields, place the pacifier on the template with the nipple of the pacifier centered in the opening of the template with the major axis of the mouth guard or shield *parallel* with the major axis of the opening in the template, as illustrated in Figure 3.

 Health Canada / Santé Canada	Title of publication-Titre de la publication Product Safety Laboratory Book 5 - Laboratory Policies and Procedures	Page 5 of 15	Effective En vigueur 2007-04-20
Chapter and/or Section;-Number and title-Chapitre ou section-Numéro et titre Part B: Test Methods Section, Method M-09 TEST PROCEDURES FOR PACIFIERS AND OTHER SIMILAR CONSUMER PRODUCTS			Amendment number-Numéro de la modification 43

5.7.2 Note whether the guard or shield passed through the opening in the template.

5.7.3 Repeat steps 5.7.1 and 5.7.2 with the remaining sample elements.

5.7.4 Results

5.7.4.1 Record whether the guard or shield of any pacifier passed through the opening in the template.

5.8 Structural Integrity Test:

Note: Perform the following three structural integrity tests (5.8.1 - 5.8.3) consecutively on the same sample element prior to testing the next sample element. Doing so reduces the stress incurred by the nipple from the frequent clamping and unclamping action of the test equipment.

5.8.1 Attach a nipple clamp to the nipple of the pacifier and affix the handle of the pacifier to the test stand. See Figure 5. If the pacifier has only a knob, attach a knob clamp to the knob and affix the knob clamp to the test stand (see Figure 6). If the knob is constructed so that it can't be grasped by the clamp, record that it can't be grasped and proceed to 5.8.3. Gradually apply a mass ($4.54 \text{ kg} \pm 0.12 \text{ kg}$ including the mass of the nipple clamp) to the pacifier over a period of 10 seconds ($\pm 2 \text{ sec}$) such that the load is applied axially to the nipple. Allow the load to hang freely for 10 seconds ($\pm 0.5 \text{ sec}$). Observe any damage. Store any components that have separated for further evaluation in step 5.8.6. Discontinue testing (only for the specific sample element under test) if the nipple or handle is detached, but continue testing if only a partial separation is observed.

5.8.2 Clamp the guard or shield of the pacifier on the test stand in a fixed position using the test orientation guide shown in Figure 7. If the pacifier has only a knob, attach a knob clamp to the knob and gradually apply a mass ($4.54 \text{ kg} \pm 0.12 \text{ kg}$ including the mass of the knob clamp). Gradually apply a mass ($4.54 \text{ kg} \pm 0.12 \text{ kg}$) to the handle of the pacifier over a period of 10 seconds ($\pm 2 \text{ sec}$) such

 Health Santé Canada Canada	Title of publication-Titre de la publication Product Safety Laboratory Book 5 - Laboratory Policies and Procedures	Page 6 of 15	Effective En vigueur 2007-04-20
Chapter and/or Section;-Number and title-Chapitre ou section-Numéro et titre Part B: Test Methods Section, Method M-09 TEST PROCEDURES FOR PACIFIERS AND OTHER SIMILAR CONSUMER PRODUCTS			Amendment number- Numéro de la modification 43

that the load is applied at right angles to the axis of the nipple. Allow the load to hang freely for 10 seconds (± 0.5 sec). See Figure 8. Observe any damage. Store any components that have separated for further evaluation in step 5.8.6. Discontinue testing (only for the specific sample element under test) if the handle has detached, but continue testing if only a partial separation is observed.

- 5.8.3 Clamp the guard or shield of the pacifier on the test stand in a fixed position using the same guard orientation as that used in step 5.8.2. Attach a clamp to the nipple of the pacifier. Gradually apply a mass ($4.54 \text{ kg} \pm 0.12 \text{ kg}$ including the mass of the clamp) to the nipple clamp over a period of 10 seconds (± 2 sec) such that the load is applied at right angles to the axis of the nipple. Allow the load to hang freely for 10 seconds (± 0.5 sec). See Figure 9. Observe any damage. Store any components that have separated for further evaluation in step 5.8.6. Discontinue testing (only for the specific sample element under test) if the nipple has detached, but continue testing if only a partial separation is observed.
- 5.8.4 Place all sample elements in a wire mesh or steamer-type retaining basket and immerse the basket in boiling water for 10 minutes ± 0.5 minutes. Remove the pacifiers from the boiling water and allow to cool in air at $21 \text{ }^\circ\text{C} \pm 3^\circ\text{C}$ for 15 minutes ± 0.5 minutes. Repeat steps 5.8.1 through 5.8.3.
- 5.8.5 Repeat the entire procedure described in step 5.8.4 an additional nine times. In proceeding with steps 5.8.2 and 5.8.3 after each boil/cool cycle, rotate the pacifier's guard or shield 90 degrees clockwise about the axis of the nipple, as shown in Figure 7, prior to clamping the guard or shield in a fixed position.
- 5.8.6 Observe whether any part or component that has separated or broken free from the pacifier can be totally enclosed, in a non-compressed state, into the small parts cylinder. Conduct this test as described in Test Method M00.1 Test Procedures to Determine Mechanical Hazards (Small Components) on any components that were detached during the test in sections 5.8.1, 5.8.2 and 5.8.3. Do

 Health Santé Canada Canada	Title of publication-Titre de la publication Product Safety Laboratory Book 5 - Laboratory Policies and Procedures	Page 7 of 15	Effective En vigueur 2007-04-20
Chapter and/or Section;-Number and title-Chapitre ou section-Numéro et titre Part B: Test Methods Section, Method M-09 TEST PROCEDURES FOR PACIFIERS AND OTHER SIMILAR CONSUMER PRODUCTS			Amendment number- Numéro de la modification 43

not perform sections 5.2.1 and 5.2.2 of Test Method M00.1. These sections apply only to detached components of toys.

5.8.7 Observe whether any part or component that has separated or broken free from the pacifier has any Sharp Edges or Points. Conduct these tests as described in Test Method M00.2 Test Procedures to Determine Mechanical Hazards (Sharp Edges), and Test Method M00.3 Test Procedures to Determine Mechanical Hazards (Sharp Points).

5.8.8 Results

5.8.8.1 Record the details of any damage to each sample element including reference to the exact stage of testing (test and boil number).

6 QUALITY ASSURANCE/QUALITY CONTROL PROCEDURES

6.1 Ensure that all measuring instruments are functional and are calibrated with traceability to national or international standards.

6.2 Testing and the results obtained according to this method include uncertainty associated with the:

(i) uncertainty of any or all calibrations by an accredited calibration laboratory of the apparatus stated and used in this method,

(ii) standard uncertainty or standard deviation of a series of repeated measurements of masses or with instruments stated and used in this method (documented in the Equipment Record binder),

(iii) a coverage factor ($k = 2$) to express an expanded uncertainty ($U = ku_c$, where u_c is the combined standard uncertainty) for a level of confidence of approximately 95%, assuming normal distribution (Reference: General Guidelines for Evaluating and Expressing the Uncertainty of Accredited Laboratories' Measurement Results, CLAS Reference Document 5, May 1999).

 Health Santé Canada Canada	Title of publication-Titre de la publication Product Safety Laboratory Book 5 - Laboratory Policies and Procedures	Page 8 of 15	Effective En vigueur 2007-04-20
Chapter and/or Section;-Number and title-Chapitre ou section-Numéro et titre Part B: Test Methods Section, Method M-09 TEST PROCEDURES FOR PACIFIERS AND OTHER SIMILAR CONSUMER PRODUCTS			Amendment number- Numéro de la modification 43

6.3 The principal uncertainties associated with this method are due to:

- (i) Variations in the application of the test procedure due to personnel conducting the test.
- (ii) Uncertainty associated with the measuring instruments.

7 TEST REPORT

7.1 The test report should contain the following information:

- 7.1.1 A description of the product to include (where available), brand, style, country of origin, photo, UPC and other pertinent information.
- 7.1.2 The number of sample elements tested.
- 7.1.3 The results of the tests (conducted in the sequence presented in section 5 of this test method) with specific details for any potential problems observed.
- 7.1.4 If required, the minimum applied clamping force as per 5.6.1 at which slippage does not occur, and its value increased by 25%.
- 7.1.5 The analyst's name and signature, as well as the name(s) and signature(s) of the reviewer(s).

 Health Santé Canada Canada	Title of publication-Titre de la publication Product Safety Laboratory Book 5 - Laboratory Policies and Procedures	Page 9 of 15	Effective En vigueur 2007-04-20
Chapter and/or Section;-Number and title-Chapitre ou section-Numéro et titre Part B: Test Methods Section, Method M-09 TEST PROCEDURES FOR PACIFIERS AND OTHER SIMILAR CONSUMER PRODUCTS			Amendment number- Numéro de la modification 43

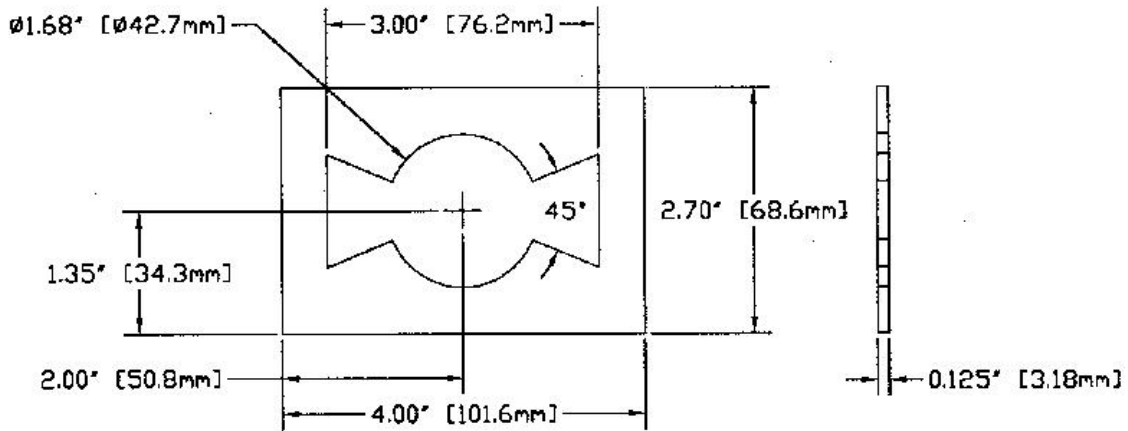

NOTE:

1. Radius of all edges of openings to be 0.030"/0.76 mm
2. Material to be aluminum plate
3. Dimensional tolerance ± 0.005 "/0.13 mm

FIGURE 1. GUARD TEMPLATE



 Health Santé Canada Canada	Title of publication-Titre de la publication Product Safety Laboratory Book 5 - Laboratory Policies and Procedures	Page 10 of 15	Effective En vigueur 2007-04-20
Chapter and/or Section;-Number and title-Chapitre ou section-Numéro et titre Part B: Test Methods Section, Method M-09 TEST PROCEDURES FOR PACIFIERS AND OTHER SIMILAR CONSUMER PRODUCTS			Amendment number- Numéro de la modification 43

FIGURE 2. SMALL PARTS CYLINDER

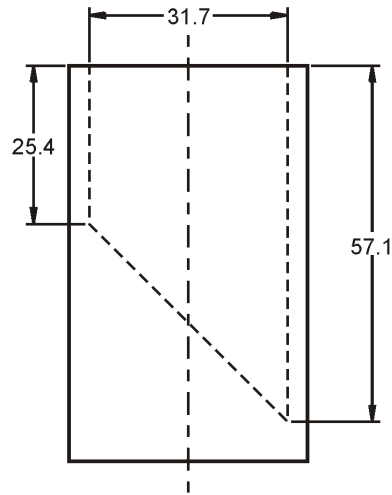

- Notes:
- Not to scale
 - All dimensions in mm

 Health Santé Canada Canada	Title of publication-Titre de la publication Product Safety Laboratory Book 5 - Laboratory Policies and Procedures	Page 11 of 15	Effective En vigueur 2007-04-20
Chapter and/or Section;-Number and title-Chapitre ou section-Numéro et titre Part B: Test Methods Section, Method M-09 TEST PROCEDURES FOR PACIFIERS AND OTHER SIMILAR CONSUMER PRODUCTS			Amendment number- Numéro de la modification 43

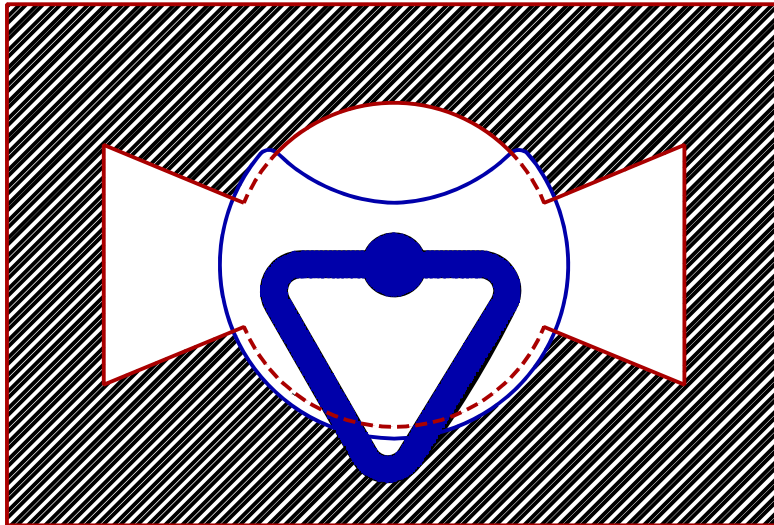

FIGURE 3. PACIFIER ON GUARD TEMPLATE (procedure 5.7.1, Note 2)

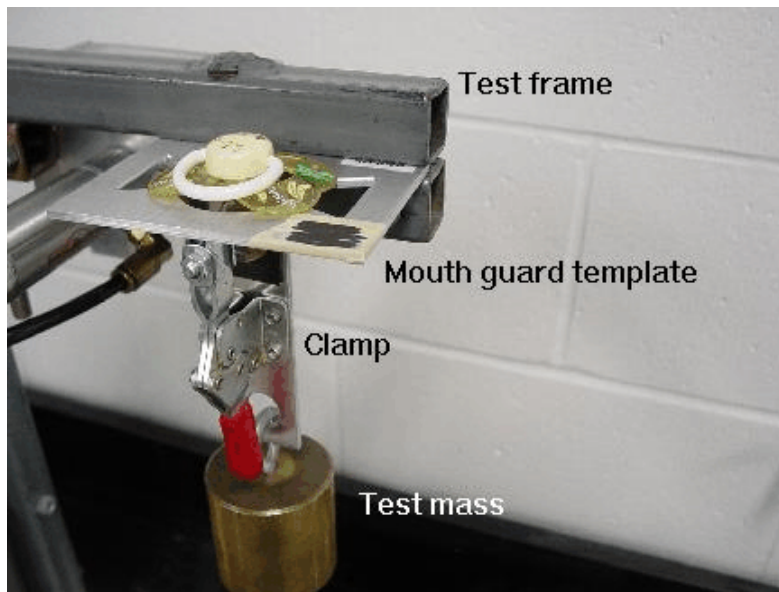



FIGURE 4. GUARD TEST

 Health Canada / Santé Canada	Title of publication-Titre de la publication Product Safety Laboratory Book 5 - Laboratory Policies and Procedures	Page 12 of 15	Effective En vigueur 2007-04-20
Chapter and/or Section;-Number and title-Chapitre ou section-Numéro et titre Part B: Test Methods Section, Method M-09 TEST PROCEDURES FOR PACIFIERS AND OTHER SIMILAR CONSUMER PRODUCTS			Amendment number- Numéro de la modification 43

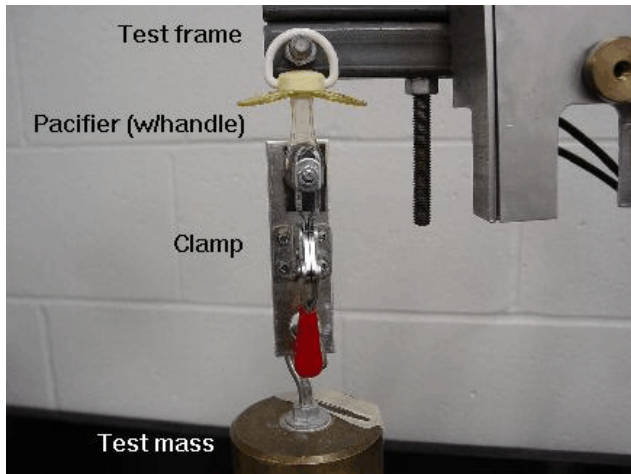

Figure 5: STRUCTURAL INTEGRITY TEST (procedure 5.8.1, pacifier w/handle).

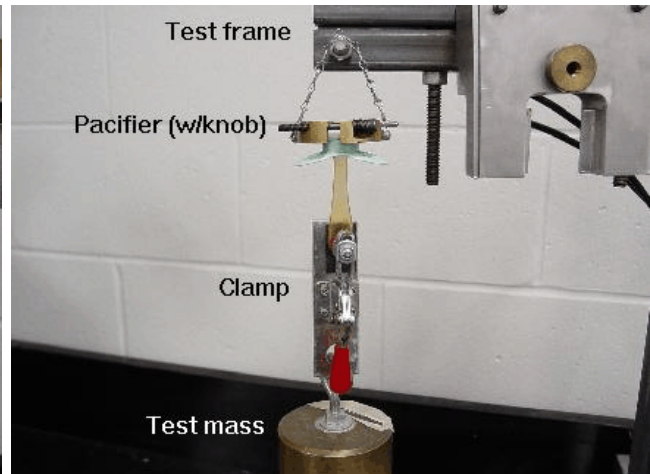

Figure 6: STRUCTURAL INTEGRITY TEST (procedure 5.8.1, pacifier w/knob).

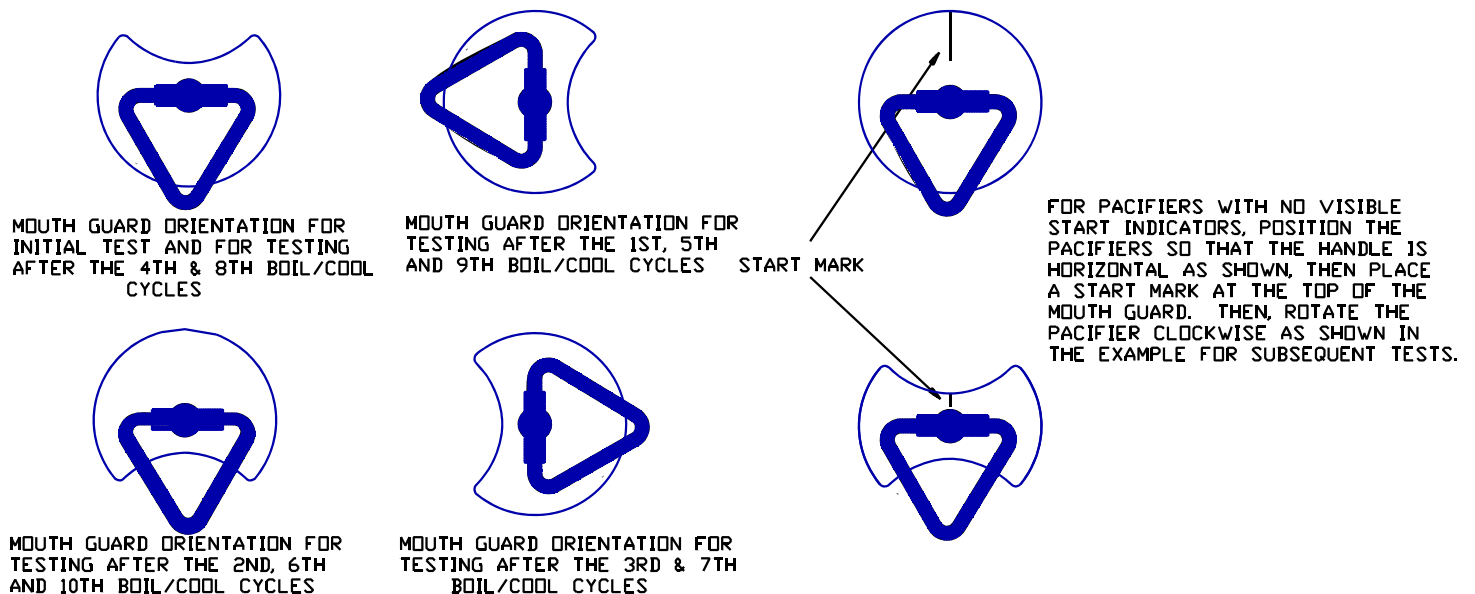



FIGURE 7. ORIENTATION OF GUARD OR SHIELD FOR STRUCTURAL INTEGRITY TESTS

 Health Canada / Santé Canada	Title of publication-Titre de la publication Product Safety Laboratory Book 5 - Laboratory Policies and Procedures	Page 13 of 15	Effective En vigueur 2007-04-20
Chapter and/or Section;-Number and title-Chapitre ou section-Numéro et titre Part B: Test Methods Section, Method M-09 TEST PROCEDURES FOR PACIFIERS AND OTHER SIMILAR CONSUMER PRODUCTS			Amendment number- Numéro de la modification 43

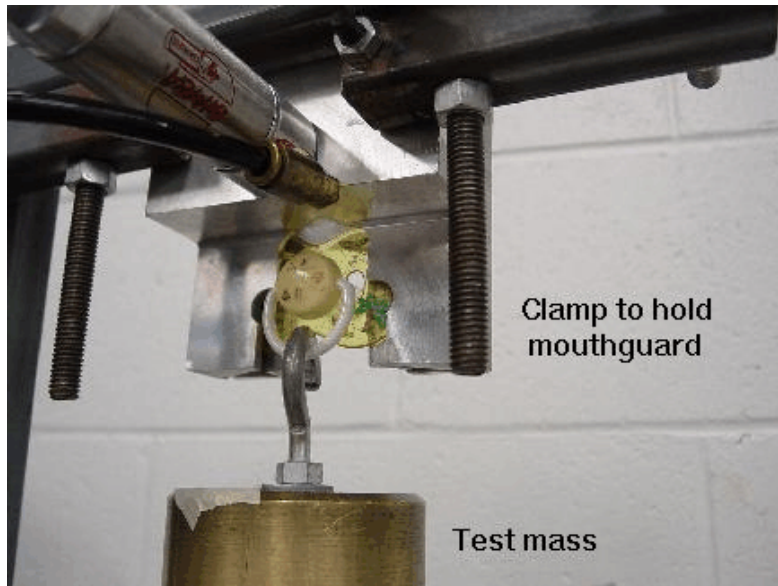

FIGURE 8. STRUCTURAL INTEGRITY TEST (procedure 5.8.2)

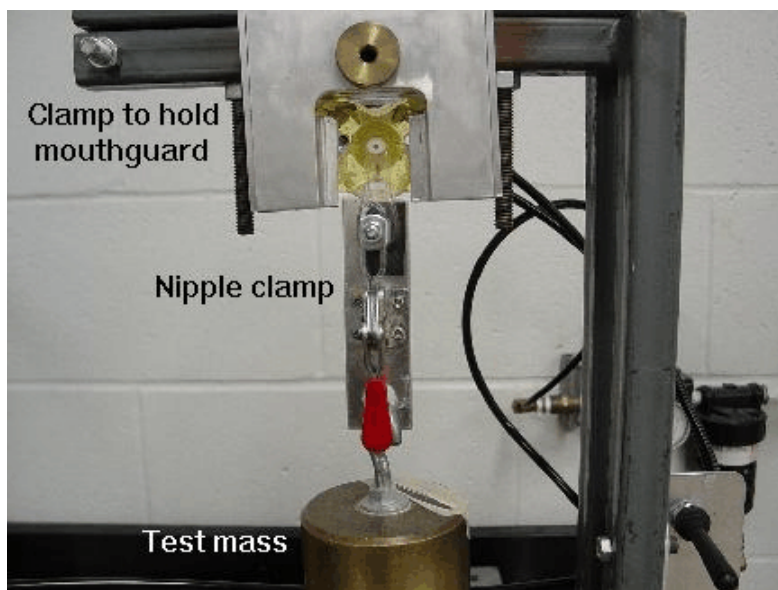



FIGURE 9. STRUCTURAL INTEGRITY TEST (procedure 5.8.3)

 Health Santé Canada Canada	Title of publication-Titre de la publication Product Safety Laboratory Book 5 - Laboratory Policies and Procedures	Page 14 of 15	Effective En vigueur 2007-04-20
Chapter and/or Section;-Number and title-Chapitre ou section-Numéro et titre Part B: Test Methods Section, Method M-09 TEST PROCEDURES FOR PACIFIERS AND OTHER SIMILAR CONSUMER PRODUCTS			Amendment number- Numéro de la modification 43

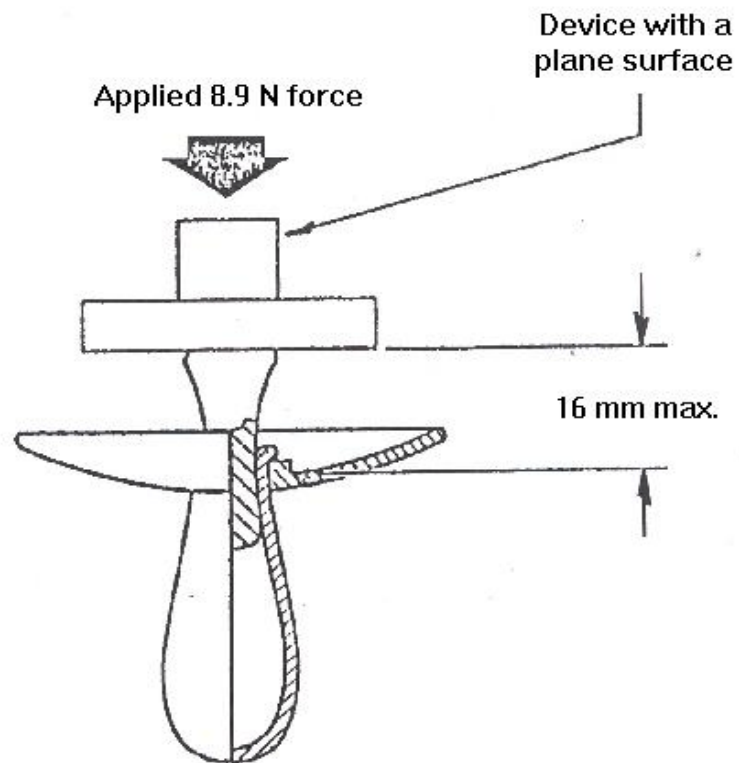

FIGURE 10. DIMENSIONAL REQUIREMENT IN PROTRUSION TEST

 Health Canada / Santé Canada	Title of publication-Titre de la publication Product Safety Laboratory Book 5 - Laboratory Policies and Procedures	Page 15 of 15	Effective En vigueur 2007-04-20
Chapter and/or Section;-Number and title-Chapitre ou section-Numéro et titre Part B: Test Methods Section, Method M-09 TEST PROCEDURES FOR PACIFIERS AND OTHER SIMILAR CONSUMER PRODUCTS			Amendment number-Numéro de la modification 43



FIGURE 11. FORCE ADJUSTABLE NIPPLE CLAMP

Mass of clamp used by PSL: 252 grams. Mass of clamp used combined with test mass shall remain within the tolerance(s) specified in the method for applying load(s).

Nominal clamp contact diameter: 12.7 mm (0.5 inch).

..... END