



Transport Canada
Safety and Security

Transports Canada
Sécurité et sûreté

Road Safety

Sécurité routière

Standards and Regulations Division

TEST METHOD 210

Seat Belt Anchorages

Revised: January 2006
Issued: December 1996

Standards Research and Development Branch
Road Safety and Motor Vehicle Regulation Directorate
TRANSPORT CANADA
Ottawa, Ontario
K1A 0N5

TABLE OF CONTENTS

1. Introduction.....1

2. Strength Test Conditions.....1

2.1 Anchorages for a Type 1 Seat Belt Assembly or the Pelvic Portion of a Type 2 Seat Belt Assembly that is Equipped with a Detachable Upper Torso Restraint1

2.2 Anchorages for the Pelvic Portion and the Upper Torso Portion of a Type 2 Seat Belt Assembly.....3

2.3 Adjustment in the Case of Interference between the Pelvic Body Block and the Belt Buckle.....4

TABLE OF FIGURES

Figure 1 — Body Block for the Lap Belt Anchorage.....2

Figure 2 — Alternative Body Block for Centre Positions.....3

Figure 3 — Body Block for a Combination Shoulder-and-Lap-Belt Anchorage.....4

1. Introduction

Test Method 210 — Seat Belt Anchorages (January 2006) is to be used for demonstrating compliance with the requirements of section 210 of Schedule IV to the *Motor Vehicle Safety Regulations*.

(Original signed by)

Director, Standards Research and Development
for the Minister of Transport, Infrastructure
and Communities
Ottawa, Ontario

2. Strength Test Conditions

2.1 *Anchorages for a Type 1 Seat Belt Assembly or the Pelvic Portion of a Type 2 Seat Belt Assembly that is Equipped with a Detachable Upper Torso Restraint*

- 2.1.1 The strength of the anchorages for a Type 1 seat belt assembly or the pelvic portion of a Type 2 seat belt assembly that is equipped with a detachable upper torso restraint shall be tested
- (a) by placing the seat in its rearmost position on a plane parallel to the longitudinal centreline of the vehicle,
 - (b) by positioning the pelvic body block illustrated in Figure 1 as specified in subsection 2.3 and by restraining the pelvic body block by:
 - (i) a Type 1 seat belt assembly,
 - (ii) the pelvic portion of a Type 2 seat belt assembly, or
 - (iii) material whose breaking strength is equal to or greater than the breaking strength of the webbing for the seat belt assembly that was installed as original equipment at that seating position, provided that, at the initiation of the test, the geometry and the attachment duplicate those of the originally installed seat belt assembly, and
-

- (c) by applying and maintaining a force of 22 241 N to the pelvic body block for 10 seconds in the direction in which the seat faces,
- (d) with the initial application angle of the force being not less than 5° and not more than 15° above the horizontal plane and
- (e) with the onset rate of the force being not more than 222 411 N/s so as to attain the 22 241-N force in not more than 30 seconds.

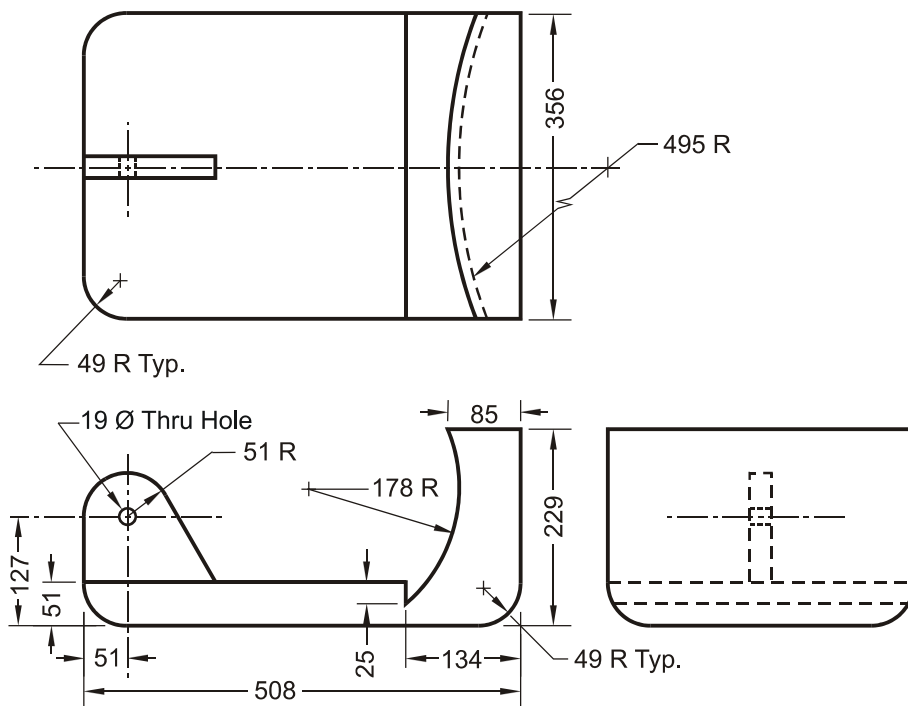

Notes:

1. The block is covered by 25-mm, medium-density, canvas-covered foam rubber.
2. All dimensions are in mm with a tolerance of ± 1 .
3. Not to scale

Figure 1 — Body Block for the Lap Belt Anchorage

2.1.2 Alternative Pelvic Body Block

In order to apply a force to the centre set of anchorages for a group of three or more adjacent sets of anchorages, the alternative pelvic body block illustrated in Figure 2 may, at the option of the manufacturer, be substituted for the pelvic body block illustrated in Figure 1.

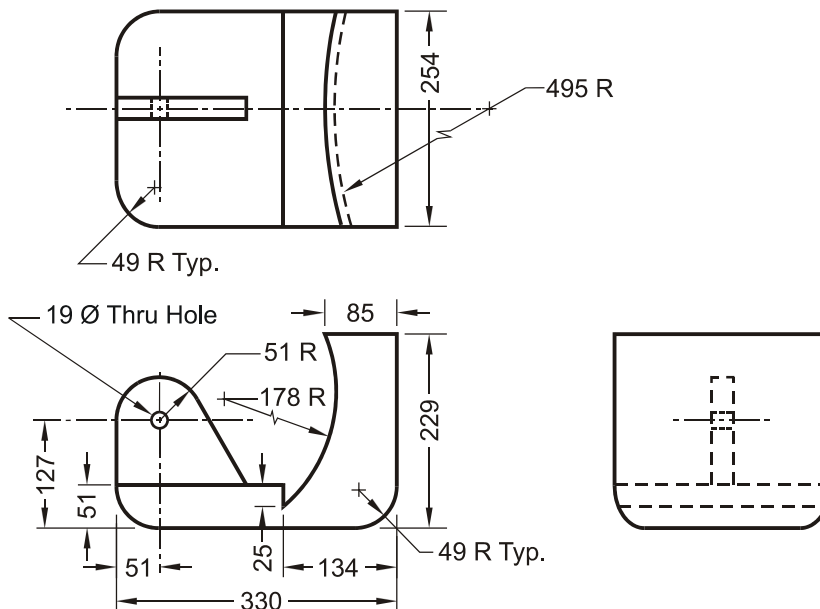

Notes:

1. The block is covered by 25-mm, medium-density, canvas-covered foam rubber.
2. All dimensions are in mm with a tolerance of ± 1 .
3. Not to scale

Figure 2 — Alternative Body Block for Centre Positions

2.2 *Anchorages for the Pelvic Portion and the Upper Torso Portion of a Type 2 Seat Belt Assembly*

- 2.2.1 The strength of the anchorages for the pelvic portion and the upper torso portion of a Type 2 seat belt assembly shall be tested
- (a) by placing the seat in its rearmost position on a plane parallel to the longitudinal centreline of the vehicle,
 - (b) by positioning the body block as specified in subsection 2.3 and by restraining the pelvic body block by a Type 2 seat belt assembly as follows:
 - (i) the pelvic body block illustrated in Figure 1 or, for a centre seating position, at the option of the manufacturer, the alternative pelvic body block illustrated in Figure 2 and
 - (ii) the upper torso body block illustrated in Figure 3,
 - (c) by applying and maintaining a force of 13 345 N simultaneously to each body block for 10 seconds in the direction in which the seat faces,

- (d) with the initial application angle of the force being not less than 5° and not more than 15° above the horizontal plane, and
- (e) with the onset rate of the force being not more than 133 447 N/s so as to attain the 13 345-N force in not more than 30 seconds.

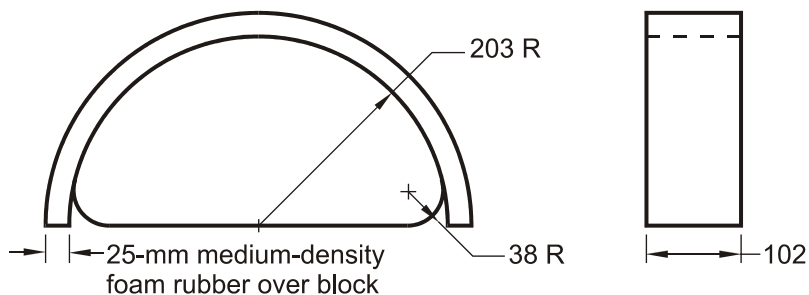

Note:

1. All dimensions are in mm with a tolerance of ± 1 .
2. Not to scale

Figure 3 — Body Block for a Combination Shoulder-and-Lap-Belt Anchorage

2.3 *Adjustment in the Case of Interference between the Pelvic Body Block and the Belt Buckle*

- 2.3.1 Place a 50th percentile adult male anthropomorphic test device (ATD) at each seating position and fasten the seat belt around it, removing all slack from the webbing. Place a mark on the seat belt webbing to indicate how far the seat belt extends from the retractor. Unbelt and remove the ATDs from the vehicle.
- 2.3.2 Place the body blocks against the back of the seat and fasten the seat belts around them. If, at this position, the belt buckle appears to be susceptible to damage from the test loads, move the body blocks forward, but not further than the mark made by following the procedure specified in subsection 2.3.1, in order to minimize the likelihood of buckle damage.