



Transport Canada
Safety and Security

Transports Canada
Sécurité et sûreté

Road Safety

Sécurité routière

Standards and Regulations Division

TEST METHOD 213.3

Restraint Systems for Disabled Persons

Revised: January 2007
Issued: June 1, 1987

Standards Research and Development Branch
Road Safety and Motor Vehicle Regulation Directorate
TRANSPORT CANADA
Ottawa, Ontario
K1A 0N5

TABLE OF CONTENTS

1. Introduction	1
2. Test Devices to be Used for the Dynamic Test for Production Restraint Systems and the Buckle Release Tests.....	1
3. Dynamic Tests for Production Restraint Systems	6
3.1 Test Acceleration.....	6
3.2 Test Conditions.....	7
3.3 Pre-Test Buckle Release Force Measurement.....	7
3.4 Positioning of the ATD and Installation of the Production Restraint System for the Dynamic Test Using the Seat Belt Assembly	7
3.5 Test Procedure.....	9
3.6 Positioning of the ATD and Installation of the Production Restraint System for the Dynamic Test Using the Lower Universal Anchorage System	9
3.7 Test Procedure.....	10
4. Buckle Release Test Procedure for Production Restraint Systems.....	11
5. Buckle Release Test Procedure for Custom-Made Restraint Systems.....	12
6. Energy Absorbing Material Test Procedure for All Restraint Systems.....	13
7. Flammability Test Procedure for All Restraint Systems	13
7.1 Test Devices	13
7.2 Test Conditions.....	15
7.3 Test Procedure.....	16
8. Webbing Test Procedures for All Restraint Systems	17
8.1 Measurement of the Width of the Webbing	17
8.2 Breaking Strength.....	17
8.3 Elongation	19
8.4 Resistance to Abrasion	19
8.5 Resistance to Light	20
8.6 Resistance to Micro-Organisms	21
8.7 Colourfastness to Staining.....	22
8.8 Colourfastness to Crocking	22

9. Seat Belt Assembly Hardware Test for All Restraint Systems	22
9.1 Conditioning Procedure.....	22
9.2 Corrosion Resistance	23
9.3 Temperature Resistance	23

TABLE OF FIGURES

Figure 1(a) – Three-dimensional Schematic View and Side View of the Standard Seat Assembly Indicating the Location of the Seat Belt Anchorage Points.....	2
Figure 1(b) – Three-dimensional Schematic View and Side View of the Standard Seat Assembly Indicating the Location of the Lower Universal Anchorage System	3
Figure 2 — Physical Dimensions and Masses of the ATDs.....	5
Figure 3 — Test Platform Acceleration Graph.....	6
Figure 4 — Webbing Tension Pull Device.....	8
Figure 5 — Self-Adjusting Sling for the Buckle Release Test.....	12
Figure 6 — Flammability Test Cabinet	14
Figure 7 — Thickness of the Test Specimen.....	16
Figure 8 — Split Drum Grips to be used in the Webbing Breaking Strength Tests	18
Figure 9 — Hexagonal Rod used for the Abrasion Test.....	19

LIST OF REFERENCED DOCUMENTS

Drawing Package NHTSA SAS-100-1000

Society of Automotive Engineers Recommended Practice J211,
Instrumentation for Impact Tests (October 1988)

American Society for Testing and Materials:

Standard Practice for Determination of Weight and Shape Changes of Plastics Under Accelerated Service Conditions, Designation No. D 756-93

Standard Practice for Operating Light-Exposure Apparatus (Carbon-Arc Type) With and Without Water for Exposure of Nonmetallic Materials, Designation No. G 23-96

Standard Practice for Operating Salt Spray (Fog) Testing Apparatus, Designation No. B 117-95

Standard Practices for Force Verification of Testing Machines, Designation No. E 4-96

Standard Specification for Flexible Cellular Materials—Sponge or Expanded Rubber, Designation No. D 1056-91

Standard Specification for Flexible Cellular Materials—Vinyl Chloride Polymers and Copolymers (Open-Cell Foam), Designation No. D 1565-81 (Reapproved 1990)

Standard Test Methods for Flexible Cellular Materials—Slab, Bonded, and Molded Urethane Foams, Designation No. D 3574-95

American Association of Textile Chemists and Colorists:

Evaluation Procedure 1, *Gray Scale for Color Change*

Test Method 30-1993, *Antifungal Activity, Assessment on Textile Materials: Mildew and Rot Resistance of Textile Materials*

Test Method 107-1991, *Colorfastness to Water*

Test Method 8-1996, *Colorfastness to Crocking: AATCC Crockmeter Method*

1. Introduction

Test Method 213.3 — Restraint Systems for Disabled Persons (January 2007) is to be used for demonstrating compliance with the requirements of Schedule 6 to the *Motor Vehicle Restraint Systems and Booster Cushions Safety Regulations* (RSSRs).

(Original signed by)

Director, Standards Research and Development
for the Minister of Transport,
Infrastructure and Communities
Ottawa, Ontario

2. Test Devices to be Used for the Dynamic Test for Production Restraint Systems and the Buckle Release Tests

- 2.1 The seat to be used for the dynamic test prescribed in this test method is the standard seat assembly, as described in Drawing Package NHTSA SAS-100-1000 and shown in Figure 1(a), which indicates the location of the seat belt anchorage points, and Figure 1(b), which indicates the location of the lower universal anchorage system, mounted on a dynamic test platform so that the Seat Orientation Reference Line (SORL) is parallel to the direction of travel of the test platform and so that movement between the base of the assembly and the platform is prevented.
- 2.2 The test platform must be instrumented with an accelerometer that is linked to a data processing system, and the accelerometer-sensitive axis must be parallel to the direction of travel of the test platform. The data must be filtered with a Class 60 filter, as specified in the Society of Automotive Engineers Recommended Practice J211, *Instrumentation for Impact Tests* (October 1988).

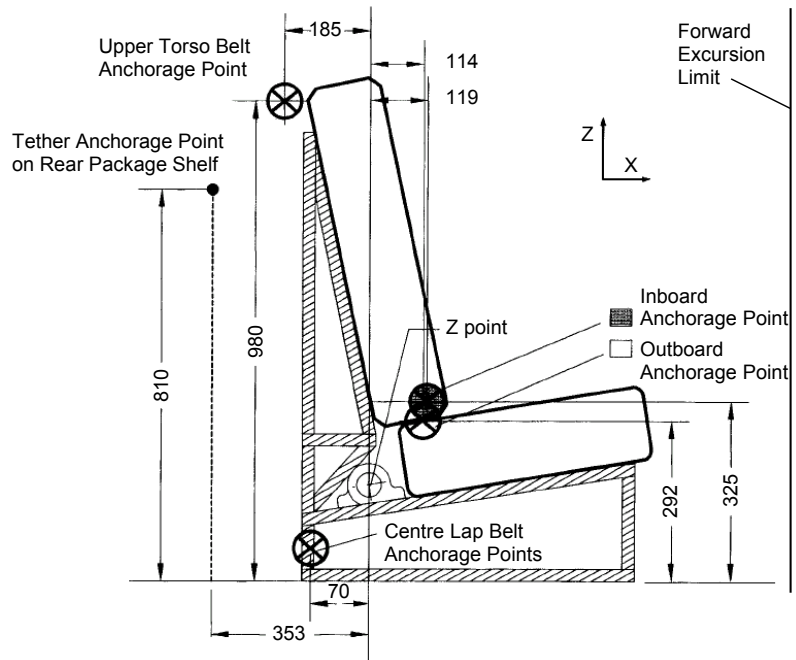
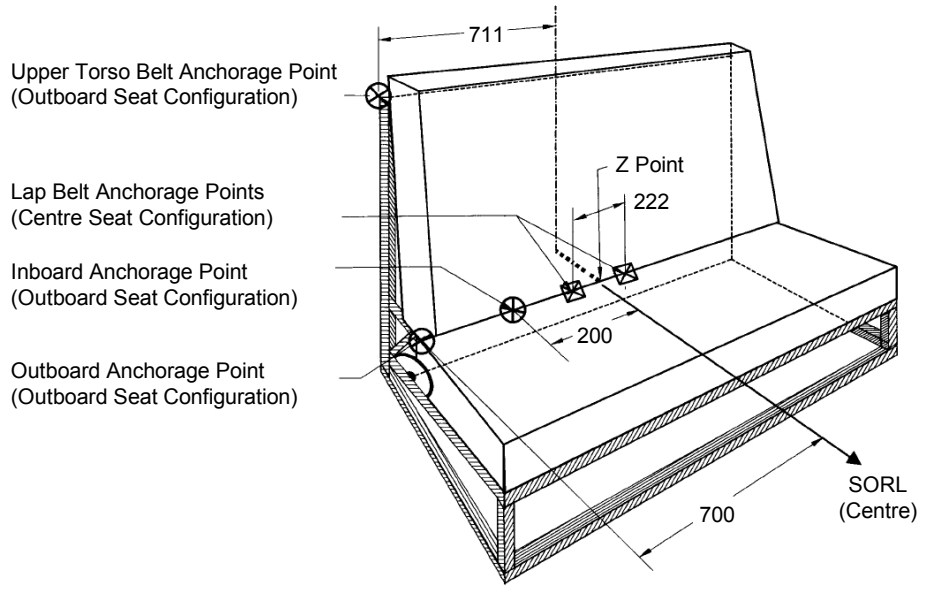

Notes:

1. Dimensions are in mm, except where otherwise indicated.
2. Drawings are not to scale.
3. Lap belt anchorage points are symmetrically located with respect to the centre SORL.
4. Maximum distance from the seat bight to the end of the buckle is 175 mm.
5. Outboard anchorage point is located 700 mm from the centre SORL.
6. Anchorage point on the rear package shelf is located on the vertical longitudinal plane containing the centre SORL.

Figure 1(a) — Three-dimensional Schematic View and Side View of the Standard Seat Assembly Indicating the Location of the Seat Belt Anchorage Points

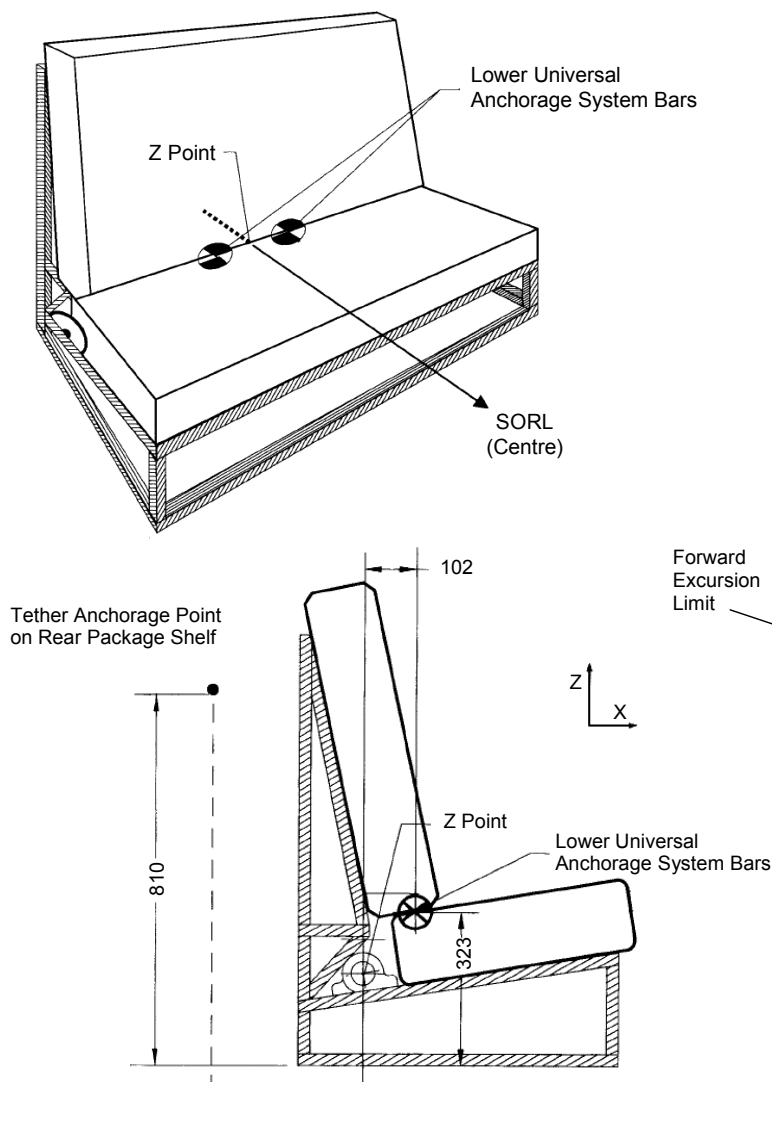

Notes:

1. Dimensions are in mm, except where otherwise indicated.
2. Drawings are not to scale.
3. Lower universal anchorage system bars are 6 mm in diameter and 25 mm in length.
4. Transverse horizontal distance between the centre of the bars and the vertical plane containing the SORL at the centre of the seat assembly is 140 mm.
5. Anchorage point on the rear package shelf is located on the vertical longitudinal plane containing the centre SORL.
6. Head excursion limit is 720 mm.
7. Lower universal anchorage system bars are located 102 mm forward of Z Point and 323 mm above the floor.

Figure 1(b) — Three-dimensional Schematic View and Side View of the Standard Seat Assembly Indicating the Location of the Lower Universal Anchorage System

- 2.3 Type 1 or Type 2 seat belt assemblies that meet the requirements of section 209 of the *Motor Vehicle Safety Regulations* and whose webbing is not more than 50 mm wide must be attached, without the use of retractors or reels of any kind, to the seat belt anchorage points provided on the standard seat assembly.
- 2.4 The anthropomorphic test device (ATD) to be used in the dynamic test and the buckle release tests must be of the appropriate height and mass for the system being tested, and it must conform to the dimensions and mass given in Figure 2 for that type of ATD. The ATD must be clothed in form-fitting cotton stretch underwear with short sleeves and mid-calf length pants. It must also wear sneakers with rubber soles and cotton or nylon uppers of the appropriate size.

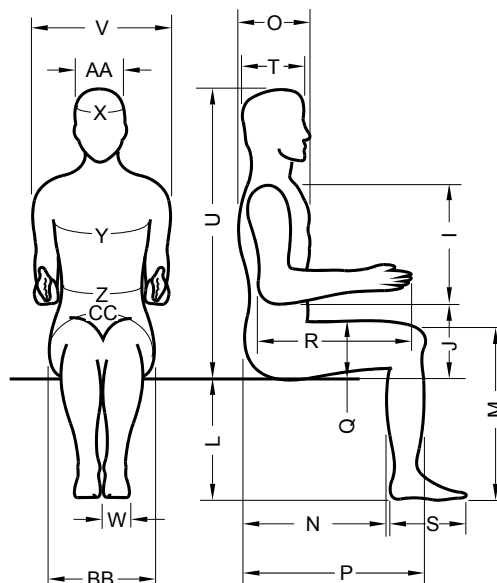

Symbol and Description	3-Year-Old Child ATD	6-Year-Old Child ATD	5 th Percentile Adult Female ATD	50 th Percentile Adult Male ATD
Standing height	973	1212	1499	1735
Mass in kg	15.1	21.5	46.3	74.7
I: Shoulder-elbow length	173	234	318	358
J: Elbow rest height	158	183	203	241
L: Popliteal height	-	325	373	439
M: Knee height (sitting)	264	368	447	544
N: Buttock-popliteal length	-	345	432	495
O: Chest depth	127	163	191	236
P: Buttock-knee height	325	406	531	592
Q: Thigh clearance	86	112	117	145
R: Elbow-fingertip length	254	320	401	475
S: Foot length	147	175	216	267
T: Head length	170	178	173	196
U: Sitting height (erect)	569	645	785	907
V: Shoulder breadth	236	264	381	455
W: Foot breadth	58	66	84	97
X: Head circumference	508	526	518	572
Y: Chest circumference	511	597	757	958
Z: Waist circumference (sitting)	-	528	599	838
AA: Head breadth (sitting)	137	150	137	154
BB: Hip breadth (sitting)	180	213	325	384
CC: Hip circumference (sitting)	-	607	925	1067

Note: The dimensions are in mm, unless otherwise specified.

Figure 2 — Physical Dimensions and Masses of the ATDs

3. Dynamic Tests for Production Restraint Systems

A first dynamic test is to be conducted in accordance with the procedure set out in subsections 3.4 and 3.5 using a new production restraint system for disabled persons that is attached to the standard seat assembly as shown in Figure 1(a) by the seat belt assembly and a tether strap, if one is provided with the system.

If the restraint system is equipped with a lower connector system, a second dynamic test is to be conducted in accordance with the procedure set out in subsections 3.6 and 3.7 using a new production restraint system for disabled persons that is attached to the standard seat assembly as shown in Figure 1(b) by the lower universal anchorage system and a tether strap, if one is provided with the system.

3.1 Test Acceleration

The dynamic tests simulate a frontal impact at 48 km/hr. At all points in time until 48 milliseconds after the start of the pulse, the acceleration of the test platform must be above that indicated by the line shown in Figure 3 and such that the total change of velocity is at least 48 km/h.

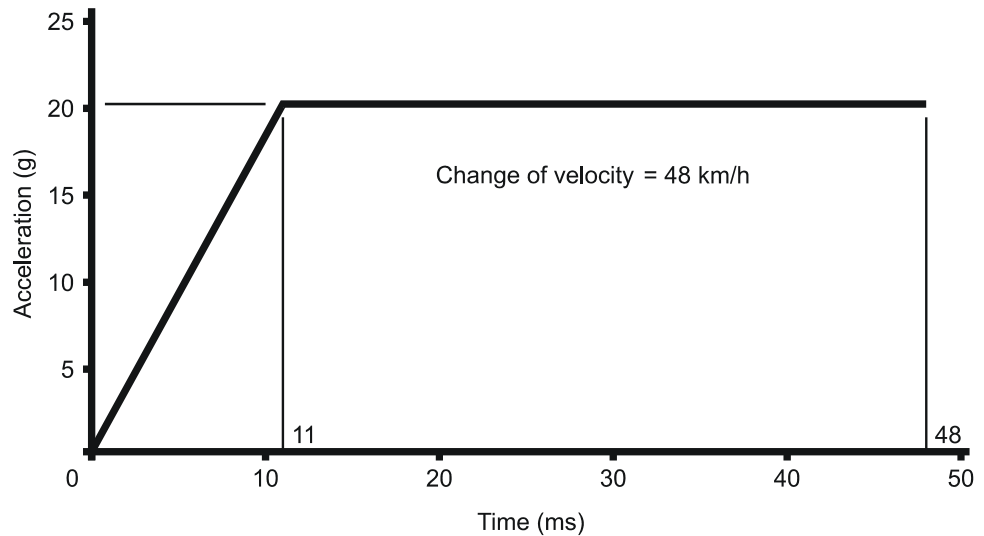

Figure 3 — Test Platform Acceleration Graph

3.2 Test Conditions

For the dynamic tests, the ambient temperature must be from 19°C to 26°C and the relative humidity from 10% to 70%.

3.3 Pre-Test Buckle Release Force Measurement

If the belts of the restraint system are equipped with buckles, the release force of each buckle is to be measured in the following manner before commencing the dynamic tests.

- 3.3.1 Place the buckle assembly on a hard, level surface.
- 3.3.2 Apply a pullout force of 9 N to the buckle assembly in a direction that will produce maximum releasing effect, in the case of
 - (a) A push-button-actuated buckle, on the centreline of the push-button opening of the buckle, or
 - (b) A lever-actuated buckle, at least 3 mm from the edge of the buckle lever or finger tab.
- 3.3.3 Measure the force required to release the buckle and determine its conformance to the requirements of Schedule 6 to the RSSRs.

3.4 Positioning of the ATD and Installation of the Production Restraint System for the Dynamic Test Using the Seat Belt Assembly

- 3.4.1 In accordance with the manufacturer's instructions, place a new production restraint system at the centre seating position of the standard seat assembly and position each movable surface. If the restraint system is installed by passing the motor vehicle seat belt over the system and under the seated ATD, attach the seat belt to the restraint system, but do not tighten it.
- 3.4.2 Place the ATD specified in subsection 2.4 in the restraint system and position it according to the manufacturer's instructions and as follows:
 - (a) Holding the torso upright until it contacts the seat back of the system, seat the ATD in the restraint system so that the mid-sagittal plane of its head is coincident with the SORL of the standard seating assembly.

- (b) Lift the arms of the ATD as far upward as possible. Extend the legs of the ATD as far forward horizontally as possible, with its feet perpendicular to the centreline of the lower legs.
- (c) Using a flat square surface with an area of $2\,580\text{ mm}^2$, apply a force of 180 N perpendicular to the plane of the back of the standard seat assembly, first against the crotch of the ATD and then against the mid-sagittal plane of its thorax.
- (d) Attach all the appropriate restraint system belts and harnesses and tighten them as specified in subsection 3.4.3.
- (e) Rotate each limb of the ATD downward in a plane parallel to its mid-sagittal plane until the limb touches a surface of the restraint system or the standard seat assembly. Position the limbs so that they will not inhibit the movement of the torso or head during the test.

3.4.3 If shoulder and pelvic belts are provided that directly restrain the ATD, they must be adjusted by tightening the belts until a 9-N force applied using a webbing tension pull device (as illustrated in Figure 4) to the webbing at the top of each shoulder and to the pelvic webbing 50 mm on either side of the mid-sagittal plane of the torso pulls the webbing a distance of 7 mm away from the ATD.

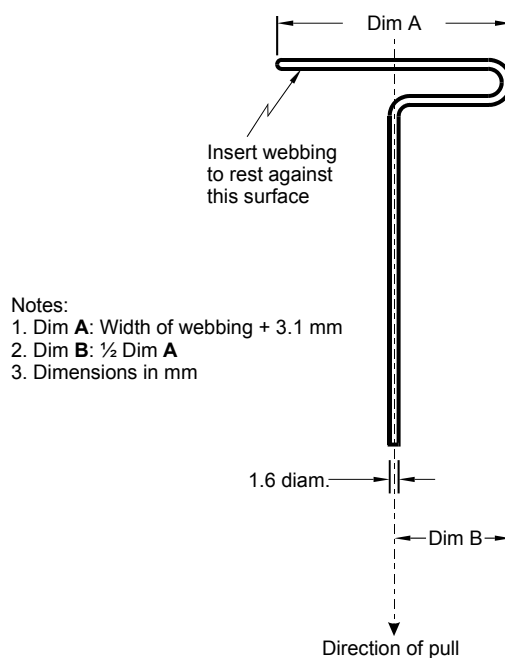

Figure 4 — Webbing Tension Pull Device

- 3.4.4 In accordance with the manufacturer's instructions, attach the production restraint system, if it is not already installed, to the standard seat assembly using the motor vehicle seat belt and attach the tether strap, if one has been provided. Tighten the seat belt and tether strap to a tension, as measured by a force gauge used on the webbing, of
- (a) until August 31, 2002, not less than 31 N and not more than 49 N or, at the option of the manufacturer, not less than 53.5 N and not more than 67 N; and
 - (b) on or after September 1, 2002, not less than 53.5 N and not more than 67 N.

3.5 Test Procedure

- 3.5.1 Accelerate the test platform in accordance with the requirements of subsection 3.1.
- 3.5.2 Measure the excursion of the ATD and determine the conformance of the restraint system to the requirements of section 12 of Schedule 6 to the RSSRs.

3.6 Positioning of the ATD and Installation of the Production Restraint System for the Dynamic Test Using the Lower Universal Anchorage System

- 3.6.1 In accordance with the manufacturer's instructions, place a new production restraint system at the centre seating position of the standard seat assembly and position each movable surface. As specified in subsection 3.6.4 and in accordance with the manufacturer's instructions, attach the lower connectors of the restraint system to the lower universal anchorage system and attach the tether strap, if one has been provided, to the standard seat assembly, but do not tighten it.
- 3.6.2 Place the ATD specified in subsection 2.4 in the restraint system and position it according to the manufacturer's instructions and as follows:
- (a) Holding the torso upright until it contacts the seat back of the system, seat the ATD in the restraint system so that the mid-sagittal plane of its head is coincident with the SORL of the standard seating assembly.

- (b) Lift the arms of the ATD as far upward as possible. Extend the legs of the ATD as far forward horizontally as possible, with its feet perpendicular to the centreline of the lower legs.
- (c) Using a flat square surface with an area of 2 580 mm², apply a force of 180 N perpendicular to the plane of the back of the standard seat assembly, first against the crotch of the ATD and then against the mid-sagittal plane of its thorax.
- (d) Attach all the appropriate belts and harnesses on the restraint system and tighten them as specified in subsection 3.6.3.
- (e) Rotate each limb of the ATD downward in a plane parallel to its mid-sagittal plane until the limb touches a surface of the restraint system or the standard seat assembly. Position the limbs so that they will not inhibit the movement of the torso or head during the test.

3.6.3 If shoulder and pelvic belts are provided that directly restrain the ATD, they must be adjusted by tightening the belts until a 9-N force applied using a webbing tension pull device (as illustrated in figure 4) to the webbing at the top of each shoulder and to the pelvic webbing 50 mm on either side of the mid-sagittal plane of the torso pulls the webbing a distance of 7 mm away from the ATD.

- 3.6.4 (a) Adjust rigid lower connectors in accordance with the manufacturer's instructions;
- (b) If a tether strap has been provided, tighten it to a tension of not less than 53.5 N and not more than 67 N, as measured by a force gauge used on the webbing.

3.7 Test Procedure

- 3.7.1 Accelerate the test platform in accordance with the requirements of subsection 3.1.
- 3.7.2 Measure the excursion of the ATD and determine the conformance of the restraint system to the requirements of paragraph 12(1)(d) of Schedule 6 to the RSSRs.

4. Buckle Release Test Procedure for Production Restraint Systems

- 4.1 The release force of each buckle is to be tested with the ATD specified in subsection 2.4 of this test method retained in the restraint system.
- 4.2 The buckle release force is to be tested as follows:
- (a) Tie a self-adjusting sling to the wrists and ankles of the ATD, as illustrated in Figure 5.
 - (b) While applying a pullout force of 9 N to the buckle assembly in a direction that will produce maximum releasing effect, pull the sling horizontally and parallel to the SORL of the standard seat assembly with a force of 200 N.

Note: If the restraint system is equipped with a T-shield, a force equivalent to its mass must be added to the pullout force. Any shield, if present, may be adjusted to facilitate application of the pullout force, provided that the harness tension is not significantly affected.
 - (c) In order to determine the buckle's conformance to the requirements of Schedule 6 to the RSSRs, apply the specified force in a direction that will produce maximum releasing effect, in the case of
 - (i) A push-button-actuated buckle, on the centreline of the push-button opening, or
 - (ii) A lever-actuated buckle, at least 3 mm from the edge of the buckle lever or finger tab.
 - (d) If the force required to release the buckle exceeds the requirements of Schedule 6 to the RSSRs, release the harness tension and apply a force of 22 to 44 N to the lowest accessible part of the tongue 2 to 4 times in each of four directions at 90-degree angles to each other.
 - (e) Repeat paragraphs (b) and (c) above while applying a pullout force on the buckle assembly of 22 N, re-orienting the direction of the sling pull force if necessary so that the arms of the ATD do not load the shield.
 - (f) If the buckle does not release at the force specified in Schedule 6 to the RSSRs, repeat paragraphs (b) and (c) once again using a pullout force of 44 N.

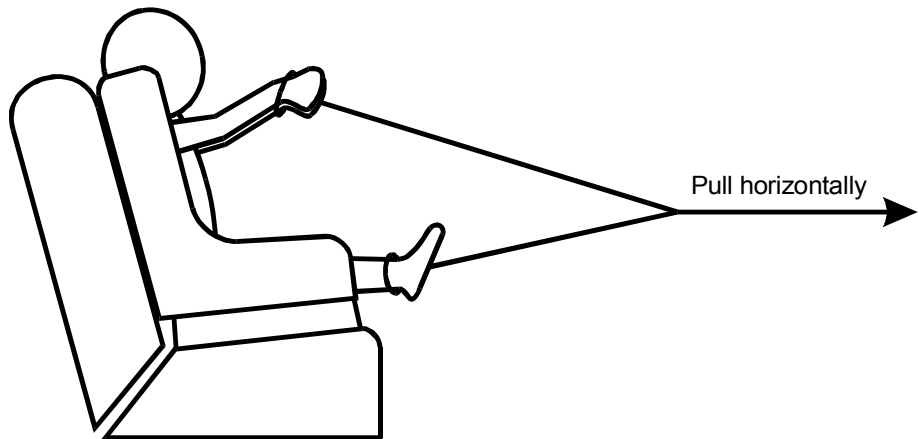

Figure 5 — Self-Adjusting Sling for the Buckle Release Test

5. Buckle Release Test Procedure for Custom-Made Restraint Systems

- 5.1 The seat belt assembly must be subject to a force on the components of the buckle of either:
- (a) 333 N when the maximum recommended mass of the occupant is 22 kg or more, or
 - (b) 200 N when the maximum recommended mass of the occupant is less than 22 kg.
- 5.2 The buckle release force must be applied in a manner and direction typical of those encountered in use.
- 5.3 For push-button-actuated buckles, the force must be applied on the centreline of the push-button opening in a direction that produces maximum releasing effect. For lever-actuated buckles, the force must be applied at least 3 mm from the edge of the buckle lever or finger tab in a direction that produces maximum releasing effect.
- 5.4 For push-button-actuated buckles, the area to which the release force is applied must be determined to the nearest 32 mm². For lever-actuated buckles, a cylinder 10 mm in diameter and 38 mm in length must be inserted into the actuation portion of the buckle in order to determine its conformance with the requirements of

subsection 5.1. Buckles with other release actuation mechanisms must be examined to ensure that the fingers can be inserted.

- 5.5 The belt buckle must be subjected to a compressive force of 1 780 N applied anywhere on a test line that coincides with the centreline of the belt when it is extended through the buckle or on any line that extends over the centre of the release mechanism. The latter line must intersect with the extended centreline of the belt at an angle of 60°. The load must be applied by using a curved cylindrical bar having a cross-sectional diameter of 19 mm and a radius of curvature of 150 mm, placed with its longitudinal centreline along the test line and its centre directly above the point on the buckle to which the load will be applied. The buckle must be latched, and a tensile force of 333 N must be applied to the connected webbing during the application of the compressive force.

6. Energy Absorbing Material Test Procedure for All Restraint Systems

- 6.1 Prepare and test specimens of energy absorbing material in accordance with the applicable 25% compression-deflection test specified in one of the following American Society for Testing and Materials (ASTM) Standards:
- *Standard Specification for Flexible Cellular Materials—Sponge or Expanded Rubber*, Designation No. D 1056-91;
 - *Standard Specification for Flexible Cellular Materials—Vinyl Chloride Polymers and Copolymers (Open-Cell Foam)*, Designation No. D 1565-81 (Reapproved 1990); or
 - *Standard Test Methods for Flexible Cellular Materials—Slab, Bonded, and Molded Urethane Foams*, Designation No. D 3574-95.
- 6.2 Determine the conformance of the test specimens to the requirements of section 5 of Schedule 6 to the RSSRs.

7. Flammability Test Procedure for All Restraint Systems

7.1 Test Devices

- 7.1.1 **Flammability Test Cabinet:** In order to protect the test specimens from drafts, the flammability test must be conducted in a cabinet constructed in accordance with the following specifications and as

illustrated in Figure 6. The flammability test cabinet must be constructed of metal and must have:

- (a) an interior length of 381 mm, a depth of 203 mm, and a height of 356 mm;
- (b) a glass observation window in the front;
- (c) a closeable opening to permit the insertion of a specimen holder;
- (d) a hole to accommodate tubing for a bunsen burner; and
- (e) for ventilation, a clearance space of 13 mm around the top of the cabinet, ten holes 19 mm in diameter in the base of the cabinet, and legs that elevate the cabinet by 10 mm.

7.1.2 **Specimen holder:** The test specimen must be mounted between two U-shaped frames of metal stock 25 mm wide and 10 mm high. The dimensions of the interior U of each frame must be 51 mm by 330 mm.

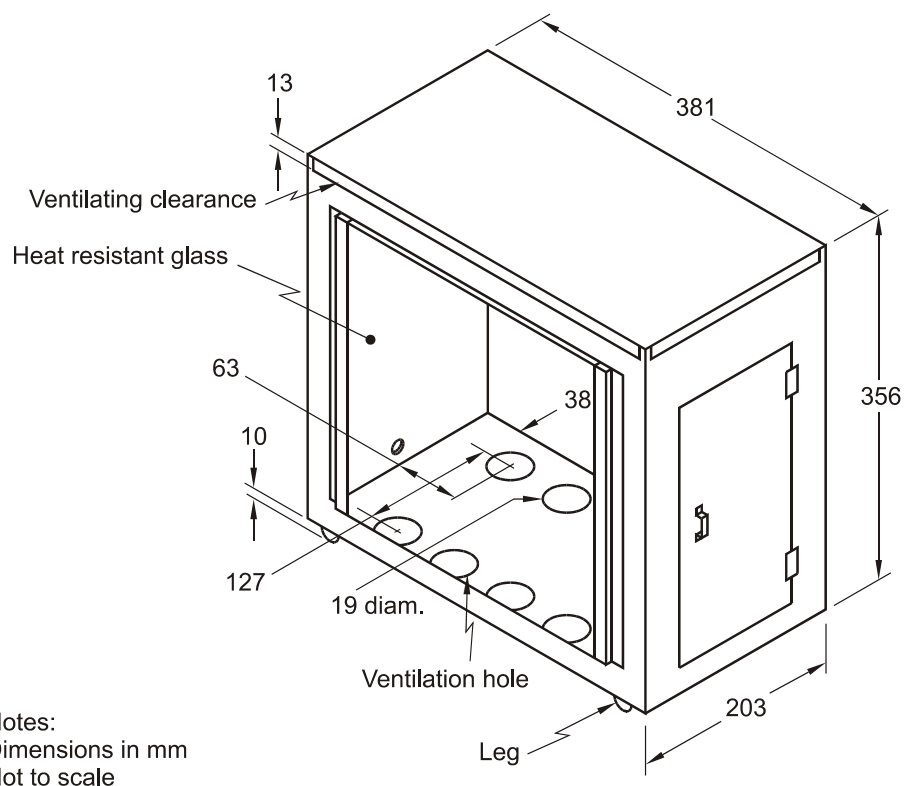

Figure 6 — Flammability Test Cabinet

- 7.1.3 A specimen that softens and bends at the flaming end in a manner that causes erratic burning must be kept horizontal by using either of the following inserted along the length of the bottom frame under the specimen:
- (a) supports consisting of thin, heat-resistant wires distributed at 25-mm intervals or
 - (b) an additional U-shaped frame that is wider than the specimen holder with heat-resistant wires 254 μm in diameter, distributed at 25-mm intervals.

7.2 *Test Conditions*

- 7.2.1 Prior to testing, each specimen must be conditioned for 24 hours at a temperature of 21°C and a relative humidity of 50%. The test must be conducted under these ambient conditions.
- 7.2.2 A bunsen burner with an interior diameter of 10 mm must be used for the test. With the air inlet to the burner closed and the burner vertical, the gas adjusting valve must be set to provide a flame 38 mm in height. The flame temperature must be equivalent to that of natural gas.
- 7.2.3 The test specimen must be rectangular in shape and 102 mm wide by 356 mm long, whenever possible. The thickness of the specimen must be that of the single or composite material used for the restraint system, except under the following circumstances:
- (a) where the material does not adhere to another material at every point of contact, it must be tested separately;
 - (b) where the material adheres to another material at every point of contact, it must be tested as a composite with the other material;
 - (c) if the thickness of the material exceeds 13 mm, the specimen must be cut down to that thickness, as measured from the inner surface of the specimen (see Figure 7);
 - (d) where a flat specimen cannot be obtained because of surface curvature, it must be cut to 13 mm or less in thickness; and
 - (e) the maximum available length and width of a specimen must be used where either dimension is less than 356 mm and 102 mm, respectively.

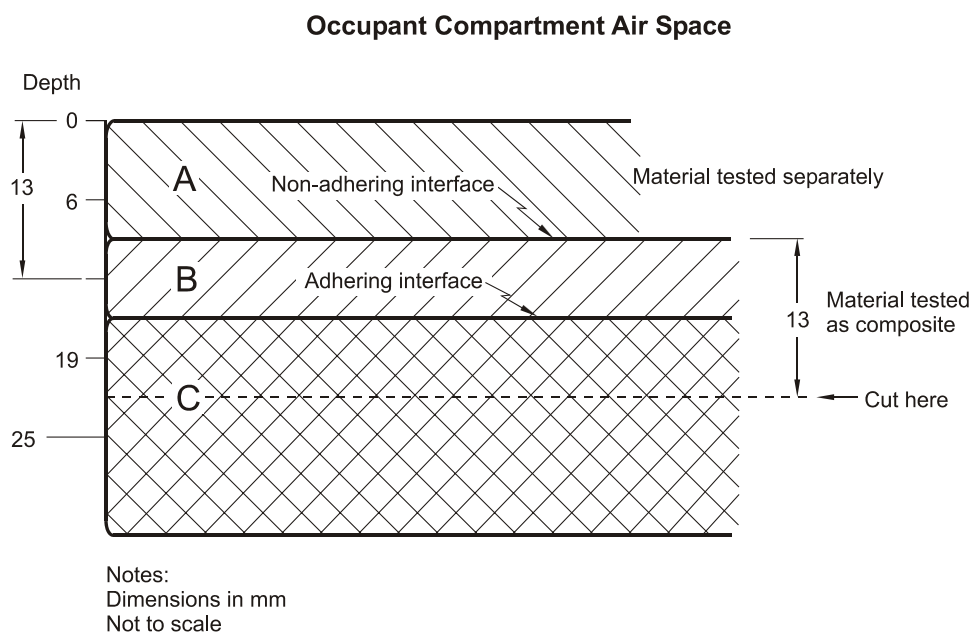

Figure 7 — Thickness of the Test Specimen

7.2.4 The material for the specimen must be cut in the direction that will produce the most adverse test results, and it must be positioned so that the inner surface faces downward on the test frame.

7.2.5 Prior to testing, napped or tufted material must be placed on a flat surface and combed twice against the nap with a comb that has seven or eight smooth, rounded teeth per 25 mm.

7.3 Test Procedure

7.3.1 Subject to subsection 7.3.2, the specimen must be mounted so that both sides and one end are anchored between the U-shaped frames and the free end is even with the edge of the specimen holder.

7.3.2 Where the specimen is less than 51 mm wide and cannot be mounted properly in the specimen holder, the specimen must be placed on wire supports, as specified in subsection 7.1.3, with one side anchored in the short end of the U-shaped frames.

7.3.3 The mounted specimen must be placed in a horizontal position in the centre of the cabinet.

7.3.4 With the flame adjusted as specified in subsection 7.2.2, the bunsen burner must be positioned with the tip of the flame 19 mm below the centre of the free end of the specimen.

- 7.3.5 The specimen must be exposed to the flame for 15 seconds.
- 7.3.6 For the purpose of calculating the burn rate below, the timing must begin only once the flame from the burning specimen has progressed a distance of 38 mm.
- 7.3.7 The time it takes for the flame to travel to a point 38 mm from the clamped end of the specimen must be measured. If the flame goes out before reaching the specified point, the timing must stop when the flame goes out.
- 7.3.8 The burn rate must be calculated using the following formula:

$$B = 60 \cdot \frac{D}{T}$$

where: B = Burn rate in mm per minute,
D = Distance the flame travels in mm, and
T = Time in seconds for the flame to travel
D mm.

- 7.3.9 The requirement contained in subsection 11(1) of Schedule 6 to the RSSRs, which concerns the transmission of a flame front across the surface of a restraint system, does not apply to this flammability test.

8. Webbing Test Procedures for All Restraint Systems

8.1 *Measurement of the Width of the Webbing*

- 8.1.1 Before being measured, the seat belt and tether strap webbing of the restraint system must be conditioned for at least 24 hours at a temperature of 23°C ± 2°C and a relative humidity of between 48% and 67%.
- 8.1.2 During the measurement of its width, the tension at every point along the webbing must be no more than 22 N.
- 8.1.3 The width measurements must be made using properly calibrated calipers with sufficient adjustment.

8.2 *Breaking Strength*

- 8.2.1 The webbing of the seat belt and tether strap must be conditioned as specified in subsection 8.1.1.

- 8.2.2 The breaking strength of the webbing must be measured using a testing machine of suitable capacity verified as having an error of no more than 1% in the range of the breaking strength. The webbing must be tested in accordance with ASTM *Standard Practices for Force Verification of Testing Machines*, Designation No. E 4-96.
- 8.2.3 The testing machine must be equipped with split drum grips, as illustrated in Figure 8, having a diameter of between 50 mm and 100 mm. The rate of grip separation must be between 50 and 100 mm per minute. The distance between the centres of the grips at the start of the test must be between 100 mm and 250 mm. After placing the test specimen in the grips, the webbing must be stretched continuously at a uniform rate to failure.
- 8.2.4 The value obtained for the breaking strength of the webbing must be used for determining the retained breaking strength, as required by subsections 8.4, 8.5, and 8.6.

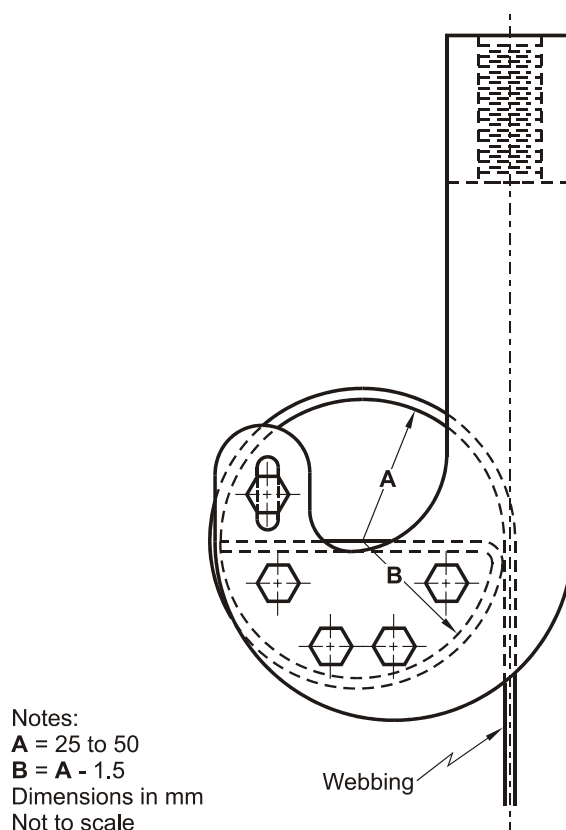

Figure 8 — Split Drum Grips to be used in the Webbing Breaking Strength Tests

8.3 Elongation

8.3.1 Elongation must be measured during the breaking strength test specified in subsection 8.2 using the following procedure:

- (a) A preload of between 196 N and 245 N must be placed on the webbing mounted in the grips of the testing machine, and the needle points of an extensometer, in which the points remain parallel during testing, must be inserted into the centre of the specimen. Initially, the points must be set between 100 mm and 200 mm apart, and
- (b) When the force on the webbing reaches the applicable value specified in paragraph 9(g) of Schedule 6 to the RSSRs, the increase in separation of the points of the extensometer must be measured and the percent elongation must be calculated to the nearest 0.5%.

8.4 Resistance to Abrasion

8.4.1 The webbing of the restraint system must be tested for resistance to abrasion by rubbing a test specimen over a hexagonal rod, as illustrated in Figure 9.

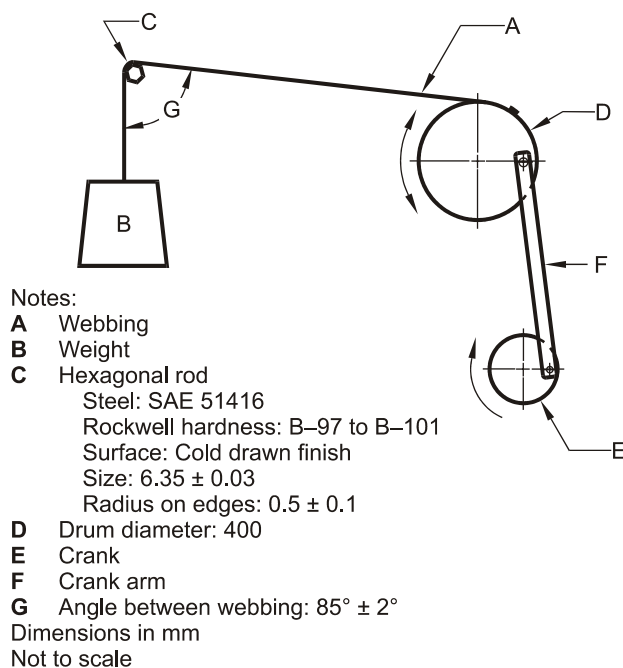

Figure 9 — Hexagonal Rod used for the Abrasion Test

- 8.4.2 One end of the webbing (A) must be attached to the weight (B), which must have a mass of either:
- (a) 2.35 kg ± 0.05 kg for the webbing of a restraint system for which the maximum recommended mass of the occupant is 22 kg or more, or
 - (b) 1.50 kg ± 0.05 kg where the maximum recommended mass of the occupant is less than 22 kg.
- 8.4.3 The webbing must be passed over two unused abrading edges of the hexagonal rod (C) and the other end attached to an oscillating drum (D) that has a stroke of 330 mm. Guides must be used to prevent the webbing from moving along the axis of the hexagonal rod. The drum must be oscillated for 5 000 strokes or 2 500 cycles, at a rate of 60 ± 2 strokes per minute or 30 ± 1 cycles per minute.
- 8.4.4 The abraded webbing must be conditioned as specified in subsection 8.1.1 and tested for breaking strength in accordance with the procedure specified in subsections 8.2.2 and 8.2.3.
- 8.4.5 The percentage of the retained breaking strength for the abraded webbing (RBS) must be calculated as follows:

$$RBS = \frac{BS_{abraded}}{BS_{unabraded}} \times 100\%$$

where: $BS_{abraded}$ = is the breaking strength value of the abraded webbing, and
 $BS_{unabraded}$ = is the breaking strength value of the unabraded webbing obtained in accordance with the requirements of subsection 8.2.

8.5 *Resistance to Light*

- 8.5.1 A strip of webbing at least 500 mm in length must be suspended vertically on the inside of the specimen rack in a Type E carbon-arc light-exposure apparatus as specified in ASTM *Standard Practice for Operating Light-Exposure Apparatus (Carbon-Arc Type) With and Without Water for Exposure of Nonmetallic Materials*, Designation No. G 23-96, except that the filter used for 100% polyester yarns must be chemically strengthened by soda-lime glass with a transmittance of less than 5%, for wave lengths

less than or equal to 305 nm, or with a transmittance of 90% or more, for wave lengths from 375 nm to 800 nm.

- 8.5.2 The light exposure apparatus must be operated without water spray at an air temperature of $60^{\circ}\text{C} \pm 2^{\circ}\text{C}$, as measured at a point 25 mm \pm 5 mm outside the specimen rack and midway in height. The temperature sensing element must be shielded from radiation.
- 8.5.3 The test specimen must be exposed to the light from the carbon arc for 100 hours and then conditioned as specified in subsection 8.1.1.
- 8.5.4 The colourfastness of the exposed and conditioned specimen must be determined using Evaluation Procedure 1, *Gray Scale for Color Change*, published by the American Association of Textile Chemists and Colorists (AATCC). The breaking strength of the specimen must be determined using the procedure specified in subsections 8.2.2 and 8.2.3.
- 8.5.5 The percentage of the retained breaking strength for the exposed webbing (RBS) must be calculated as follows:

$$RBS = \frac{BS_{\text{exposed}}}{BS_{\text{unexposed}}} \times 100\%$$

where: BS_{exposed} = is the breaking strength value of the exposed webbing, and
 $BS_{\text{unexposed}}$ = is the breaking strength value of the unexposed webbing obtained in accordance with the requirements of subsection 8.2.

8.6 Resistance to Micro-Organisms

- 8.6.1 A strip of webbing at least 500 mm in length must be preconditioned in accordance with the requirements of Appendices A(1) and (2) of AATCC Test Method 30-1993, *Antifungal Activity, Assessment on Textile Materials: Mildew and Rot Resistance of Textile Materials*, and then subject to Test I, "Soil Burial", of that test method.
- 8.6.2 The breaking strength of the tested specimen must be determined by the procedure specified in subsections 8.2.2 and 8.2.3.

- 8.6.3 The percentage of the retained breaking strength for the exposed webbing (RBS) must be calculated as follows:

$$RBS = \frac{BS_{exposed}}{BS_{unexposed}} \times 100\%$$

where: $BS_{exposed}$ = is the breaking strength value of the exposed webbing, and
 $BS_{unexposed}$ = is the breaking strength value of the unexposed webbing obtained in accordance with the requirements of subsection 8.2.

8.7 *Colourfastness to Staining*

- 8.7.1 The webbing must be tested for colourfastness to staining using the procedure specified in AATCC Test Method 107–1991, *Colorfastness to Water*, except that the following must be used in the testing:

- (1) distilled water,
- (2) the AATCC perspiration tester,
- (3) a drying time of four hours for section 8.4 of the AATCC test method, and
- (4) section 9 of the above AATCC test method when determining the colourfastness to staining based on the AATCC *Chromatic Transference Scale*.

8.8 *Colourfastness to Crocking*

- 8.8.1 The webbing must be tested using the procedure specified in AATCC Test Method 8-1996, *Colorfastness to Crocking: AATCC Crockmeter Method*.

9. **Seat Belt Assembly Hardware Test for All Restraint Systems**

9.1 *Conditioning Procedure*

During conditioning, the buckles must be unlatched, and the same conditioned hardware parts must be used for the tests specified in subsections 8(3) and 8(4) of Schedule 6 to the RSSRs.

9.2 Corrosion Resistance

- 9.2.1 The seat belt assembly must be tested using ASTM *Standard Practice for Operating Salt Spray (Fog) Testing Apparatus*, Designation No. B 117-95. Any temporary surface coating or material must be removed from the specimen before testing. The test period for all hardware must be 25 hours in duration and consist of one 24-hour period of exposure to salt spray, followed by 1 hour of drying time.
- 9.2.2 The seat belt assembly must be positioned in the salt spray test chamber in such a way that corrosion is most likely to develop on the larger surfaces. At the end of the test, the seat belt assembly must be washed thoroughly with water to remove the salt.
- 9.2.3 After drying the test specimen for at least 24 hours under the laboratory conditions specified in subsection 8.1.1 of this test method, the attachment hardware must be examined for ferrous corrosion on all the surfaces that can be contacted by a sphere 19 mm in diameter. The other hardware must be examined for any ferrous or non-ferrous corrosion that could be transferred, either directly or by means of the webbing, to an occupant or to an occupant's clothing by the seat belt assembly.

9.3 Temperature Resistance

A seat belt assembly with plastic or non-metallic hardware must be tested in accordance with the conditions specified in Procedure D of ASTM *Standard Practice for Determination of Weight and Shape Changes of Plastics Under Accelerated Service Conditions*, Designation No. D 756-93. The dimension and weight measurements are not required.