



Transport Canada
Safety and Security

Transports Canada
Sécurité et sûreté

Road Safety

Sécurité routière

Standards and Regulations Division

TEST METHOD 213.5

Restraint Systems for Infants with Special Needs

Revised: October 2001

Issued: October 1997

Standards Research and Development Branch
Road Safety and Motor Vehicle Regulation Directorate
TRANSPORT CANADA
Ottawa, Ontario
K1A 0N5

TABLE OF CONTENTS

| | |
|---|-----------|
| 1. Introduction | 1 |
| 2. Test Devices to be Used for the Dynamic Test and the Buckle Release Test | 1 |
| 3. Dynamic Tests | 5 |
| 3.1 Test Acceleration | 5 |
| 3.2 Test Conditions | 6 |
| 3.3 Pre-Test Buckle Release Force Measurement | 6 |
| 3.4 Positioning of the ATD and Installation of the Restraint System for the Dynamic Test Using the Seat Belt Assembly | 7 |
| 3.5 Test Procedure | 8 |
| 3.6 Positioning of the ATD and Installation of the Restraint System for the Dynamic Test Using the Lower Universal Anchorage System | 9 |
| 3.7 Test Procedure | 10 |
| 3.8 Infant Restraint Systems with a Separate Base..... | 10 |
| 4. Buckle Release Test Procedure..... | 10 |
| 5. Energy Absorbing Material Test Procedure | 13 |

TABLE OF FIGURES

| | |
|--|----|
| Figure 1(a) — Three-dimensional Schematic View and Side View of the Standard Seat Assembly Indicating the Location of the Seat Belt Anchorage Points..... | 2 |
| Figure 1(b) — Three-dimensional Schematic View and Side View of the Standard Seat Assembly Indicating the Location of the Lower Universal Anchorage System | 3 |
| Figure 2 — Test Platform Acceleration Graph..... | 6 |
| Figure 3 — Webbing Tension Pull Device..... | 8 |
| Figure 4 — Self-Adjusting Sling for the Buckle Release Test for Restraint Systems that Are Not Car Beds | 12 |
| Figure 5 — Self-Adjusting Sling for the Buckle Release Test for Car Beds .. | 12 |

LIST OF REFERENCED DOCUMENTS

Drawing Package NHTSA SAS-100-1000

Society of Automotive Engineers Recommended Practice J211,
Instrumentation for Impact Tests (October 1988)

Code of Federal Regulations (October 1, 1996), Title 49, Part 572,
Subparts D, J, and K

American Society for Testing and Materials:

*Standard Specification for Flexible Cellular Materials—Sponge or
Expanded Rubber*, Designation No. D 1056-91

*Standard Specification for Flexible Cellular Materials—Vinyl
Chloride Polymers and Copolymers (Open-Cell Foam)*, Designation
No. D 1565-81 (Reapproved 1990)

*Standard Test Methods for Flexible Cellular Materials—Slab,
Bonded, and Molded Urethane Foams*, Designation No. D 3574-95

1. Introduction

Test Method 213.5 — Restraint Systems for Infants with Special Needs (October 2001) is to be used for demonstrating compliance with the requirements of Schedule 7 to the *Motor Vehicle Restraint Systems and Booster Cushions Safety Regulations* (RSSRs).

(Original signed by)

Director, Standards Research and Development
for the Minister of Transport
Ottawa, Ontario

2. Test Devices to be Used for the Dynamic Test and the Buckle Release Test

- 2.1 The seat to be used for the dynamic test prescribed in this test method is the standard seat assembly, as described in Drawing Package NHTSA SAS-100-1000 and shown in Figure 1(a), which indicates the location of the seat belt anchorage points, and Figure 1(b), which indicates the location of the lower universal anchorage system, mounted on a dynamic test platform so that the Seat Orientation Reference Line (SORL) is parallel to the direction of travel of the test platform and so that movement between the base of the assembly and the platform is prevented.
- 2.2 The test platform must be instrumented with an accelerometer that is linked to a data processing system, and the accelerometer-sensitive axis must be parallel to the direction of travel of the test platform. The data must be filtered with a Class 60 filter, as specified in the Society of Automotive Engineers Recommended Practice (SAE) J211, *Instrumentation for Impact Tests* (October 1988).

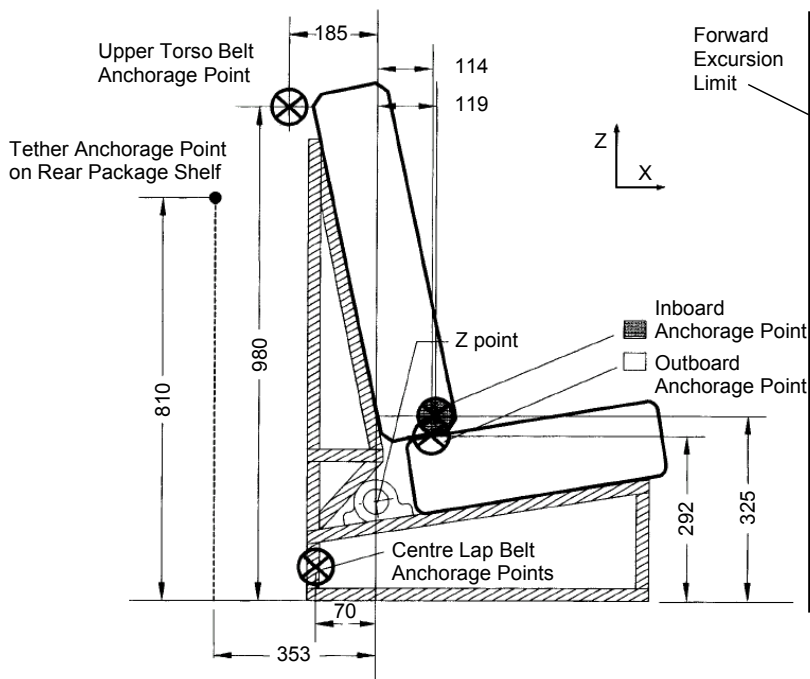
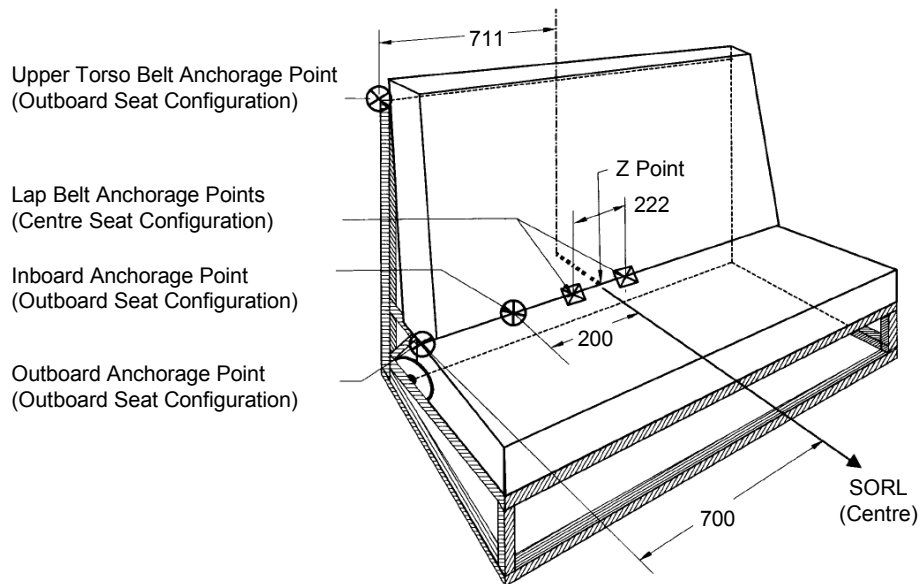

Notes:

1. Dimensions are in mm, except where otherwise indicated.
2. Drawings are not to scale.
3. Lap belt anchorage points are symmetrically located with respect to the centre SORL.
4. Maximum distance from the seat bight to the end of the buckle is 175 mm.
5. Outboard anchorage point is located 700 mm from the centre SORL.
6. Anchorage point on the rear package shelf is located on the vertical longitudinal plane containing the centre SORL.

Figure 1(a) — Three-dimensional Schematic View and Side View of the Standard Seat Assembly Indicating the Location of the Seat Belt Anchorage Points

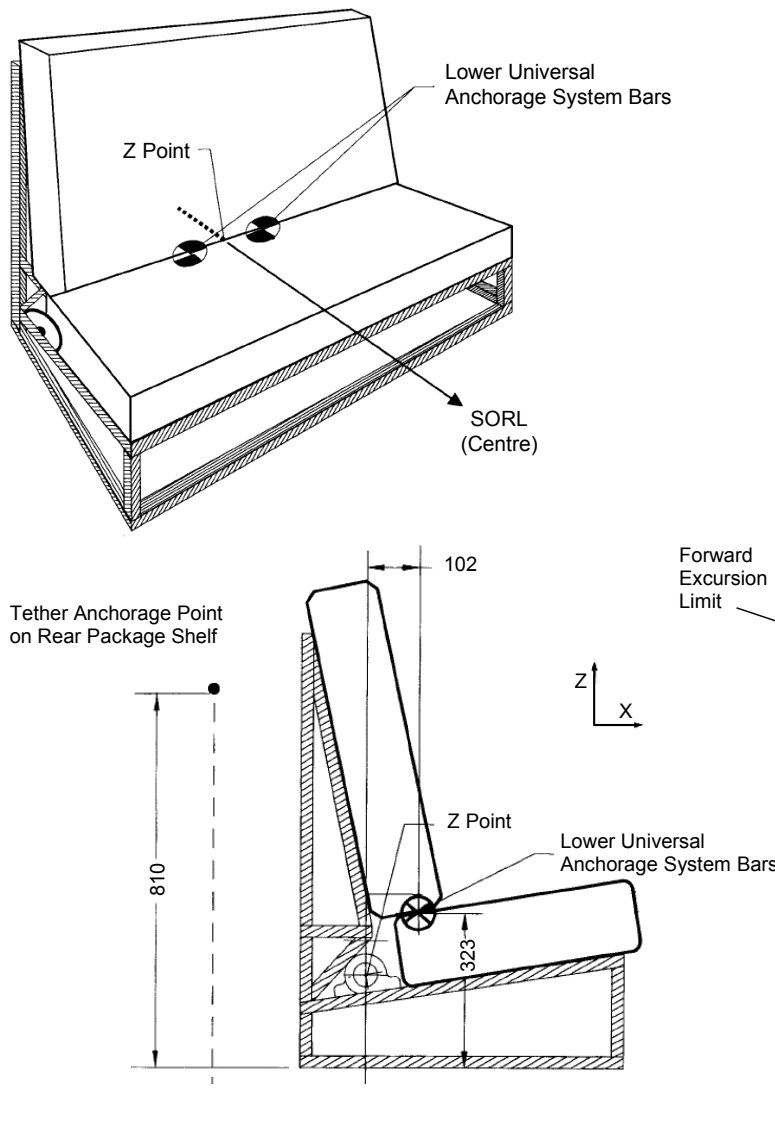

Notes:

1. Dimensions are in mm, except where otherwise indicated.
2. Drawings are not to scale.
3. Lower universal anchorage system bars are 6 mm in diameter and 25 mm in length.
4. Transverse horizontal distance between the centre of the bars and the vertical plane containing the SORL at the centre of the seat assembly is 140 mm.
5. Anchorage point on the rear package shelf is located on the vertical longitudinal plane containing the centre SORL.
6. Head excursion limit is 720 mm.
7. Lower universal anchorage system bars are located 102 mm forward of Z Point and 323 mm above the floor.

Figure 1(b) — Three-dimensional Schematic View and Side View of the Standard Seat Assembly Indicating the Location of the Lower Universal Anchorage System

2.3 A Type 1 seat belt assembly that meets the requirements of section 209 of the *Motor Vehicle Safety Regulations* and whose webbing is not more than 50 mm wide must be attached, without the use of retractors or reels of any kind, to the seat belt anchorage points provided on the standard seat assembly.

2.4 Two dynamic tests must be performed using the following anthropomorphic test devices (ATD):

- (a) The ATD used in one of the tests must be an unclothed ATD that represents a premature infant, referred to as a “Premie”, that has the following characteristics:

| | |
|---------------------------------|--|
| Height | 477 mm |
| Mass | 2.041 kg |
| Head circumference | 330 mm |
| Top of head to shoulder | 147 mm |
| Neck circumference | 152 mm |
| Shoulders to heels | 330 mm |
| Chest circumference | 330 mm |
| Waist circumference | 330 mm |
| Upper arm circumference | 102 mm |
| Lower arm circumference | 76 mm |
| Leg at hip circumference | 137 mm |
| Leg at knee circumference | 102 mm |
| Leg at ankle circumference | 79 mm |
| Arm length (arm to tip of hand) | 135 mm |
| Leg length (crotch to heel) | 152 mm |
| Under foot length | 41 mm |
| Centre of gravity | 59% of height from under foot |
| Covering material | lightweight soft 100% cotton denim 198 to 283 g/m ² |
| Filling | polyurethane batting |
| Ballast weights | lead sinker fishing weights covered in plastic to prevent shifting |

- (b) The ATD used in the other test must be one of the following:
- (i) if the restraint system is recommended for use by an infant with a mass no greater than 5 kg, an unclothed newborn infant ATD that conforms to the requirements of the U.S. *Code of Federal Regulations* (October 1, 1996), Title 49, Part 572, Subpart K;
 - (ii) if the restraint system is recommended for use by an infant with a mass no greater than 7.7 kg, an unclothed 6-month-old infant ATD that conforms to the requirements of the U.S. *Code of Federal Regulations* (October 1, 1996), Title 49, Part 572, Subpart D; or
 - (iii) if the restraint system is recommended for use by an infant with a mass no greater than 10 kg, an unclothed 9-month-old infant ATD that conforms to the requirements of the U.S. *Code of Federal Regulations* (October 1, 1996), Title 49, Part 572, Subpart J.

3. Dynamic Tests

A first dynamic test is to be conducted in accordance with the procedure set out in subsections 3.4 and 3.5 using a new production restraint system for infants with special needs that is attached to the standard seat assembly as shown in Figure 1(a) by the seat belt assembly and a tether strap, if one is provided with the system.

If the restraint system is equipped with a lower connector system, a second dynamic test is to be conducted in accordance with the procedure set out in subsections 3.6 and 3.7 using a new production restraint system for infants with special needs that is attached to the standard seat assembly as shown in Figure 1(b) by the lower universal anchorage system and a tether strap, if one is provided with the system.

3.1 Test Acceleration

The dynamic tests simulate a frontal impact at 48 km/hr. At all points in time until 48 milliseconds after the start of the pulse, the acceleration of the test platform must be above that indicated by the line shown in Figure 2 and such that the total change of velocity is at least 48 km/h.

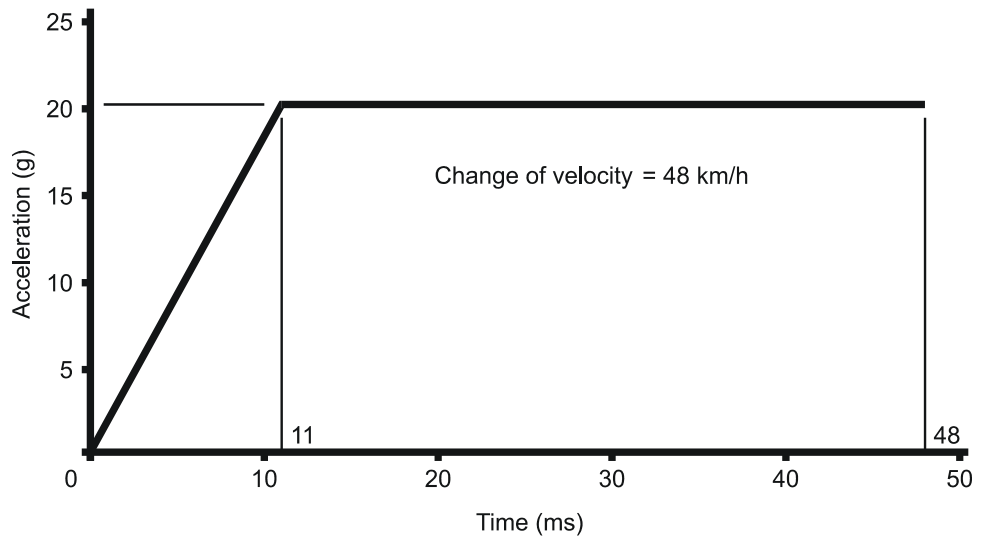

Figure 2 — Test Platform Acceleration Graph

3.2 Test Conditions

For the dynamic tests, the ambient temperature must be from 19°C to 26°C and the relative humidity from 10% to 70%.

3.3 Pre-Test Buckle Release Force Measurement

If the belts of the restraint system are equipped with buckles, the release force of each buckle is to be measured in the following manner before commencing the dynamic tests.

- 3.3.1 Place the buckle assembly on a hard, level surface.
- 3.3.2 Apply a pullout force of 9 N to the buckle assembly in a direction that will produce maximum releasing effect, in the case of
 - (a) A push-button-actuated buckle, at least 3.2 mm from the edge of the push-button access opening of the buckle, or
 - (b) A lever-actuated buckle, on the centreline of the buckle lever or finger tab.
- 3.3.3 Measure the force required to release the buckle and determine its conformance to the requirements of Schedule 7 to the RSSRs.

3.4 *Positioning of the ATD and Installation of the Restraint System for the Dynamic Test Using the Seat Belt Assembly*

- 3.4.1 In accordance with the manufacturer's instructions, place a new restraint system for infants with special needs at the centre seating position of the standard seat assembly. If the restraint system is installed by passing the motor vehicle seat belt over the system and under the ATD, attach the seat belt to the restraint system, but do not tighten it.
- 3.4.2 For the first test, position the Premie ATD specified in paragraph 2.4(a) according to the manufacturer's instructions and as follows:
- (a) With the ATD supine on a horizontal surface, and with a hand placed on its torso to prevent it from moving, lift the feet of the ATD until the legs touch the upper torso and the feet touch the head or as far as they will go. Slowly release the legs, allowing them to come to rest of their own accord. Do not return them to the flat surface.
 - (b) Place the ATD in the restraint system so that its back is in contact with the back support of the system. Attach the belts and the upper and lower torso restraints of the system.
 - (c) Tighten the belts and upper and lower torso restraints until a 9-N force applied using a webbing tension pull device (as illustrated in Figure 3) to the webbing at the top of each shoulder and, if applicable, to the pelvic webbing 50 mm on either side of the mid-sagittal plane of the torso pulls the webbing a distance of 7 mm away from the ATD.
 - (d) Rotate each limb of the ATD downward in a plane parallel to its mid-sagittal plane until the limb is in contact with a surface of the restraint system or the standard seat assembly. The movement of the arms must not be restricted in any but the downward direction.
- 3.4.3 In accordance with the manufacturer's instructions, attach the restraint system, if it is not already installed, to the standard seat assembly using the motor vehicle seat belt; attach the tether strap, if one has been provided; and tighten the seat belt and tether strap to a tension, as measured by a force gauge used on the webbing, of
- (a) until August 31, 2002, not less than 31 N and not more than 49 N or, at the option of the manufacturer, not less than 53.5 N and not more than 67 N; and

- (b) on or after September 1, 2002, not less than 53.5 N and not more than 67 N.

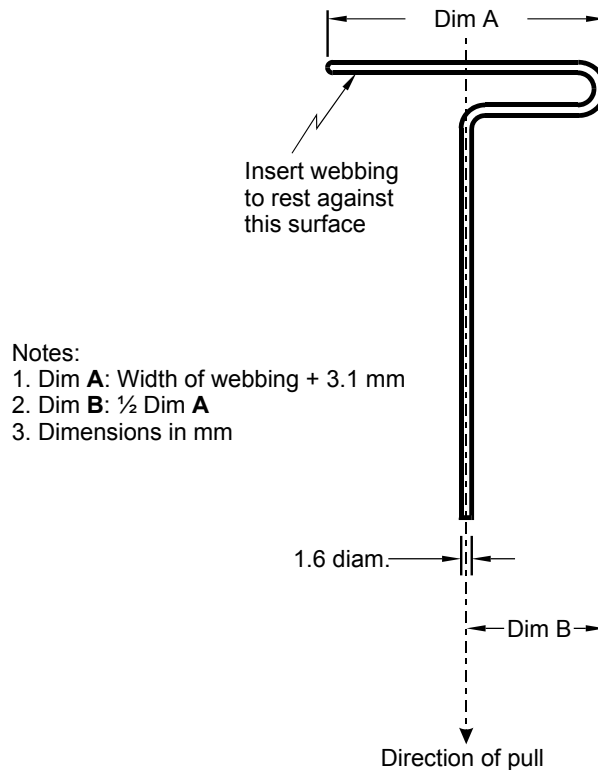

Figure 3 — Webbing Tension Pull Device

3.5 Test Procedure

- 3.5.1 Accelerate the test platform in accordance with the requirements of subsection 3.1.
- 3.5.2 For restraint systems that are not car beds, measure the angle of the seat back and, for both types of systems, determine the conformance of the restraint system to the requirements of section 9 of Schedule 7 to the RSSRs.
- 3.5.3 Depending on the mass range for which the restraint system is designed, the dynamic test procedure must be repeated with a new restraint system and in accordance with the requirements of section 3 using a newborn infant, a 6-month-old infant, or a 9-month-old infant ATD, as specified in paragraph 2.4(b).

3.6 Positioning of the ATD and Installation of the Restraint System for the Dynamic Test Using the Lower Universal Anchorage System

- 3.6.1 Place a new restraint system for infants with special needs at the centre seating position of the standard seat assembly in accordance with the manufacturer's instructions.
- 3.6.2 For the first test, position the Premie ATD specified in paragraph 2.4(a) according to the manufacturer's instructions and as follows:
- (a) With the ATD supine on a horizontal surface, and with a hand placed on its torso to prevent it from moving, lift the feet of the ATD until the legs touch the upper torso and the feet touch the head or as far as they will go. Slowly release the legs, allowing them to come to rest of their own accord. Do not return them to the flat surface.
 - (b) Place the ATD in the restraint system so that its back is in contact with the back support of the system. Attach the belts and the upper and lower torso restraints of the system.
 - (c) Tighten the belts and upper and lower torso restraints until a 9-N force applied using a webbing tension pull device (as illustrated in Figure 4) to the webbing at the top of each shoulder and, if applicable, to the pelvic webbing 50 mm on either side of the mid-sagittal plane of the torso pulls the webbing a distance of 7 mm away from the ATD.
 - (d) Rotate each limb of the ATD downward in a plane parallel to its mid-sagittal plane until the limb is in contact with a surface of the restraint system or the standard seat assembly. The movement of the arms must not be restricted in any but the downward direction.
- 3.6.3 Attach the lower connectors of the restraint system to the lower universal anchorage system and the tether strap, if one has been provided, to the standard seat assembly in the following manner:
- (a) Adjust rigid lower connectors in accordance with the manufacturer's instructions;
 - (b) If a tether strap has been provided, tighten it to a tension of not less than 53.5 N and not more than 67 N, as measured by a force gauge used on the webbing.

3.7 Test Procedure

- 3.7.1 Accelerate the test platform in accordance with the requirements of subsection 3.1.
- 3.7.2 For restraint systems that are not car beds, measure the angle of the seat back and, for both types of systems, determine the conformance of the restraint system to the requirements of section 9 of Schedule 7 to the RSSRs.
- 3.7.3 Depending on the mass range for which the restraint system is designed, the dynamic test procedure must be repeated with a new restraint system and in accordance with the requirements of section 3 using a newborn infant, a 6-month-old infant, or a 9-month-old infant ATD, as specified in paragraph 2.4(b).

3.8 Infant Restraint Systems with a Separate Base

In the case of a system that has a separate, removable base, the seating component of which may be used without the base,

- (a) Where lower connectors are supplied on the base only, the tests described in subsections 3.4 and 3.5 are to be conducted for the seating component and the tests described in subsections 3.4 to 3.7 are to be conducted for the base;
- (b) Where lower connectors are supplied on both the base and the seating component, the tests described in subsections 3.4 to 3.7 are to be conducted for both the base and the seating component.

4. Buckle Release Test Procedure

- 4.1 The release force of each buckle is to be tested with the ATD retained in the restraint system and the system installed in a forward-facing direction. Depending on the mass range for which the restraint system is designed, a newborn infant, a 6-month-old infant, or a 9-month-old infant ATD, as specified in paragraph 2.4(b), must be positioned in the system in accordance with the manufacturer's instructions and the requirements of subsection 3.4.2.
- 4.2 The buckle release force is to be tested as follows:
 - (a) For systems that are not car beds, tie a self-adjusting sling to the wrists and ankles of the ATD, as illustrated in Figure 4.

For car beds, use the self-adjusting sling illustrated in Figure 5.

- (b) While applying a pullout force of 9 N to the buckle assembly in a direction that will produce maximum releasing effect, pull the sling horizontally and parallel to the SORL of the standard seat assembly with a force of 90 N if the system is not a car bed. For car beds, pull the sling vertically with a force of 90 N.

Note: If the restraint system is equipped with a T-shield, a force equivalent to its mass must be added to the pullout force. Any shield, if present, may be adjusted to facilitate application of the pullout force, provided that the harness tension is not significantly affected.

- (c) In order to determine the buckle's conformance to the requirements of section 7 of Schedule 7 to the RSSRs, apply the specified force in a direction that will produce maximum releasing effect, in the case of
- (i) A push-button-actuated buckle, at least 3.2 mm from the edge of the push-button access opening, or
 - (ii) A lever-actuated buckle, on the centreline of the buckle lever or finger tab.
- (d) If the force required to release the buckle exceeds the requirements of Schedule 7 to the RSSRs, release the harness tension and apply a force of 22 to 44 N to the lowest accessible part of the tongue 2 to 4 times in each of four directions at 90-degree angles to each other.
- (e) Repeat paragraphs (b) and (c) above while applying a pullout force on the buckle assembly of 22 N, re-orienting the direction of the sling pull force if necessary so that the arms of the ATD do not load the shield.
- (f) If the buckle does not release at the force specified in Schedule 7 to the RSSRs, repeat paragraphs (b) and (c) once again using a pullout force of 44 N.

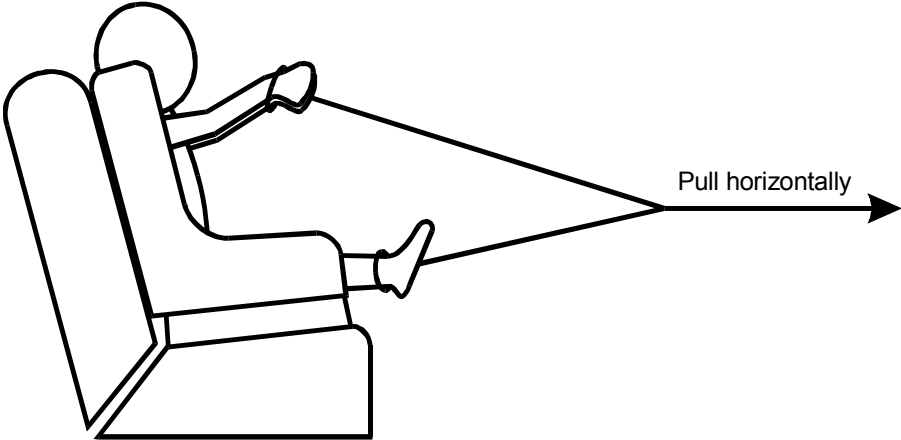

Figure 4 — Self-Adjusting Sling for the Buckle Release Test for Restraint Systems that Are Not Car Beds

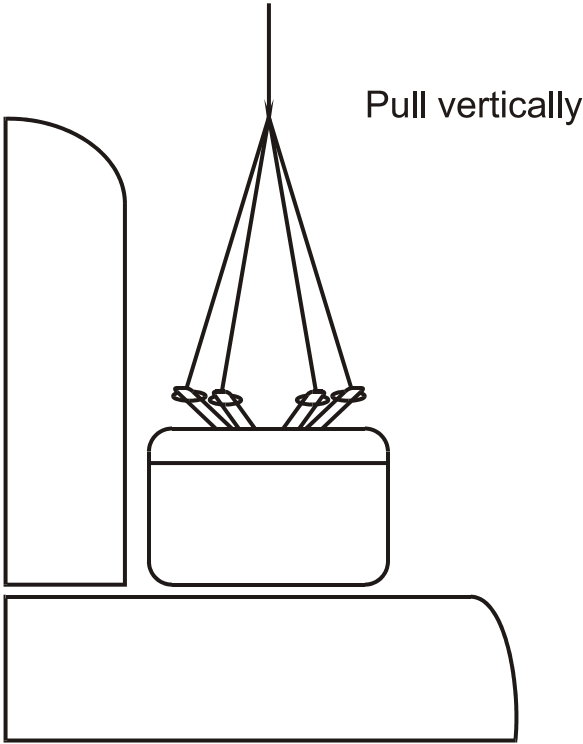

Figure 5 — Self-Adjusting Sling for the Buckle Release Test for Car Beds

5. Energy Absorbing Material Test Procedure

5.1 Prepare and test specimens of energy absorbing material in accordance with the applicable 25% compression-deflection test described in one of the following American Society for Testing and Materials (ASTM) Standards:

- *Standard Specification for Flexible Cellular Materials—Sponge or Expanded Rubber*, Designation No. D 1056-91;
- *Standard Specification for Flexible Cellular Materials—Vinyl Chloride Polymers and Copolymers (Open-Cell Foam)*, Designation No. D 1565-81 (Reapproved 1990); or
- *Standard Test Methods for Flexible Cellular Materials—Slab, Bonded, and Molded Urethane Foams*, Designation No. D 3574-95.

5.2 Determine the conformance of the test specimens to the requirements of section 5 of Schedule 7 to the RSSRs.