

MOTOR VEHICLE SAFETY TEST METHODS

Section: 222

SCHOOL BUS PASSENGER SEATING AND CRASH PROTECTION

1. Subsections 2 to 5 and Figure 1 of this section make up test methods referred to in section 222 of Schedule D to the Motor Vehicle Safety Regulations, to demonstrate compliance with the requirements of section 222 of Schedule D.



Gordon D. Campbell
for Minister of Transport,
Ottawa

222-1

Approved 19 December 1983

MOTOR VEHICLE SAFETY TEST METHODS

2. Symbols

"W" stands for the number of seating positions in a bench seat and shall be calculated as the bench width in millimetres (inches) divided by 381 mm (15 inches) and rounding the quotient to the nearest whole number or, if the quotient is equidistant from two whole numbers, to the higher thereof.

3. Special Test Equipment

3.1 The loading bar, used in 5.1 and 5.2, shall be a rigid cylinder with an outside diameter of 152 mm (6 inches) that has hemispherical ends with radii of 76 mm (3 inches) and with a surface roughness that does not exceed 1.6 μm (63 micro-inches) root mean square.

3.1.1 The length of the loading bar shall be 100 mm (4 inches) less than the width of the seat back in each test.

3.1.2 The stroking mechanism applies force through a pivot attachment at the centre point of the loading bar which allows the loading bar to rotate in a horizontal plane 30 degrees in either direction from the transverse position.

3.1.3 A vertical or lateral force of 17 793 N (4,000 pounds) applied externally through the pivot attachment point of the loading bar at any position reached during a test specified herein, shall not deflect that point more than 25.4 mm (1 inch).

3.2 The head form used for the measurement of acceleration shall be a rigid surface comprised of two hemispherical shapes, with total equivalent weight of 51 N (11.5 pounds). The first of the two hemispherical shapes shall have a diameter of 165 mm (6.5 inches). The second of the two hemispherical shapes shall have a diameter of 50.8 mm (2 inches) and shall be centred as shown in Figure 1 to protrude from the outer surface of the first hemispherical shape. The surface roughness of the hemispherical shapes shall not exceed 1.6 μm (63 micro-inches) root mean square.

3.2.1 The direction of travel of the head form shall be coincidental with the straight line connecting the centre points of the two spherical outer surfaces which constitute the head form shape.

MOTOR VEHICLE SAFETY TEST METHODS

- 3.2.2 The head form shall be instrumented with an acceleration sensing device whose output is recorded in a data channel that conforms to the requirements for a 1000 Hz channel class as specified in SAE Recommended Practice J211a (December 1971). The head form shall not exhibit resonant frequency below three times the frequency of the channel class. The axis of the acceleration sensing device coincides with the straight line connecting the centre points of the two hemispherical outer surfaces which constitute the head form shape.
- 3.2.3 The head form shall be guided by a stroking device so that the direction of travel of the head form is not affected by impact with the surface being tested at the levels called for in the standard.
- 3.3 The knee form for measurement of force shall be a rigid 76 mm (3 inch) diameter cylinder with an equivalent weight of 44.5 N (10 pounds) that has one rigid hemispherical end with a 38 mm (1.5 inch) radius forming the contact surface of the knee form. The hemispherical surface roughness shall not exceed 1.6 μm (63 micro-inches) root mean square.
- 3.3.1 The direction of travel of the knee form shall be coincidental with the centreline of the rigid cylinder.
- 3.3.2 The knee form shall be instrumented with an acceleration sensing device whose output is recorded in a data channel that conforms to the requirements of a 600 Hz channel class as specified in the SAE Recommended Practice J211a (December 1971). The knee form shall not exhibit resonant frequency below three times the frequency of the channel class. The axis of the acceleration sensing device shall be aligned to measure acceleration along the centreline of the cylindrical knee form.
- 3.3.3 The knee form shall be guided by a stroking device so that the direction of travel of the knee form is not affected by impact with the surface being tested at the levels called for herein.

MOTOR VEHICLE SAFETY TEST METHODS

4. Conditions

- 4.1 The following conditions apply to the procedures detailed in section 222, of Schedule D to the Motor Vehicle Safety Regulations, in determining compliance with that section.
- 4.2 The bus shall be at rest on a level surface.
- 4.3 The tires shall be inflated to the pressure specified by the manufacturer for the gross vehicle weight rating.
- 4.4 The ambient temperature shall be any level between 0°C (32°F) and 32°C (90°F).
- 4.5 The Seat back position, if adjustable, shall be adjusted to its most upright position.
- 4.6 The head form, knee form and contactable surfaces shall be clean and dry during impact testing.
- 4.7 The restraining barrier shall meet the barrier performance tests with the drivers' seat located in any of the positions to which it can be adjusted.

5. Test Procedures

5.1 Seat/Restraining Barrier Performance Forward

- 5.1.1 Position the loading bar specified in 3.1 so that it is laterally centred behind the seat back with the bar's longitudinal axis in a transverse plane of the vehicle and in any horizontal plane between 100 mm (4 inches) above, and 100 mm (4 inches) below the seating reference point of the school bus passenger seat behind the test specimen.
- 5.1.2 Apply a force of 3 114W N (700W pounds) horizontally in the forward direction through the loading bar at the pivot attachment point. The specified load shall be reached in not less than 5 nor more than 30 seconds.
- 5.1.3 No sooner than 1.0 second after attaining the required force, reduce that force to 1 557W N (350W pounds) and, while maintaining the pivot point position of the first loading bar at the position where

MOTOR VEHICLE SAFETY TEST METHODS

the 1 557W N (350W pounds) is attained, position a second loading bar described in 3.1 so that it is laterally centered behind the seat back with the bar's longitudinal axis in a transverse plane of the vehicle and in the horizontal plane 406 mm (16 inches) above the seating reference point on the school bus passenger seat behind the test specimen, and move the bar forward against the seat back until a force of 44.5 N (10 pounds) has been applied.

- 5.1.4 Apply additional force horizontally in the forward direction through the upper bar until 452W Nm (4,000W inch-pounds) of energy has been absorbed in deflecting the seat back (or restraining barrier) or until the seat back (or restraining barrier) has been deflected a maximum of 356 mm (14 inches). The additional load shall be applied in not less than 5 seconds nor more than 30 seconds. Maintain the pivot attachment point in the maximum forward travel position for not less than 5 seconds nor more than 10 seconds and release the load in not less than 5 seconds nor more than 30 seconds.

5.2 Seat Performance Test Rearward

- 5.2.1 Position the loading bar described in 3.1 so that it is laterally centered forward of the seat back with the bar's longitudinal axis in a transverse plane of the vehicle and in the horizontal plane 343 mm (13.5 inches) above the seating reference point of the test specimen, and move the loading bar rearward against the seat back until a force of 222.4 N (50 pounds) has been applied.
- 5.2.2 Apply additional force horizontally rearward through the loading bar until 316.4W Nm (2,800W inch-pounds) of energy has been absorbed in deflecting the seat back or until the seat back has been deflected a maximum of 250 mm (10 inches). The additional load shall be applied in not less than 5 seconds nor more than 30 seconds. Maintain the pivot attachment point in the maximum rearward travel position for not less than 5 seconds nor more than 10 seconds and release the load in not less than 5 seconds nor more than 30 seconds.

BISPHERICAL HEADFORM RADII

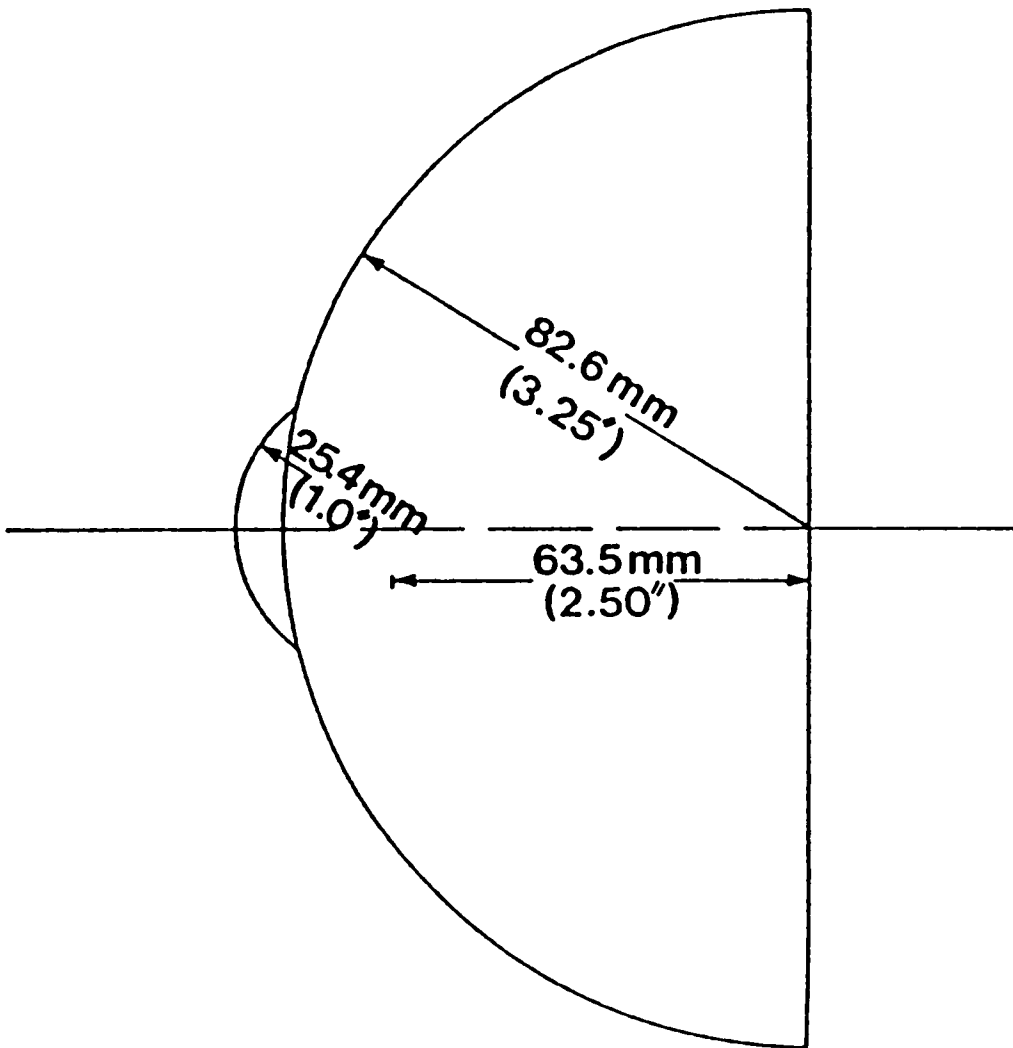

Figure 1