



Transport Canada
Safety and Security

Transports Canada
Sécurité et sûreté

Road Safety

Sécurité routière

Standards and Regulations Division

TECHNICAL STANDARDS DOCUMENT

No. 118, Revision 0

Power-Operated Window, Partition, and Roof Panel Systems

The text of this document is based on Federal Motor Vehicle Safety Standard No. 118, *Power-Operated Window, Partition, and Roof Panel Systems*, as published in the U.S. *Code of Federal Regulations*, Title 49, Part 571, revised as of October 1, 2006.

Effective Date: August 22, 2007
Mandatory Compliance Date: February 22, 2008

Standards Research and Development Branch
Road Safety and Motor Vehicle Regulation Directorate
TRANSPORT CANADA
Ottawa, Ontario
K1A 0N5

**Technical Standards Document
Number 118, Revision 0**

**Power-Operated Window, Partition, and
Roof Panel Systems**

(Ce document est aussi disponible en français.)

Introduction

As defined by section 12 of the *Motor Vehicle Safety Act*, a Technical Standards Document (TSD) is a document that reproduces an enactment of a foreign government (e.g. a Federal Motor Vehicle Safety Standard issued by the U.S. National Highway Traffic Safety Administration). According to the Act, the *Motor Vehicle Safety Regulations* may alter or override some provisions contained in a TSD or specify additional requirements; consequently, it is advisable to read a TSD in conjunction with the Act and its counterpart Regulation. As a guide, where the corresponding Regulation contains additional requirements, footnotes indicate the amending subsection number.

TSDs are revised from time to time in order to incorporate amendments made to the reference document, at which time a Notice of Revision is published in the *Canada Gazette*, Part I. All TSDs are assigned a revision number, with “Revision 0” designating the original version.

Identification of Changes

In order to facilitate the incorporation of a TSD, certain non-technical changes may be made to the foreign enactment. These may include the deletion of words, phrases, figures, or sections that do not apply under the Act or Regulations, the conversion of imperial to metric units, the deletion of superseded dates, and minor changes of an editorial nature. Additions are underlined, and provisions that do not apply are ~~stroked through~~. Where an entire section has been deleted, it is replaced by: “[CONTENT DELETED]”. Changes are also made where there is a reporting requirement or reference in the foreign enactment that does not apply in Canada. For example, the name and address of the U.S. Department of Transportation are replaced by those of the Department of Transport.

Effective Date and Mandatory Compliance Date

Compliance with the requirements of a TSD that is being introduced for the first time is not mandatory until six months after publication in the *Canada Gazette*, Part II, of the Regulations that incorporate the TSD. In the case of a revision, compliance becomes mandatory six months after publication of the Notice of revision in the *Canada Gazette*, Part I, as long as the requirements of the previous version continue to be met. Voluntary compliance is permitted as of the Effective Date of the TSD.

Official Version of Technical Standards Documents

Technical Standards Documents may be consulted electronically in both HTML and Portable Document Format (PDF) on the Department of Transport's Web site at www.tc.gc.ca/RoadSafety/mvstm_tsd/index_e.htm. The PDF version is a replica of the TSD as published by the Department and is to be used for the purposes of legal interpretation and application. The HTML version is provided for information purposes only.

(Original signed by)

Director, Standards Research and Development
for the Minister of Transport, Infrastructure
and Communities
Ottawa, Ontario

TABLE OF CONTENTS

Technical Standards Document Number 118, Revision 0

POWER-OPERATED WINDOW, PARTITION, AND ROOF PANEL SYSTEMS

<i>Introduction</i>	<i>i</i>
<i>S1. Purpose and Scope</i>	<i>1</i>
<i>S2. Application</i>	<i>1</i>
<i>S3. Definitions</i>	<i>1</i>
<i>S4. Operating Requirements</i>	<i>1</i>
<i>S5. Automatic Reversal Systems</i>	<i>2</i>
<i>S6. Actuation Devices</i>	<i>3</i>
<i>S7. Test Procedures</i>	<i>3</i>
S7.1 Test Procedure for Testing Power-Operated Window, Partition, or Roof Panel Systems Designed to Detect Obstructions by Physical Contact or by Light Beam Interruption	3
S7.2 Test Procedure for Testing Power-Operated Window, Partition, or Roof Panel Systems Designed to Detect the Proximity of Obstructions using Infrared Reflectance	4
<i>S8. Test Rods</i>	<i>4</i>
S8.1 Rods for Testing Systems Designed to Detect Obstructions by Physical Contact	4
S8.2 Rods for Testing Systems Designed to Detect Obstructions by Light Beam Interruption	4
S8.3 Rods for Testing Systems Designed to Detect the Proximity of Obstructions using Infrared Reflection	4
<i>S9. Procedure for Measuring the Infrared Reflectance of Test Rod Surface Material</i>	<i>5</i>

TABLE OF FIGURES

Figure 1 — Typical Cylindrical Test Rods Protruding through Sunroof and Window Daylight Openings	6
Figure 2 — Reflectance Test Apparatus	7
Figure 3 — Cylindrical Rod for Testing Non-Contact Infrared Reflection Systems	8

**Technical Standards Document
Number 118, Revision 0**

**POWER-OPERATED WINDOW, PARTITION, AND
ROOF PANEL SYSTEMS**

The text of this document is based on Federal Motor Vehicle Safety Standard No. 118, *Power-Operated Window, Partition, and Roof Panel Systems*, as published in the U.S. *Code of Federal Regulations*, Title 49, Part 571, revised as of October 1, 2006.

S1. Purpose and Scope

This Technical Standards Document (TSD) standard specifies requirements for power-operated window, partition, and roof panel systems to minimize the likelihood of death or injury from their accidental operation.

S2. Application

[CONTENT DELETED] For applicability, see Schedule III and subsections 118(1) and (2) of Schedule IV to the *Motor Vehicle Safety Regulations*.

S3. Definitions

Infrared reflectance means the ratio of the intensity of infrared light reflected and scattered by a flat sample of the test rod material to the intensity of infrared light reflected and scattered by a mirror that reflects 99.99 percent of the infrared radiation incident on its surface, as measured by the apparatus shown in Figure 2. (*Réfectance infrarouge*)

¹ ~~**Power-operated roof panel systems** mean moveable panels in the vehicle roof which close by vehicle-supplied power either by a sliding or hinged motion, and do not include convertible top systems.~~ (*Système de toit ouvrant à commande électrique*)

S4. Operating Requirements

Except as provided in S5, power-operated window, partition, or roof panel systems may be closed only in the following circumstances:

- (a) When the key that controls activation of the vehicle's engine is in the "on", "start", or "accessory" position;
- (b) By muscular force unassisted by vehicle supplied power;
- (c) Upon continuous activation by a locking system on the exterior of the vehicle;

¹ Please see subsection 2(1) of the *Motor Vehicle Safety Regulations* (MVSR) for the applicable definition.

- (d) Upon continuous activation of a remote actuation device, provided that the remote actuation device shall be incapable of closing the power window, partition, or roof panel from a distance of more than 6 meters from the vehicle;
- (e) During the interval between the time the locking device which controls the activation of the vehicle's engine is turned off and the opening of either of a two-door vehicle's doors or, in the case of a vehicle with more than two doors, the opening of either of its front doors;
- (f) If the window, partition, or roof panel is in a static position before starting to close and in that position creates an opening so small that a 4-mm diameter semi-rigid cylindrical rod cannot be placed through the opening at any location around its edge in the manner described in S5(b); or
- (g) Upon continuous activation of a remote actuation device, provided that the remote actuation device shall be incapable of closing the power window, partition, or roof panel if the device and the vehicle are separated by an opaque surface and provided that the remote actuation device shall be incapable of closing the power window, partition, or roof panel from a distance of more than 11 meters from the vehicle.

S5. Automatic Reversal Systems

A power-operated window, partition, or roof panel system that is capable of closing or of being closed under any circumstances other than those specified in S4 shall meet the requirements of S5.1, S5.2, and, if applicable, S5.3.

S5.1 While closing, the power-operated window, partition, or roof panel shall stop and reverse direction either before contacting a test rod with the properties described in S8.2 or S8.3, or before exerting a squeezing force of 100 newtons (N) or more on a semi-rigid cylindrical test rod with the properties described in S8.1, when such test rod is placed through the window, partition, or roof panel opening at any location in the manner described in the applicable test under S7.

S5.2 Upon reversal, the power-operated window, partition, or roof panel system must open to one of the following positions, at the manufacturer's option:

- (a) A position that is at least as open as the position at the time closing was initiated;
- (b) A position that is not less than 125 millimeters (mm) more open than the position at the time the window, partition, or roof panel reversed direction; or
- (c) A position that permits a semi-rigid cylindrical rod that is 200 mm in diameter to be placed through the opening at the same location as the rod described in S7.1 or S7.2(b).

S5.3 If a vehicle uses proximity detection by infrared reflection to stop and reverse a power-operated window, partition, or roof panel, the infrared source shall project infrared light at a wavelength of not less than 850 nm and not more than 1050 nm. The system shall meet the requirements in S5.1 and S5.2 in all ambient light conditions from total darkness to 64,500 lux (6,000 foot candles) incandescent light intensity.

S6. Actuation Devices²

Except as provided in paragraph S6(b), actuation devices in the occupant compartments of vehicles used to close power-operated windows, partitions, and roof panels must meet the following requirements:

- (a) An actuation device must not cause a window, partition, or roof panel to begin to close from any open position when tested as follows:
 - (1) Using a stainless steel sphere having a surface finish between 8 and 4 micro-inches and a radius of $20 \text{ mm} \pm 0.2 \text{ mm}$, place the surface of the sphere against any portion of the actuation device.
 - (2) Apply a force not to exceed 135 N through the geometric center of the sphere. This force may be applied at any angle with respect to the actuation device.
 - (3) For actuation devices that cannot be contacted by the sphere specified in S6(a)(1) prior to the application of force, apply a force up to the level specified in S6(a)(2) at any angle in an attempt to make contact with the actuation device. The sphere is directionally applied in such a manner that, if unimpeded, it would make contact with the actuation device.
- (b) The requirement in S6(a) does not apply to either:
 - (1) actuation devices that are mounted in a vehicle's roof, headliner, or overhead console and that can close power-operated windows, partitions, or roof panels only by continuous rather than momentary switch actuation, or
 - (2) actuation devices for closing power-operated windows, partitions, or roof panels which comply with paragraph S5.
- (c) Any actuation device for closing a power-operated window must operate by pulling away from the surface in the vehicle on which the device is mounted. An actuation device must operate only when pulled vertically up (if horizontally mounted), or out (if vertically mounted), or in a direction perpendicular to the surrounding surface if mounted in a sloped orientation, in order to cause the window to move in the closing direction.

S7. Test Procedures

S7.1 Test Procedure for Testing Power-Operated Window, Partition, or Roof Panel Systems Designed to Detect Obstructions by Physical Contact or by Light Beam Interruption

Place the test rod of the type specified in S8.1 or S8.2, as appropriate, through the window, partition, or roof panel opening from the inside of the vehicle such that the cylindrical surface of the rod contacts any part of the structure with which the window, partition, or roof panel mates. Typical placements of test rods are illustrated in Figure 1. Attempt to close the power window, partition, or roof panel by operating the actuation device provided in the vehicle for that purpose.

² Please see subsection 118(2) of the MVSR for an additional requirement.

S7.2 Test Procedure for Testing Power-Operated Window, Partition, or Roof Panel Systems Designed to Detect the Proximity of Obstructions using Infrared Reflectance

- (a) Place the vehicle under incandescent lighting that projects 64,500 lux (6,000 foot candles) onto the infrared sensor. The light is projected onto the infrared sensor by aiming the optical axis of a light source outside the vehicle as perpendicular as possible to the lens of the infrared sensor. The intensity of light is measured perpendicular to the plane of the lens of the infrared sensor, as close as possible to the center of the lens of the infrared sensor.
- (b) Place a test rod of the type specified in S8.3 in the window, partition, or roof panel opening, with the window, partition, or roof panel in any position. While keeping the rod stationary, attempt to close the window, partition, or roof panel by operating the actuation device provided in the vehicle for that purpose. Remove the test rod. Fully open the window, partition, or roof panel, and then begin to close it. While the window, partition, or roof panel is closing, move a test rod so that it approaches and ultimately extends through (if necessary) the window, partition, or roof panel opening, or its frame, in any orientation from the interior of the vehicle. For power partitions that have occupant compartment space on both sides of the partition, move the test rod into the partition opening from either side of the partition.
- (c) Repeat the steps in S7.2(a) and (b) with other ambient light conditions within the range specified in S5.3.

S8. Test Rods

S8.1 Rods for Testing Systems Designed to Detect Obstructions by Physical Contact

- (a) Each test rod is of cylindrical shape with any diameter in the range from 4 mm to 200 mm and is of sufficient length that it can be hand-held during the test specified in S7 with only the test rod making any contact with any part of the window, partition, or roof panel or mating surfaces of the window, partition, or roof panel.
- (b) Each test rod has a force-deflection ratio of not less than 65 N/mm for rods 25 mm or smaller in diameter, and not less than 20 N/mm for rods larger than 25 mm in diameter.

S8.2 Rods for Testing Systems Designed to Detect Obstructions by Light Beam Interruption

Each test rod has the shape and dimensions specified in S8.1 and is, in addition, opaque to infrared, visible, and ultraviolet light.

S8.3 Rods for Testing Systems Designed to Detect the Proximity of Obstructions using Infrared Reflection

- (a) Each rod is constructed so that its surface has an infrared reflectance of not more than 1.0 percent when measured by the apparatus in Figure 2 in accordance with the procedure in S9.

- (b) Each rod has the shape and dimensions specified in Figure 3.

S9. Procedure for Measuring the Infrared Reflectance of Test Rod Surface Material

- (a) The infrared reflectance of the rod surface material is measured using a flat sample and an infrared light source and sensor operating at a wavelength of 950 ± 100 nm.
- (b) The intensity of incident infrared light is determined using a reference mirror of nominally 100 percent reflectance mounted in place of the sample in the test apparatus in Figure 2.
- (c) Infrared reflectance measurements of each sample of test rod surface material and of the reference mirror are corrected to remove the contribution of infrared light reflected and scattered by the sample holder and other parts of the apparatus before computation of the infrared reflectance ratio.

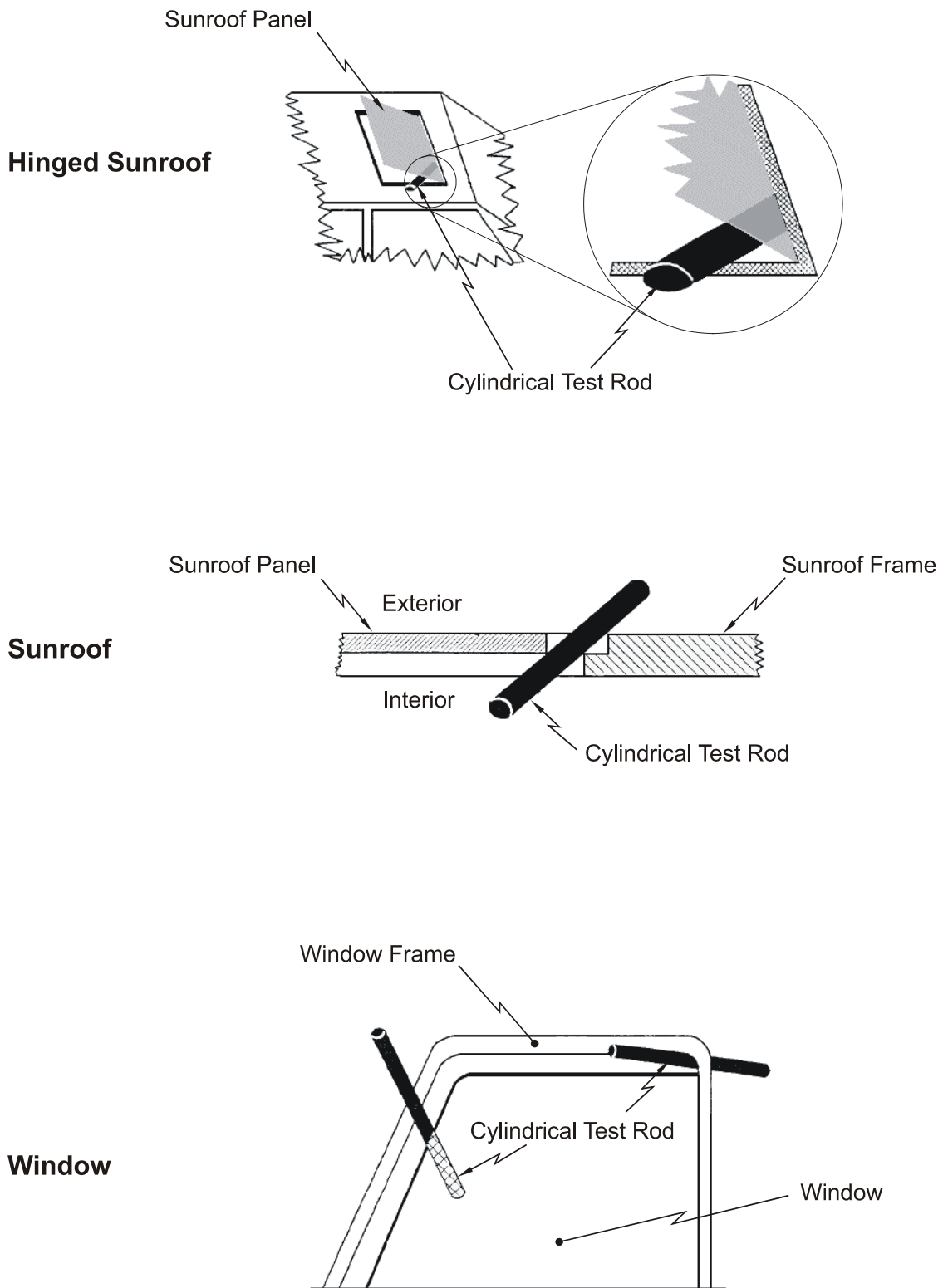
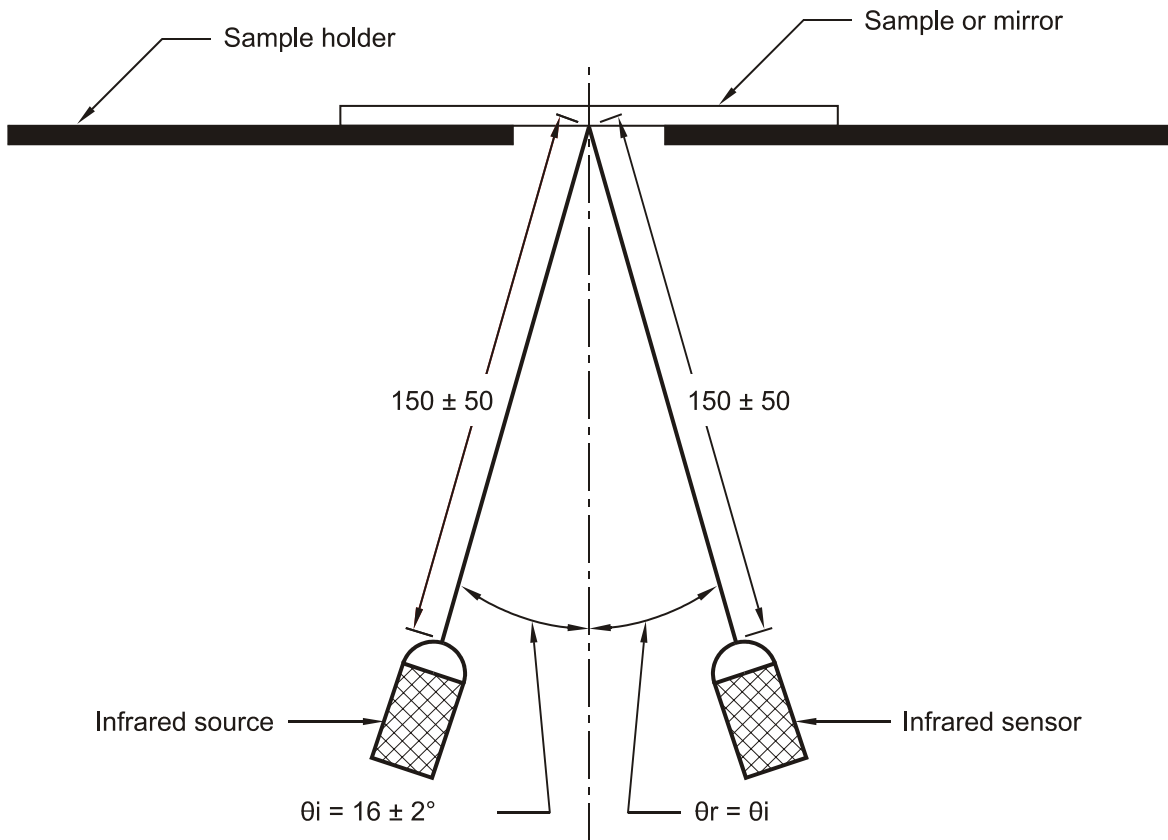
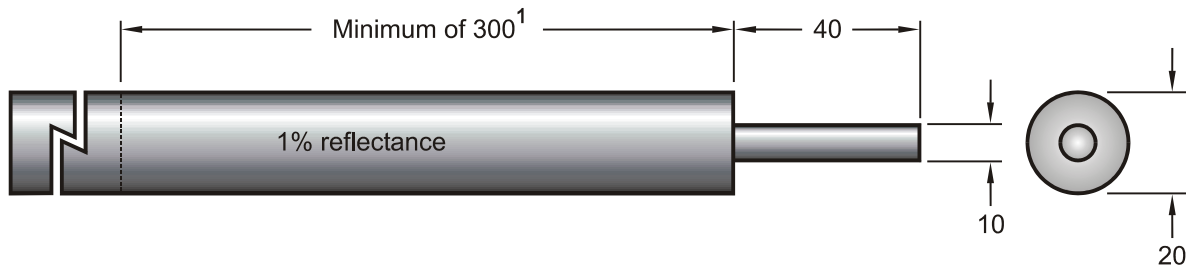

Figure 1 — Typical Cylindrical Test Rods Protruding through Sunroof and Window Daylight Openings



Notes:
 Dimensions in mm
 Not to scale

Figure 2 — Reflectance Test Apparatus



Notes:

¹ Excluding end portion used to hold and position rod during test

Dimensions in mm

Not to scale

Figure 3 — Cylindrical Rod for Testing Non-Contact Infrared Reflection Systems