



Transport Canada  
Safety and Security

Transports Canada  
Sécurité et sûreté

Road Safety

Sécurité routière

**Standards and Regulations Division**

**TECHNICAL STANDARDS DOCUMENT**

**NO. 122, Revision 1**

## **MOTORCYCLE BRAKE SYSTEMS**

The text of this document is based on the U.S. *Code of Federal Regulations, Title 49, Part 571*, Federal Motor Vehicle Safety Standard No. 122, Motorcycle brake systems, revised as of October 1, 1999, and the Final Rule published in the *Federal Register* on August 14, 2001 (Vol. 66, No. 157, p. 42613).

**Effective Date: April 20, 2002**  
**Mandatory Compliance Date: October 20, 2002**

Standards Research and Development Branch  
Road Safety and Motor Vehicle Regulation Directorate  
TRANSPORT CANADA  
Ottawa, Ontario  
K1A 0N5

# Technical Standards Document Number 122, Revision 1

## Motorcycle Brake Systems

(Ce document est aussi disponible en français.)

### Introduction

As defined by section 12 of the *Motor Vehicle Safety Act*, a Technical Standards Document (TSD) is a document that reproduces an enactment of a foreign government (e.g. a Federal Motor Vehicle Safety Standard issued by the U.S. National Highway Traffic Safety Administration). According to the Act, the *Motor Vehicle Safety Regulations* may alter or override some provisions contained in a TSD or specify additional requirements; consequently, it is advisable to read a TSD in conjunction with the Act and its counterpart Regulation. As a guide, where modifications have been made, the corresponding clause number is indicated in the margin of the TSD within parentheses.

TSDs are revised from time to time in order to incorporate amendments made to the reference document, at which time a Notice of Revision is published in the *Canada Gazette* Part I. All TSDs are assigned a revision number, with “Revision 0” designating the original version.

### Identification of Changes

In order to facilitate the incorporation of a TSD, certain non-technical changes may be made to the foreign enactment. These may include the deletion of words, phrases, figures, or sections that do not apply under the Act or Regulations, the conversion of imperial to metric units, the deletion of superseded dates, and minor changes of an editorial nature. Additions are underlined, and provisions that do not apply are ~~stroked through~~. Where an entire section has been deleted, it is replaced by: “[CONTENT DELETED]”. Changes are also made where there is a reporting requirement or reference in the foreign enactment that does not apply in Canada. For example, the name and address of the U.S. Department of Transportation are replaced by those of the Department of Transport.

### Effective Dates

The original version of a TSD comes into effect on the date that the regulation in which it is first incorporated by reference is published in the *Canada Gazette* Part II. Subsequent revisions of a TSD come into effect on the date of publication of the Notice of Revision in the *Canada Gazette* Part I. The Effective Date is that of the publication of the final amendment or the notice of revision in the *Canada Gazette*. Compliance with the requirements of a newly issued TSD is not mandatory until six months following the effective date, during which time it is permissible to continue to comply with the requirements of the previous Regulation or TSD. Manufacturers and importers must comply with the requirements of a newly issued TSD as of the Mandatory Compliance Date.

**Official Version of Technical Standards Documents**

Technical Standards Documents may be consulted electronically in both HTML and Portable Document Format (PDF) on the Department of Transport's Web site at [www.tc.gc.ca/RoadSafety/mvstm\\_tsd/index\\_e.htm](http://www.tc.gc.ca/RoadSafety/mvstm_tsd/index_e.htm). The PDF version is a replica of the TSD as published by the Department and is to be used for the purposes of legal interpretation and application. The HTML version is provided for information purposes only.

(Original signed by)

Director, Standards Research and Development  
for the Minister of Transport,  
Ottawa, Ontario

**TABLE OF CONTENTS****Technical Standards Document  
Number 122, Revision 1****MOTORCYCLE BRAKE SYSTEMS**

<i>Introduction</i>	<i>i</i>
<i>S1. Scope</i>	<i>1</i>
<i>S2. Purpose</i>	<i>1</i>
<i>S3. Application</i>	<i>1</i>
<i>S4. Definitions</i>	<i>1</i>
<i>S5. Requirements</i>	<i>2</i>
<i>S5.1 Required equipment — split service brake system</i>	<i>2</i>
<i>S5.2 Service brake system — first (preburnish) effectiveness</i>	<i>4</i>
<i>S5.3 Service brake system — second effectiveness</i>	<i>4</i>
<i>S5.4 Service brake system — fade and recovery</i>	<i>4</i>
<i>S5.5 Service brake system — final effectiveness</i>	<i>4</i>
<i>S5.6 Parking brake system</i>	<i>5</i>
<i>S5.7 Service brake system-water recovery</i>	<i>5</i>
<i>S5.8 Service brake system design durability</i>	<i>5</i>
<i>S6. Test conditions</i>	<i>5</i>
<i>S6.1 Vehicle <del>mass</del> weight</i>	<i>5</i>
<i>S6.2 Tire inflation pressure</i>	<i>5</i>
<i>S6.3 Transmission</i>	<i>6</i>
<i>S6.4 Engine</i>	<i>6</i>
<i>S6.5 Ambient temperature</i>	<i>6</i>
<i>S6.6 Wind velocity</i>	<i>6</i>
<i>S6.7 Road surface</i>	<i>6</i>
<i>S6.8 Vehicle position</i>	<i>6</i>
<i>S6.9 Thermocouples</i>	<i>6</i>
<i>S6.10 Brake actuation forces</i>	<i>6</i>
<i>S7. Test procedures and sequence</i>	<i>7</i>
<i>S7.1 Braking warming</i>	<i>7</i>

<b>S7.2 Pretest instrumentation check</b>	<b>7</b>
<b>S7.3 Service brake system — first (preburnished) effectiveness test</b>	<b>7</b>
<b>S7.4 Service brake system — burnish procedure</b>	<b>7</b>
<b>S7.5 Service brake system — second effectiveness test</b>	<b>7</b>
<b>S7.6 Service brake system — fade and recovery test</b>	<b>8</b>
<b>S7.7 Service brake system — reburnish</b>	<b>8</b>
<b>S7.8 Service brake system — final effectiveness test</b>	<b>8</b>
<b>S7.9 Parking brake test</b>	<b>9</b>
<b>S7.10 Service brake system-water recovery test</b>	<b>9</b>
<b>S7.11 Final inspection</b>	<b>9</b>

## LIST OF TABLES AND FIGURES

<b>Table I: Stopping Distances for Effectiveness, Fade and Partial System Tests</b>	<b>10</b>
<b>Table II: Brake Test Sequence and Requirements</b>	<b>10</b>
<b>Figure 1: Typical Plug-Type Thermocouple Installations</b>	<b>11</b>
<b>Figure 2: Direction of Force</b>	<b>12</b>

**Technical Standards Document  
Number 122, Revision 1  
MOTORCYCLE BRAKE SYSTEMS**

The text of this document is based on the U.S. *Code of Federal Regulations, Title 49, Part 571*, Federal Motor Vehicle Safety Standard No. 122, Motorcycle brake systems, revised as of October 1, 1999, and the Final Rule published in the *Federal Register* on August 14, 2001 (Vol. 66, No. 157, p. 42613).

**S1. Scope**

This Technical Standards Document (TSD) standard specifies performance requirements for motorcycle brake systems.

**S2. Purpose**

The purpose of this TSD standard is to insure safe motorcycle braking performance under normal and emergency conditions.

(1) **S3. Application**

[CONTENT DELETED] For applicability, see section 122 and Schedule III to the Motor Vehicle Safety Regulations.

**S4. Definitions**

\* **Braking interval** means ~~the distance measured from the start of one brake application to the start of the next brake application.~~ (*intervalle de freinage*)

**Initial brake temperature** means the temperature of the hottest service brake of the vehicle 0.32 km ~~0.2 mile~~ before any brake application. (*température initiale des freins*)

**Skid number** means the frictional resistance of a pavement measured in accordance with American Society for Testing and Materials (ASTM) Method E-274-70 (as revised July, 1974) at 64.4 km/h ~~40 mph~~, omitting water delivery as specified in paragraphs 7.1 and 7.2 of that method. (*coefficient de glissance*)

\* **Stopping distance** means ~~the distance traveled by a vehicle from the start of the brake application to the point where the vehicle stops.~~ (*distance d'arrêt*)

---

\* Please see subsection 2(1) of the Motor Vehicle Safety Regulations for the applicable definition.

\* **Split service brake system** means a brake system consisting of two or more subsystems actuated by a single control designed so that a leakage type failure of a pressure component in a single subsystem (except structural failure of a housing that is common to all subsystems) shall not impair the operation of the other subsystem(s). (*système de frein de service partagé*)

## S5. Requirements

Each motorcycle shall meet the following requirements under the conditions specified in S6, when tested according to the procedures and in the sequence specified in S7. Corresponding test procedures of S7 are indicated in parentheses. If a motorcycle is incapable of attaining a specified speed, its service brakes shall be capable of stopping the vehicle from the multiple of 8.05 km/h ~~5 mph~~ that is 6.44 km/h ~~4 mph~~ to 12.88 km/h ~~8 mph~~ less than the speed attainable in 1.61 km ~~1 mile~~, within stopping distances that do not exceed the stopping distances specified in Table 1.

### S5.1 Required equipment — split service brake system

Each motorcycle shall have either a split service brake system or two independently actuated service brake systems.

**S5.1.1 Mechanical service brake system.** Failure of any component in a mechanical service brake system shall not result in a loss of braking ability in the other service brake system on the vehicle.

**S5.1.2 Hydraulic service brake system.** A leakage failure in a hydraulic service brake system shall not result in a loss of braking ability in the other service brake system on the vehicle. Each motorcycle equipped with a hydraulic brake system shall have the equipment specified in S5.1.2.1 and S5.1.2.2.

**S5.1.2.1 Master cylinder reservoirs.** Each master cylinder shall have a separate reservoir for each brake circuit, with each reservoir filler opening having its own cover, seal, and cover retention device. Each reservoir shall have a minimum capacity equivalent to one and one-half times the total fluid displacement resulting when all the wheel cylinders or caliper pistons serviced by the reservoir move from a new lining, fully retracted position to a fully worn, fully applied position. Where adjustment is a factor, the worst condition of adjustment shall be used for this measurement.

(2)\*\* **S5.1.2.2 Reservoir labeling.** Each motorcycle shall have a brake fluid warning statement that reads as follows, in letters at least 2.38 mm ~~three thirty seconds of an inch~~ high:

Warning: Clean filler cap before removing. Use only \_\_\_\_ fluid from a sealed container.

(Inserting the recommended type of brake fluid as specified in 49 CFR 571.116, e.g.,

---

\*\* The numbers in parentheses in the margin refer to subsections of section 122 of the Regulations that supersede the requirements of the TSD provision.

DOT 3.) The lettering shall be:—

- (a) Permanently affixed, engraved, or embossed;
- (b) Located so as to be visible by direct view, either on or within 101.6 mm ~~4 inches~~ of the brake-fluid reservoir filler plug or cap; and
- (c) Of a color that contrasts with its background, if it is not engraved or embossed.

**S5.1.3 Split service brake system.** In addition to the equipment required by S5.1.2 each motorcycle equipped with a split service brake system shall have a failure indicator lamp as specified in S5.1.3.1.

**S5.1.3.1 Failure indicator lamp**

- (a) One or more electrically operated service brake system failure indicator lamps that is mounted in front of and in clear view of the driver, and that is activated —
  - (1) In the event of pressure failure in any part of the service brake system, other than a structural failure of either a brake master cylinder body in a split integral body type master cylinder system or a service brake system failure indicator body, before or upon application of not more than 89 N ~~20 pounds~~ of pedal force upon the service brake.
  - (2) Without the application of pedal force, when the level of brake fluid in a master cylinder reservoir drops to less than the recommended safe level specified by the manufacturer or to less than one-half the fluid reservoir capacity, whichever is the greater.
- (b) All failure indicator lamps shall be activated when the ignition switch is turned from the “off” to the “on” or to the “start” position.
- (c) Except for the momentary activation required by S5.1.3.1(b), each indicator lamp, once activated, shall remain activated as long as the condition exists, whenever the ignition switch is in the “on” position. An indicator lamp activated when the ignition is turned to the “start” position shall be deactivated upon return of the switch to the “on” position unless a failure exists in the service brake system.
- (3) (d) Each indicator lamp shall have a red lens with the legend “Brake Failure” on or adjacent to it in letters not less than 2.38 mm ~~three thirty-seconds of an inch~~ high that shall be legible to the driver in daylight when lighted.

**S5.1.4 Parking brake.** Each three-wheeled motorcycle shall be equipped with a parking brake of a friction type with a solely mechanical means to retain engagement.

**S5.1.5 Other requirements.** The brake system shall be installed so that the lining thickness of drum brake shoes may be visually inspected, either directly or by use of a mirror without removing the drums, and so that disc brake friction lining thickness may be visually inspected without removing the pads.



**S5.2 Service brake system — first (preburnish) effectiveness**

**S5.2.1 Service brake system.** The service brakes shall be capable of stopping the motorcycle from ~~48.3 km/h 30 mph~~ and ~~96.6 km/h 60 mph~~ within stopping distances which do not exceed the stopping distances specified in Column I of Table I (S7.3.1).

**S5.2.2 Partial service brake system.** Each independently actuated service brake system on each motorcycle shall be capable of stopping the motorcycle from ~~48.3 km/h 30 mph~~ and ~~96.6 km/h 60 mph~~ within stopping distances which do not exceed the stopping distances specified in Column II of Table I (S7.3.2).

**S5.3 Service brake system — second effectiveness**

The service brakes shall be capable of stopping the motorcycle from ~~48.3 km/h 30 mph~~, ~~96.6 km/h 60 mph~~, ~~128.8 km/h 80 mph~~, and the multiple of ~~8.05 km/h 5 mph~~ that is ~~6.44 km/h 4 mph~~ to ~~12.88 km/h 8 mph~~ less than the speed attainable in ~~1.61 km 1 mile~~ if this speed is ~~152.95 km/h 95 mph~~ or greater, within stopping distances that do not exceed the stopping distances specified in Column III of Table I (S7.5).

(5) **S5.4 Service brake system — fade and recovery**

These requirements do not apply to a limited-speed motorcycle ~~motor-driven cycle~~ whose speed attainable in ~~1.61 km 1 mile~~ is ~~48.3 km/h 30 mph~~ or less.

**S5.4.1 Baseline check-minimum and maximum pedal forces.** The pedal and lever forces used in establishing the fade baseline check average shall be within the limits specified in S6.10 (S7.6.1).

**S5.4.2 Fade.** Each motorcycle shall be capable of making 10 fade stops from ~~96.6 km/h 60 mph~~ at not less than ~~4.57 m/s<sup>2</sup> 15 ft/s<sup>2</sup>~~ for each stop (S7.6.2).

**S5.4.3 Fade recovery.** Each motorcycle shall be capable of making five recovery stops with a pedal force that does not exceed 400 N (90 pounds) and a hand lever force that does not exceed 245 N (55 pounds) for any of the first four recovery stops and that, for the fifth recovery stop, is within plus 89 N (20 pounds) and minus 44 N (10 pounds) of the fade test baseline check average force (S7.6.3), but not less than 0 N (0 pounds).

(5) **S5.5 Service brake system — final effectiveness**

These requirements do not apply to a limited-speed motorcycle ~~motor-driven cycle~~ whose speed attainable in ~~1.61 km 1 mile~~ is ~~48.3 km/h 30 mph~~ or less.

**S5.5.1 Service brake system.** The service brakes shall be capable of stopping the motorcycle in a manner that complies with S5.3 (S7.8.1).

**S5.5.2 Hydraulic service brake system-partial failure.** In the event of a pressure component leakage failure, other than a structural failure of either a brake master cylinder body in a split integral body type master cylinder system or a service brake system failure

indicator body, the remaining portion of the service brake system shall continue to operate and shall be capable of stopping the motorcycle from 48.3 km/h ~~30 mph~~ and 96.6 km/h ~~60 mph~~ within stopping distances that do not exceed the stopping distances specified in Column IV of Table I (S7.8.2).

### **S5.6 Parking brake system**

The parking brake system shall be capable of holding the motorcycle stationary (to the limits of traction of the braked wheels), for 5 minutes, in both forward and reverse directions, on a 30 percent grade, with an applied force of not more than 400 N ~~90 pounds~~ for a foot-operated system and 245 N ~~55 pounds~~ for a hand-operated system (S7.9).

### **S5.7 Service brake system-water recovery**

**S5.7.1 Baseline check.** The pedal and lever forces used in establishing the water recovery baseline check average shall be within the limits specified in S6.10 (S7.10.1).

**S5.7.2 Water recovery test.** Each motorcycle shall be capable of making five recovery stops with a pedal force that does not exceed 400 N (90 pounds) and a hand lever force that does not exceed 245 N (55 pounds) for any of the first four recovery stops and that, for the fifth recovery stop, is within plus 89 N (20 pounds) and minus 44 N (10 pounds) of the water recovery baseline check average force (S7.10.2), but not less than 0 N (0 pounds).

### **S5.8 Service brake system design durability**

Each motorcycle shall be capable of completing all braking requirements of S5 without detachment of brake linings from the shoes or pad, detachment or fracture of any brake system components, or leakage of fluid or lubricant at the wheel cylinder, and master cylinder reservoir cover, seal, or retention device (S7.11).

## **S6. Test conditions**

The requirements of S5 shall be met under the following conditions. Where a range of conditions is specified, the motorcycle shall be capable of meeting the requirements at all points within the range.

### **(4) S6.1 Vehicle mass weight**

Motorcycle mass weight is unloaded vehicle mass weight plus 90.72 kg ~~200 pounds~~ (including driver and instrumentation), with the added mass weight distributed in the saddle or carrier if so equipped.

### **S6.2 Tire inflation pressure**

Tire inflation pressure is the pressure recommended by the manufacturer for the vehicle mass weight specified in paragraph S6.1.

### S6.3 Transmission

Unless otherwise specified, all stops are made with the clutch disengaged.

### S6.4 Engine

Engine idle speed and ignition timing settings are according to the manufacturer's recommendations. If the vehicle is equipped with an adjustable engine speed governor, it is adjusted according to the manufacturer's recommendation.

### S6.5 Ambient temperature

The ambient temperature is between 0° C 32° F and 37.8° C 100° F.

(6) **S6.6 Wind velocity**

The wind velocity is zero.

### S6.7 Road surface

Road tests are conducted on level roadway having a skid number of 81. The roadway is 2.44 m 8 feet wide for two-wheeled motorcycles, and overall vehicle width plus 1.52 m 5 feet for three-wheeled motorcycles. The parking brake test surface is clean, dry, smooth portland cement concrete.

### S6.8 Vehicle position

The motorcycle is aligned in the center of the roadway at the start of each brake application. Stops are made without any part of the motorcycle leaving the roadway and without lockup of any wheel.

### S6.9 Thermocouples

The brake temperature is measured by plug-type thermocouples installed in the approximate center of the facing length and width of the most heavily loaded shoe or disc pad, one per brake, as shown in Figure 1.

### S6.10 Brake actuation forces

Except for the requirements of the fifth recovery stop in S5.4.3 and S5.7.2 (S7.6.3 and S7.10.2), the hand lever force is not less than 10 N (2.3 pounds) and not more than 245 N (55 pounds) and the foot pedal force is not less than 25 N (5.6 pounds) and not more than 400 N (90 pounds). The point of initial application of the lever forces is 30 mm 1.2 inches from the end of the brake lever grip. The direction of the force is perpendicular to the handle grip on the plane along which the brake lever rotates, and the point of application of the pedal force is the center of the foot contact pad of the brake pedal. The direction of the force is perpendicular to the foot contact pad on the plane along which the brake pedal rotates, as shown in Figure 2.

## S7. Test procedures and sequence

Each motorcycle shall be capable of meeting all the requirements of this TSD standard when tested according to the procedures and in the sequence set forth below without replacing any brake system part, or making any adjustments to the brake system other than as permitted in S7.4. A motorcycle shall be deemed to comply with S5.2, S5.3 and S5.5 if at least one of the stops specified in S7.3, S7.5 and S7.8 is made within the stopping distances specified in Table I.

### S7.1 Braking warming

If the initial brake temperature for the first stop in a test procedure (other than S7.10) has not been reached, heat the brakes to the initial brake temperature by making up to 10 stops from 48.3 km/h 30 mph at a deceleration of not more than 3.05 m/s<sup>2</sup> 10 ft/s<sup>2</sup>. On independently operated brake systems, the coldest brake shall be within 5.56° C 10° F of the hottest brake.

### S7.2 Pretest instrumentation check

Conduct a general check of test instrumentation by making not more than 10 stops from a speed of not more than 48.3 km/h 30 mph at a deceleration of not more than 3.05 m/s<sup>2</sup> 10 ft/s<sup>2</sup>. If test instrument repair, replacement, or adjustment is necessary, make not more than 10 additional stops after such repair, replacement or adjustment.

### S7.3 Service brake system — first (preburnished) effectiveness test

**S7.3.1 Service brake system.** Make six stops from 48.3 km/h 30 mph and then six stops from 96.6 km/h 60 mph with an initial brake temperature between 54.4° C 130° F and 65.6° C 150° F.

**S7.3.2 Partial service brake system.** For a motorcycle with two independently actuated service brake systems, repeat S7.3.1 using each service brake system individually.

### S7.4 Service brake system — burnish procedure

Burnish the brakes by making 200 stops from 48.3 km/h 30 mph at 3.66 m/s<sup>2</sup> 12 ft/s<sup>2</sup>. The braking interval shall be either the distance necessary to reduce the initial brake temperature to between 54.4° C 130° F and 65.6° C 150° F or 1.61 km 1 mile, whichever occurs first. Accelerate at maximum rate to 48.3 km/h 30 mph immediately after each stop and maintain that speed until making the next stop. After burnishing adjust the brakes in accordance with the manufacturer's recommendation.

### S7.5 Service brake system — second effectiveness test

Repeat S7.3.1. Then, make four stops from 128.8 km/h 80 mph and four stops from the multiple of 8.05 km/h 5 mph that is 6.44 km/h 4 mph to 12.88 km/h 8 mph less than the speed attainable in 1.61 km 1 mile if that speed is 152.95 km/h 95 mph or greater.

(5) **S7.6 Service brake system — fade and recovery test**

These requirements do ~~not~~ apply to a limited-speed motorcycle ~~motor-driven cycle~~ whose speed attainable in 1.61 km ~~1 mile~~ is 48.3 km/h ~~30 mph~~ or less.

**S7.6.1 Baseline check stops.** Make three stops from 48.3 km/h ~~30 mph~~ at 3.05 to 3.35 m/s<sup>2</sup> ~~10 to 11 ft/s<sup>2</sup>~~ for each stop. Compute the average of the maximum brake pedal forces and the maximum brake lever forces required for the three stops.

(7) **S7.6.2 Fade stops.** Make 10 stops from 96.6 km/h ~~60 mph~~ at not less than 4.57 m/s<sup>2</sup> ~~15 ft/s<sup>2</sup>~~ for each stop. The initial brake temperature before the first brake application shall be between 54.4° C ~~130° F~~ and 65.6° C ~~150° F~~. Initial brake temperatures before brake applications for subsequent stops shall be those occurring at the distance intervals. Attain the required deceleration as quickly as possible and maintain at least this rate for not less than three-fourths of the total stopping distance for each stop. The interval between the starts of service brake applications shall be 0.64 km ~~0.4 mile~~. Drive 1.61 km ~~1 mile~~ at 48.3 km/h ~~30 mph~~ after the last fade stop and immediately conduct the recovery test specified in S7.6.3.

**S7.6.3 Recovery test.** Make five stops from 48.3 km/h ~~30 mph~~ at 3.05 to 3.35 m/s<sup>2</sup> ~~10 to 11 ft/s<sup>2</sup>~~ for each stop. The braking interval shall not be more than 1.61 km ~~1 mile~~. Immediately after each stop accelerate at maximum rate to 48.3 km/h ~~30 mph~~ and maintain that speed until making the next stop.

(5) **S7.7 Service brake system — reburnish**

Repeat S7.4 except make 35 burnish stops instead of 200 stops. Brakes may be adjusted after reburnish if no tools are used. These requirements do ~~not~~ apply to a limited-speed motorcycle ~~motor-driven cycle~~ whose speed attainable in 1.61 km ~~1 mile~~ is 48.3 km/h ~~30 mph~~ or less.

(5) **S7.8 Service brake system — final effectiveness test**

These requirements do ~~not~~ apply to a limited-speed motorcycle ~~motor-driven cycle~~ whose speed attainable in 1.61 km ~~1 mile~~ is 48.3 km/h ~~30 mph~~ or less.

**S7.8.1 Service brake system.** Repeat S7.5 including S7.3.1.

**S7.8.2 Partial service brake system test.** Alter the service brake system on three-wheeled motorcycles to induce a complete loss of braking in any one subsystem. Determine the line pressure or pedal force necessary to cause the brake system failure indicator to operate. Make six stops from 48.3 km/h ~~30 mph~~ and then six stops from 96.6 km/h ~~60 mph~~ with an initial brake temperature between 54.4° C ~~130° F~~ and 65.6° C ~~150° F~~. Repeat for each subsystem. Determine that the brake failure indicator is operating when the master cylinder fluid level is less than the level specified in S5.1.3.1(a)(2), and that it complies with S5.1.3.1(c). Check for proper operation with each reservoir in turn at a low level. Restore the service brake system to normal at completion of this test.

### S7.9 Parking brake test

Starting with an initial brake temperature of not more than  $65.6^{\circ}\text{C}$   $150^{\circ}\text{F}$ , drive the motorcycle downhill on the 30 percent grade with the longitudinal axis of the motorcycle in the direction of the grade. Apply the service brakes with a force not exceeding  $400\text{ N}$  ~~90 pounds~~ to stop the motorcycle and place the transmission in neutral. Apply the parking brake by exerting a force not exceeding those specified in S5.6. Release the service brake and allow the motorcycle to remain at rest (to the limit of traction of the braked wheels) for 5 minutes. Repeat the test with the motorcycle parked in the reversed (uphill) position on the grade.

### S7.10 Service brake system-water recovery test

**S7.10.1 Baseline check stops.** Make three stops from  $48.3\text{ km/h}$  ~~30 mph~~ at  $3.05$  to  $3.35\text{ m/s}^2$  ~~10 to 11 ft/s<sup>2</sup>~~ for each stop. Compute the average of the maximum brake pedal forces and of the maximum brake lever forces required for the three stops.

**S7.10.2 Wet brake recovery stops.** Completely immerse the rear brake assembly of the motorcycle in water for 2 minutes with the brake fully released. Next completely immerse the front brake assembly of the motorcycle in water for 2 minutes with the brake fully released. Perform the entire wetting procedure in not more than 7 minutes. Immediately after removal of the front brake from water, accelerate at a maximum rate to  $48.3\text{ km/h}$  ~~30 mph~~ without a brake application. Immediately upon reaching that speed make five stops, each from  $48.3\text{ km/h}$  ~~30 mph~~ at  $3.05$  to  $3.35\text{ m/s}^2$  ~~10 to 11 ft/s<sup>2</sup>~~ for each stop. After each stop (except the last) accelerate the motorcycle immediately at a maximum rate to  $48.3\text{ km/h}$  ~~30 mph~~ and begin the next stop.

### S7.11 Final inspection

Upon completion of all the tests inspect the brake system in an assembled condition, for compliance with the brake lining inspection requirements. Disassemble all brakes and inspect:

- (a) The entire brake system for detachment or fracture of any component.
- (b) Brake linings for detachment from the shoe or pad.
- (c) Wheel cylinder, master cylinder, and axle seals for fluid or lubricant leakage.
- (d) Master cylinder for reservoir capacity and retention device.
- (e) Master cylinder label for compliance with S5.1.2.2.

**Table I: Stopping Distances for Effectiveness, Fade and Partial System Tests**

Vehicle Test Speed		Stopping distance — Effectiveness tests							
		Preburnish effectiveness total system (S5.2.1) — I		Preburnish effectiveness partial mechanical systems (S5.2.2) — II		Effectiveness total system (S5.3) (S7.5)—III		Effectiveness partial hydraulic systems (S5.5.2) — IV	
		km/h	mph	m.	ft.	m.	ft.	m.	ft.
24.15	45	3.96	43	9.15	30	3.35	44	7.62	25
32.20	20	7.32	24	16.46	54	5.79	49	13.41	44
40.25	25	11.28	37	25.61	84	9.15	30	20.73	68
48.3	30	16.46	54	36.89	124	13.11	43	29.57	97
56.35	35	22.56	74	50.30	165	17.68	58	40.23	132
64.40	40	29.27	96	65.85	216	22.87	75	52.73	173
72.45	45	36.88	124	83.23	273	28.96	95	66.45	218
80.50	50	45.73	150	102.74	337	39.02	128	80.47	264
88.55	55	55.18	184	124.09	407	47.26	155	99.36	326
96.60	60	65.85	216	147.56	484	56.40	185	118.26	388
104.65	65					66.16	217	138.68	455
112.70	70					80.49	264	160.63	527
120.75	75					92.38	303	184.71	606
128.80	80					105.18	345	210.01	689
136.85	85					118.60	389	237.13	778
144.90	90					147.56	484	265.79	872
152.95	95					164.63	540	295.96	974
161.00	100					182.32	598	327.96	1076
169.05	105					200.91	659	362.10	1188
177.10	110					220.43	723	396.85	1302
185.15	115					241.16	794	433.73	1423
193.20	120					262.50	864	472.14	1549

**Table II: Brake Test Sequence and Requirements**

Sequence	Test procedure	Requirements
1. Instrumentation check	S7.2	
2. First (Preburnish) effectiveness test		
(a) Service brake system	S7.3.1	S5.2.1
(b) Partial service brake system	S7.3.2	S5.2.2
3. Burnish procedure	S7.4	
4. Second effectiveness test	S7.5	S5.3
5. First fade and recovery test	S7.6	S5.4
6. Reburnish	S7.7	
7. Final effectiveness test		
(a) Service brake system	S7.8.1	S5.5.1
(b) Partial service brake system	S7.8.2	S5.5.2
8. Parking brake test (three-wheeled motorcycles only)	S7.9	S5.6
9. Water recovery test	S7.10	S5.7
10. Design durability	S7.11	S5.8

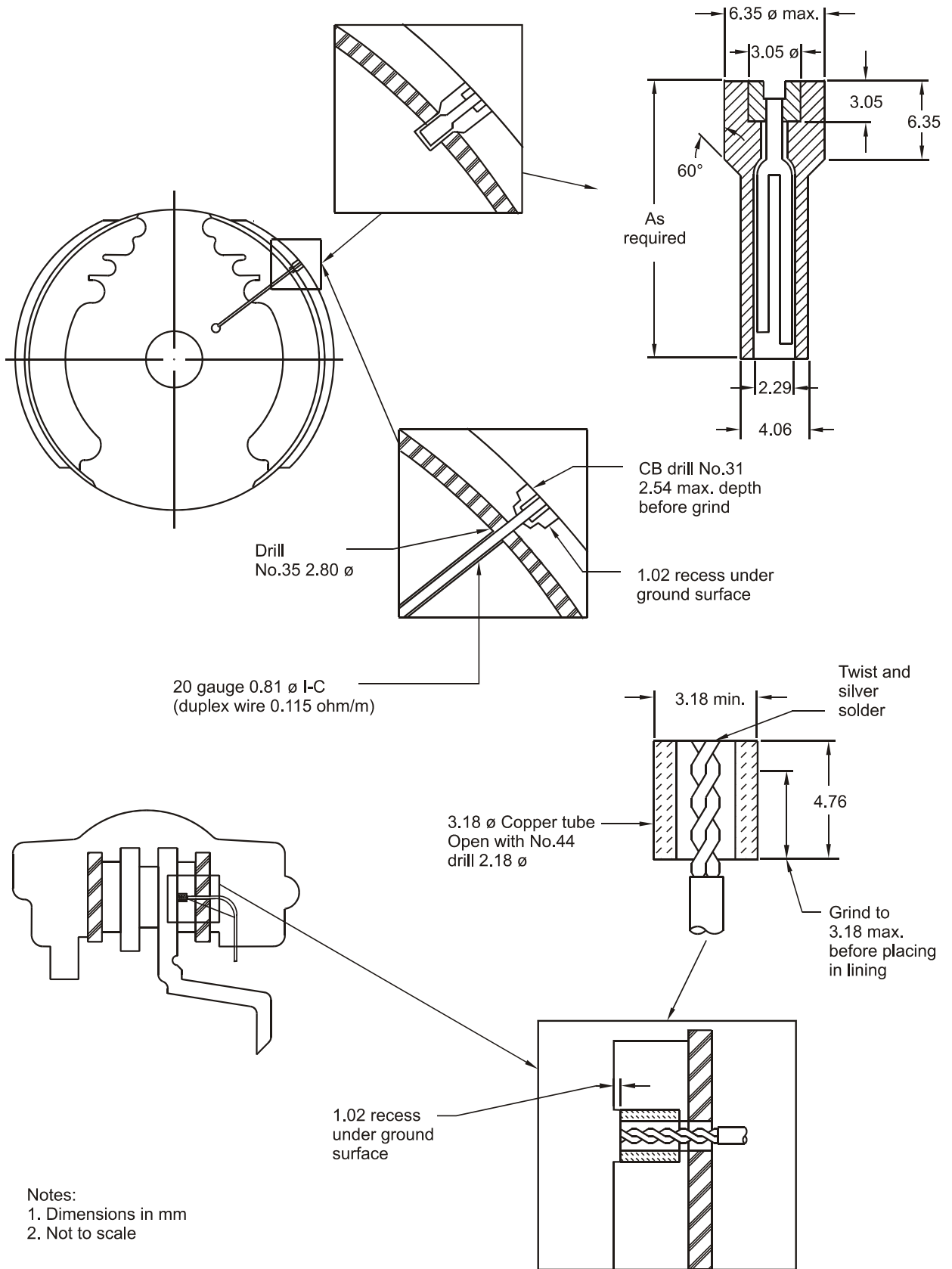
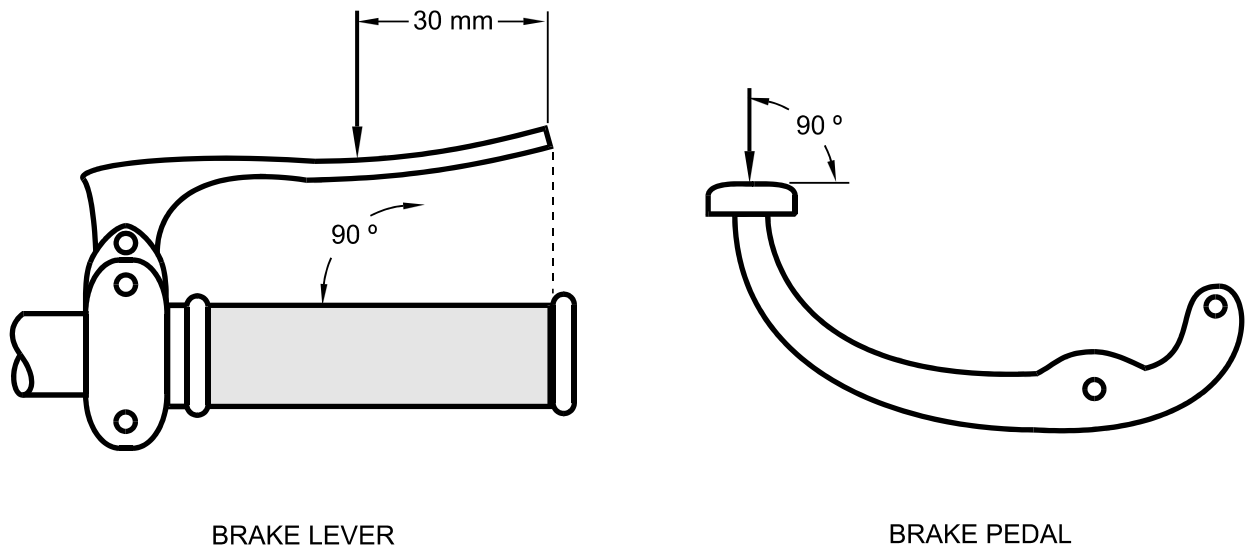

Figure 1: Typical Plug-Type Thermocouple Installations





Note:  
Not to scale

Figure 2: Direction of Force