



Transport Canada
Safety and Security

Transports Canada
Sécurité et sûreté

Road Safety

Sécurité routière

Standards and Regulations Division

TECHNICAL STANDARDS DOCUMENT

NO. 131

SCHOOL BUS PEDESTRIAN SAFETY DEVICES

Issued: July 4, 1995
Revised: June 23, 1999

Motor Vehicle Standards and Research Branch
Road Safety and Motor Vehicle Regulation Directorate
TRANSPORT CANADA
Ottawa, Ontario
K1A 0N5

Technical Standards Document Number 131

SCHOOL BUS PEDESTRIAN SAFETY DEVICES

(Ce document est aussi disponible en français.)

Introduction

This Technical Standards Document reproduces the technical content of Federal Motor Vehicle Safety Standard No. 131, “School Bus Pedestrian Safety Devices”, issued by the National Highway Traffic Safety Administration of the United States Department of Transportation. The general requirements governing Technical Standards Documents (TSD) are set out in section 12 of the *Motor Vehicle Safety Act*, which allows for the use of a TSD to incorporate enactments of a foreign government. Because the requirements of the *Motor Vehicle Safety Regulations* may change the provisions of a TSD, this Document should be read in conjunction with the *Motor Vehicle Safety Act* and section 131 of the Regulations. As a guide, the subsection of the Regulations that alters or limits a TSD provision is indicated in the margin by the number within parentheses. Amendments to this TSD will be issued from time to time to incorporate revisions made to the reference document, and a Notice of Revision announcing an amendment will be published in the *Canada Gazette* Part I. The revised TSD will become effective on the date of publication of the Notice, but it is not enforceable until six months after that date.

Certain non-technical changes have been made to the U.S. standard by the Department of Transport. These include the deletion of words, phrases, and sections that do not apply under the Act or Regulations, the conversion of imperial to metric units, and minor changes of an editorial nature. Additions have been underlined, and provisions that do not apply have been ~~stroked through~~. Where an entire section has been deleted, it has been replaced by: “[CONTENT DELETED]”. Changes have also been made where there is a reference in the U.S. standard that does not apply in Canada.

Official Version of Technical Standards Documents

Technical Standards Documents may be consulted electronically in both HTML and Portable Document Format (PDF) on the Department of Transport’s Web site at www.tc.gc.ca/RoadSafety/mvstm_tsd/index_e.htm. The PDF version is a replica of the TSD as published by the Department and is to be used for the purposes of legal interpretation and application. The HTML version is provided for information purposes only.

(Original signed by)

Director, Motor Vehicle Standards and Research
for the Minister of Transport,
Ottawa

TABLE OF CONTENTS

**Technical Standards Document
Number 131**

SCHOOL BUS PEDESTRIAN SAFETY DEVICES

<i>Introduction</i>	<i>i</i>
<i>S1. Scope</i>	<i>1</i>
<i>S2. Purpose</i>	<i>1</i>
<i>S3. Application</i>	<i>1</i>
<i>S4. Definition</i>	<i>1</i>
<i>S5. Requirements</i>	<i>1</i>
<i>S6. Test Procedures</i>	<i>3</i>
Figure 1: Characteristics of Stop Signal Device	5

**Technical Standards Document
Number 131
SCHOOL BUS PEDESTRIAN SAFETY DEVICES**

The text of this document is based on the U.S. *Code of Federal Regulations, Title 49, part 571*, Federal Motor Vehicle Safety Standard No. 131, SCHOOL BUS PEDESTRIAN SAFETY DEVICES, and subsequent amendments, revised as of October 1, 1992, up to and including the Final Rule, Docket 98-3870, Notice 7, published in the *Federal Register* on May 28, 1998 (Vol. 63, No. 102, p. 29139).

S1. Scope

This Technical Standards Document (TSD) standard establishes requirements for devices that must be installed on school buses to improve the safety of pedestrians in the vicinity of stopped school buses.

S2. Purpose

The purpose of this TSD standard is to reduce deaths and injuries by minimizing the likelihood of vehicles passing a stopped school bus and striking pedestrians in the vicinity of the bus.

(1) **S3. Application**

[CONTENT DELETED] For applicability, see Schedule III of the *Motor Vehicle Safety Regulations*.

S4. Definition

Stop signal arm means a device that can be extended outward from the side of a school bus to provide a signal to other motorists not to pass the bus because it has stopped to load or discharge passengers. (*Bras d'arrêt*)

S5. Requirements

Each school bus shall be equipped with a stop signal arm meeting the requirements of S5.1 through S5.5, as depicted in Figure 1.

S5.1 The stop signal arm shall be a regular octagon which is at least 450 mm x 450 mm (17.72 inches x 17.72 inches) in diameter.

S5.2 The stop signal arm shall be red on both sides, except as provided in S5.2.1, ~~and~~ S5.2.2, and S5.2.3.

S5.2.1 The stop signal arm shall have a white border at least 12 mm (0.47 inches) wide on both sides, except as provided in S5.2.3. Mounting brackets, clips, bolts, or other components necessary to the mechanical or electrical operation of the stop signal arm may not obscure more than 15 percent of the border on each side of the stop arm. The portion of

the border that may be obscured is in addition to that portion which may be obscured by the two red lamps specified in S5.3.2.

- (2) **S5.2.2** The stop signal arm shall have the word “STOP” displayed in white upper-case letters on both sides, except as provided in S5.2.3. The letters shall be at least 150 mm (5.9 inches) in height. The letters shall have a stroke width of at least 20 mm (0.79 inches), except as provided in S.5.3.1.1.

S5.2.3 When two stop signal arms are installed on a school bus, the rearmost stop signal arm shall not contain any lettering, symbols, or markings on the forward side.

S5.3 Conspicuity. The stop signal arm shall comply with either S5.3.1 or S5.3.2, or both.

S5.3.1 Except as provided in S5.3.1.1, S5.3.1.2, or S5.3.1.3, the entire surface of both sides of the stop signal arm shall be reflectorized with type III retroreflectorized material that meets the minimum specific intensity requirements of S6.1 and Table 1.

S.5.3.1.1 The legend of the retroreflective stop arm may be illuminated in a manner such that light is emitted from the surface of each letter or from the area immediately surrounding each letter. Only red lamps may be used. They shall form the complete shape of each letter of the legend, and shall be affixed to all letters (or to the areas immediately surrounding all letters) in the legend. The shape of each letter shall remain constant and, if the lamps are contained within each letter, the net stroke width (stroke width minus the width of the lamp(s)) of each letter of the legend, specified in S5.2.2, shall not be less than 15 mm (0.59 inch). When the stop arm is extended, the lamps shall flash at the rate specified in S6.2.2, with a current “on” time specified in S6.2.2.1. All lamps shall be positioned in one of the two following ways:

- (1) centered within the stroke of each letter of the legend, or
- (2) outlining each letter of the legend.

S5.3.1.2 Nonreflectorized mounting brackets, clips, bolts, or other components necessary to the mechanical or electrical operation of the stop signal arm shall not obscure more than 7.5 percent of the total surface area of either side of the stop signal arm.

S5.3.1.3 When two stop signal arms are installed on a school bus, the forward side of the rearmost stop signal arm shall not be reflectorized.

S5.3.2 Each side of the stop signal arm shall have at least two red lamps that meet the requirements of S6.2. The lamps shall be centered on the vertical centerline of the stop arm. One of the lamps shall be located at the extreme top of the stop arm and the other at its extreme bottom.

S5.4 The stop signal arm shall be installed on the left side of the bus.

S5.4.1 The stop signal arm shall be located such that, when in the extended position:

- (a) The stop signal arm is perpendicular to the side of the bus, plus or minus five degrees;
- (b) The top edge of the stop signal arm is parallel to and not more than 150 mm (6 inches) from a horizontal plane tangent to the lower edge of the frame of the passenger window immediately behind the driver’s window; and

(c) The vertical centerline of the stop signal arm is not less than 230 mm (9 inches) away from the side of the school bus.

S5.4.2 A second stop signal arm may be installed on a school bus. That stop signal arm shall comply with S5.4 and S5.4.1.

S5.5 The stop signal arm shall be automatically extended in such a manner that it complies with S5.4.1, at a minimum whenever the red signal lamps required by S5.1.4 of TSD Standard No. 108 are activated, except that a device may be installed that prevents the automatic extension of a stop signal arm. The mechanism for activating the device shall be within the reach of the driver. While the device is activated, a continuous or intermittent signal audible to the driver shall sound. The audible signal may be equipped with a timing device requiring the signal to sound for at least 60 seconds. If a timing device is used, it shall automatically recycle every time the service entry door is opened while the engine is running and the manual override is engaged.

S6. Test Procedures

S6.1 Reflectivity Test. When tested under the conditions specified in S6.2 (b), (c), and (d) of Federal motor vehicle safety standard 125, Warning Devices, (49 CFR 571.125), the retroreflective materials shall meet the criteria specified in Table 1.

**TABLE 1: MINIMUM SPECIFIC INTENSITY PER UNIT AREA
(cd/lx/m²) (Candela per Foot-candle per Square Foot)**

Observation Angle (°)	Entrance Angle (°)	White	Red
Type III Retroreflective Element Material A-Glass Bead Retroreflective Element Material			
0.2	- 4	250	45
0.2	+ 30	150	25
0.5	- 4	95	15
0.5	+ 30	65	10
B-Prismatic Retroreflective Element Material			
0.2	- 4	250	45
0.2	+ 30	95	13.3
0.5	- 4	200	28
0.5	+ 30	65	10

S6.2 Lighting Tests

S6.2.1 Color. The procedure shall be done in accordance with the Society of Automotive Engineers (SAE) J578, *Color Specification* (May 1988), 1990 SAE Handbook, Society of Automotive Engineers, Inc. ~~Along with the incorporation by reference in S6.2.3, this incorporation by reference was approved by the Director of the Federal Register in accordance with 5 U.S.C. 552(a) and 1 CFR part 51.~~ Copies may be obtained from the Society of Automotive Engineers, 400 Commonwealth Drive, Warrendale, PA 15096-0001. ~~Copies may be inspected at Docket Room, National Highway Traffic Safety Administration,~~

~~400 Seventh Street, S.W., Washington, DC 20590 or at the Office of the Federal Register, 1100 L Street, N.W., room 8401, Washington, D.C.~~ When visually compared to the light emitted from a filter/source with a combination of chromaticity coordinates as explained in SAE J578, *Color Specification* (May 1988), within specific boundaries [$y = 0.33$ (yellow boundary) and $y = 0.98 - x$ (purple boundary)] the color of light emitted from the test object shall not be less saturated (paler), yellower, or purpler. The test object shall be placed perpendicular to the light source to simulate lamps on stop signal arms. In making visual comparisons, the light from the test object shall light one portion of a comparison field and the light from the filter/source standard shall light an adjacent area. To make a valid visual comparison, the two fields to be viewed shall be of near equal luminance.

S6.2.2 Flash rate. The lamps on each side of the stop signal arm, when operated at the manufacturer's design load, shall flash alternately at a rate of 60 to 120 flashes per minute.

S6.2.2.1 Lamps, except those subject to S6.2.2.2, shall have a current "on" time of 30 to 75 percent of the total flash cycle. The total current "on" time for the two terminals shall be between 90 and 110 percent of the total flash cycle.

S6.2.2.2 Xenon short-arc gaseous discharge lamps shall have an "off" time before each flash of at least 50 percent of the total flash cycle.

S6.2.3 Vibration, Moisture, Dust, Corrosion, Photometry, and Warpage Tests. The procedure shall be done in accordance with the Society of Automotive Engineers (SAE) J575, *Tests for Motor Vehicle Lighting Devices and Components*, (July 1983) and Society of Automotive Engineers (SAE) J1133, *School Bus Stop Arm*, (April 1984), 1990 SAE Handbook, Society of Automotive Engineers, Inc. Lamps and lighting components shall meet the criteria for vibration, moisture, dust, corrosion, photometry, and warpage in SAE J575, *Tests for Motor Vehicle Lighting Devices and Components*, (July 1983) and SAE J1133, *School Bus Stop Arm*, (April 1984), under the test conditions specified herein.

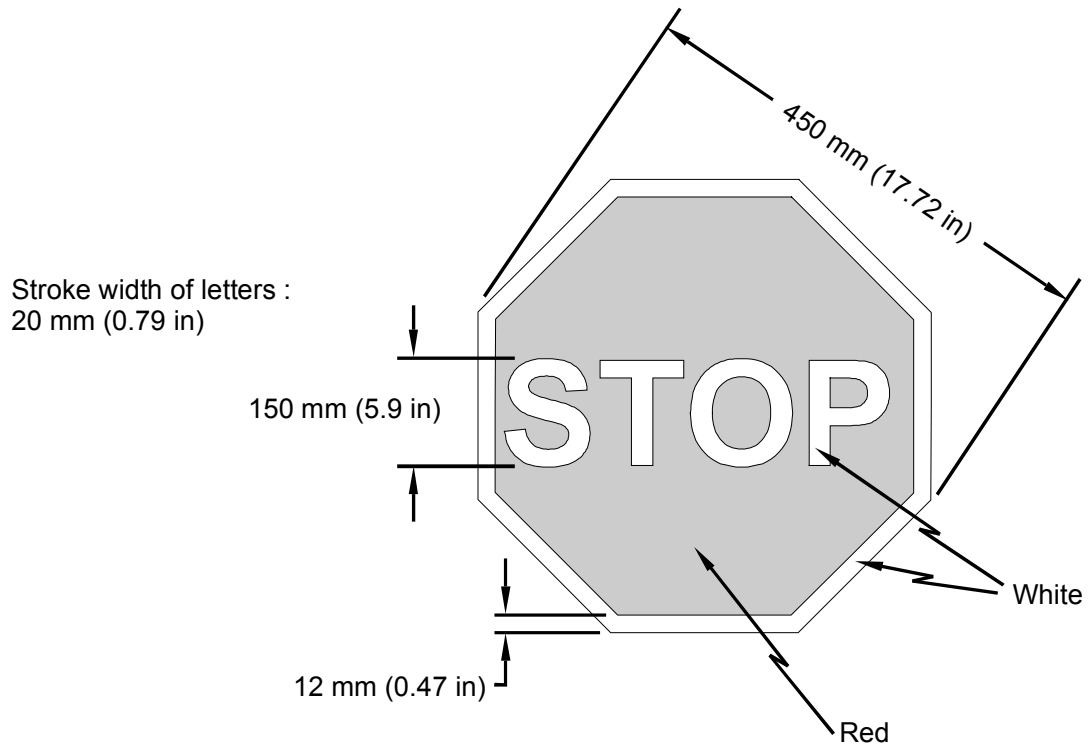

Figure 1: Characteristics of Stop Signal Device