



Transport Canada
Safety and Security

Transports Canada
Sécurité et sûreté

Road Safety

Sécurité routière

Standards and Regulations Division

TECHNICAL STANDARDS DOCUMENT

No. 301, Revision 0

Fuel System Integrity

The text of this document is based on the U.S. *Code of Federal Regulations*, Title 49, Part 571, Federal Motor Vehicle Safety Standard No. 301, Fuel System Integrity, revised as of October 1, 2002, including the Final Rule published in the *Federal Register* on July 29, 2003 (Vol. 68, No. 145, p. 44468) and the Final Rule published in the *Federal Register* on December 1, 2003 (Vol. 68, No. 230, p. 67068).

Effective Date: April 22, 2004
Mandatory Compliance Date: November 5, 2004

Standards Research and Development Branch
Road Safety and Motor Vehicle Regulation Directorate
TRANSPORT CANADA
Ottawa, Ontario
K1A 0N5

Technical Standards Document Number 301, Revision 0

Fuel System Integrity

(Ce document est aussi disponible en français.)

Introduction

As defined by section 12 of the *Motor Vehicle Safety Act*, a Technical Standards Document (TSD) is a document that reproduces an enactment of a foreign government (e.g. a Federal Motor Vehicle Safety Standard issued by the U.S. National Highway Traffic Safety Administration). According to the Act, the *Motor Vehicle Safety Regulations* may alter or override some provisions contained in a TSD or specify additional requirements; consequently, it is advisable to read a TSD in conjunction with the Act and its counterpart Regulation. As a guide, where modifications have been made, the corresponding clause number is indicated in the margin of the TSD within parentheses.

TSDs are revised from time to time in order to incorporate amendments made to the reference document, at which time a Notice of Revision is published in the *Canada Gazette*, Part I. All TSDs are assigned a revision number, with “Revision 0” designating the original version.

Identification of Changes

In order to facilitate the incorporation of a TSD, certain non-technical changes may be made to the foreign enactment. These may include the deletion of words, phrases, figures, or sections that do not apply under the Act or Regulations, the conversion of imperial to metric units, the deletion of superseded dates, and minor changes of an editorial nature. Additions are underlined, and provisions that do not apply are ~~stroked through~~. Where an entire section has been deleted, it is replaced by: “[CONTENT DELETED]”. Changes are also made where there is a reporting requirement or reference in the foreign enactment that does not apply in Canada. For example, the name and address of the U.S. Department of Transportation are replaced by those of the Department of Transport.

Effective Date and Mandatory Compliance Date

Compliance with the requirements of a TSD that is being introduced for the first time is not mandatory until six months after publication in the *Canada Gazette*, Part II, of the Regulations that incorporate the TSD. In the case of a revision, compliance becomes mandatory six months after publication of the Notice of revision in the *Canada Gazette*, Part I, as long as the requirements of the previous version continue to be met. Voluntary compliance is permitted as of the Effective Date of the TSD.

Official Version of Technical Standards Documents

Technical Standards Documents may be consulted electronically in both HTML and Portable Document Format (PDF) on the Department of Transport's Web site at www.tc.gc.ca/RoadSafety/mvstm_tsd/index_e.htm. The PDF version is a replica of the TSD as published by the Department and is to be used for the purposes of legal interpretation and application. The HTML version is provided for information purposes only.

(Original signed by)

Director, Standards Research and Development
for the Minister of Transport,
Ottawa, Ontario

TABLE OF CONTENTS**Technical Standards Document
Number 301, Revision 0****FUEL SYSTEM INTEGRITY**

<i>Introduction</i>	<i>i</i>
<i>S1. Scope</i>	<i>1</i>
<i>S2. Purpose</i>	<i>1</i>
<i>S3. Application</i>	<i>1</i>
<i>S4. Definition</i>	<i>1</i>
<i>S5. General requirements</i>	<i>1</i>
<i>S6. Test requirements</i>	<i>2</i>
<i>S7. Test conditions</i>	<i>3</i>

TABLE OF FIGURES

<i>Figure 1 — Common Carriage for Moving Barriers</i>	<i>7</i>
<i>Figure 2 — Common Carriage With Contoured Impact Surface Attached</i>	<i>8</i>
<i>Figure 3 — Moving Deformable Barrier Rear Impact, 70% Overlap</i>	<i>9</i>

**Technical Standards Document
Number 301, Revision 0**

FUEL SYSTEM INTEGRITY

The text of this document is based on the U.S. *Code of Federal Regulations*, Title 49, Part 571, Federal Motor Vehicle Safety Standard No. 301, Fuel System Integrity, revised as of October 1, 2002, including the Final Rule published in the *Federal Register* on July 29, 2003 (Vol. 68, No. 145, p. 44468) and the Final Rule published in the *Federal Register* on December 1, 2003 (Vol. 68, No. 230, p. 67068).

S1. Scope

This Technical Standards Document (TSD) standard specifies requirements for the integrity of motor vehicle fuel systems.

S2. Purpose

The purpose of this TSD standard is to reduce deaths and injuries occurring from fires that result from fuel spillage during and after motor vehicle crashes and resulting from ingestion of fuels during siphoning.

(1) **S3. Application**

(2) [CONTENT DELETED] For applicability, see Schedule III and section 301 of Schedule IV to the *Motor Vehicle Safety Regulations*.

S4. Definition

Fuel spillage means the fall, flow, or run of fuel from the vehicle but does not include wetness resulting from capillary action. (*Écoulement de carburant*)

S5. General requirements

S5.1 Passenger cars, and multipurpose passenger vehicles, trucks, and buses with a GVWR of 4,536 kg (10,000 pounds) or less. Each passenger car and each multipurpose passenger vehicle, truck, and bus with a GVWR of 4,536 kg (10,000 pounds) or less shall meet the requirements of S6.1 through S6.4. Each of these types of vehicles that is manufactured to use alcohol fuels shall also meet the requirements of S6.6.

S5.2 [Reserved]

S5.3 [Reserved]

S5.4 School buses with a GVWR greater than 4,536 kg (10,000 pounds). Each school bus with a GVWR greater than 4,536 kg (10,000 pounds) shall meet the requirements of

S6.5. In addition, each school bus with a GVWR greater than 4,536 kg (10,000 pounds) that is manufactured to use alcohol fuels shall meet the requirements of S6.6.

S5.5 Fuel spillage: Barrier crash. Fuel spillage in any fixed or moving barrier crash test shall not exceed 28 g from impact until motion of the vehicle has ceased, and shall not exceed a total of 142 g in the 5-minute period following cessation of motion. For the subsequent 25-minute period, fuel spillage during any 1-minute interval shall not exceed 28 g.

S5.6 Fuel spillage: Rollover. Fuel spillage in any rollover test, from the onset of rotational motion, shall not exceed a total of 142 g for the first 5 minutes of testing at each successive 90° increment. For the remaining test period, at each increment of 90°, fuel spillage during any 1-minute interval shall not exceed 28 g.

S5.7 Alcohol-fuelled vehicles. Each vehicle manufactured to operate on an alcohol fuel (e.g., methanol, ethanol) or a fuel blend containing at least 20 percent alcohol fuel shall meet the requirements of S6.6.

S6. Test requirements

Each vehicle with a GVWR of 4,536 kg or less shall be capable of meeting the requirements of any applicable barrier crash test followed by a static rollover, without alteration of the vehicle during the test sequence. A particular vehicle need not meet further requirements after having been subjected to a single barrier crash test and a static rollover test.

S6.1 Frontal barrier crash. When the vehicle travelling longitudinally forward at any speed up to and including 48 km/h impacts a fixed collision barrier that is perpendicular to the line of travel of the vehicle, or at any angle up to 30° in either direction from the perpendicular to the line of travel of the vehicle, with 50th percentile test dummies as specified in the U.S. Code of Federal Regulations (CFR), Title 49, Part 572 (hereinafter referred to as 49 CFR, Part 572) of this chapter at each front outboard designated seating position and at any other position whose protection system is required to be tested by a dummy under the provisions of Standard No. 208 of Title 49, Part 571 of the CFR (hereinafter referred to as 49 CFR 571.208), under the applicable conditions of S7, fuel spillage shall not exceed the limits of S5.5.

(3) **S6.2 Rear moving barrier crash**

(a) *Vehicles manufactured before September 1, ~~2009~~ 2006.* When the vehicle is impacted from the rear by the barrier specified in S7.3(a) of this TSD standard moving at 48 km/h, with 50th percentile test dummies as specified in 49 CFR, Part 572 of this chapter at each front outboard designated seating position, under the applicable conditions of S7, fuel spillage must not exceed the limits of S5.5.

(b) *Vehicles manufactured on or after September 1, ~~2009~~ 2006.* When the vehicle is impacted from the rear by a moving deformable barrier at 80 km/h \pm 1.0 km/h with a 70 percent overlap, with 50th percentile test dummies as specified in 49 CFR, Part 572 of

~~this chapter~~ at each front outboard designated seating position, under the applicable conditions of S7, fuel spillage must not exceed the limits of S5.5.

(3) **S6.3 Side moving barrier crash**

(a) *Vehicles manufactured before September 1, ~~2009~~ 2004.* When the vehicle is impacted laterally on either side by a barrier moving at 32 km/h with 50th percentile test dummies as specified in ~~49 CFR, Part 572 of this chapter~~ at positions required for testing to standard No. 208 (49 CFR 571.208), under the applicable conditions of S7, fuel spillage must not exceed the limits of S5.5.

(b) *Vehicles manufactured on or after September 1, ~~2009~~ 2004.* When the vehicle is impacted laterally on either side by a moving deformable barrier at 53 km/h \pm 1.0 km/h with 49 CFR, Part 572, subpart F test dummies at positions required for testing by S3(b) of Standard No. 214 of Title 49, Part 572 of the CFR (hereinafter referred to as 49 CFR 571.214), under the applicable conditions of S7 of this TSD standard, fuel spillage shall not exceed the limits of S5.5 of this TSD standard.

S6.4 Static rollover. When the vehicle is rotated on its longitudinal axis to each successive increment of 90°, following an impact crash of S6.1, S6.2, or S6.3, fuel spillage shall not exceed the limits of S5.6.

S6.5 Moving contoured barrier crash. When the moving contoured barrier assembly travelling longitudinally forward at any speed up to and including 48 km/h impacts the test vehicle (school bus with a GVWR exceeding 4,536 kg) at any point and angle, under the applicable conditions of S7.1 and S7.5, fuel spillage shall not exceed the limits of S5.5.

S6.6 Anti-siphoning test for alcohol-fuelled vehicles. Each vehicle shall have means that prevents any hose made of vinyl plastic or rubber, with a length of not less than 1,200 millimeters (mm) and an outside diameter of not less than 5.2 mm, from contacting the level surface of the liquid fuel in the vehicle's fuel tank or fuel system, when the hose is inserted into the filler neck attached to the fuel tank with the fuel tank filled to any level from 90 to 95 percent of capacity.

S7. Test conditions

The requirements of S5.1 through S5.6 and S6.1 through S6.5 shall be met under the following conditions. Where a range is specified, the vehicle must be capable of meeting the requirements at all points within the range.

S7.1 General test conditions. The following conditions apply to all tests.

S7.1.1 The fuel tank is filled to any level from 90 to 95 percent of capacity with Stoddard solvent, having the physical and chemical properties of type 1 solvent as specified in Table I of American Society for Testing and Materials (ASTM) Standard D 484-71, *Standard Specifications for Hydrocarbon Dry Cleaning Solvents*.

S7.1.2 The fuel system other than the fuel tank is filled with Stoddard solvent to its normal operating level.

S7.1.3 In meeting the requirements of S6.1 through S6.3, if the vehicle has an electrically driven fuel pump that normally runs when the vehicle's electrical system is activated, it is operating at the time of the barrier crash.

S7.1.4 The parking brake is disengaged and the transmission is in neutral, except that in meeting the requirements of S6.5 the parking brake is set.

S7.1.5 Tires are inflated to manufacturer's specifications.

S7.1.6 The vehicle, including test devices and instrumentation, is loaded as follows:

- (a) Except as specified in S7.1.1, a passenger car is loaded to its unloaded vehicle mass weight plus its rated cargo and luggage capacity mass weight, secured in the luggage area, plus the necessary test dummies as specified in S6, restrained only by means that are installed in the vehicle for protection at its seating position.
- (b) Except as specified in S7.1.1, a multipurpose passenger vehicle, truck, or bus with a GVWR of 4,536 kg or less is loaded to its unloaded vehicle mass weight, plus the necessary test dummies, as specified in S6, plus 136 kg or its rated cargo and luggage capacity mass weight, whichever is less, secured in the load carrying area and distributed as nearly as possible in proportion to its GAWR. For the purpose of this TSD standard, unloaded vehicle mass weight does not include the mass weight of work-performing accessories. Each dummy is restrained only by means that are installed in the vehicle for protection at its seating position.
- (4) (c) Except as specified in S7.1.1, a school bus with a GVWR greater than 4,536 kg is loaded to its unloaded vehicle mass weight, plus 55 54 kg of unsecured mass at each designated seating position.

S7.2 Side moving barrier test conditions

- (a) *Vehicles manufactured before September 1, ~~2009~~ 2004.* The side moving barrier crash test conditions are those specified in S8.2 of Standard No. 208 (49 CFR 571.208).
- (b) *Vehicles manufactured on or after September 1, ~~2009~~ 2004.* The side moving deformable barrier crash test conditions are those specified in S6 and S7 of Standard No. 214 (49 CFR 571.214).

S7.3 Rear moving barrier test conditions

- (a) *Vehicles manufactured before September 1, ~~2009~~ 2006.* The rear moving barrier test conditions are those specified in S8.2 of Standard No. 208 (49 CFR 571.208), except for the positioning of the barrier and the vehicle. The barrier and the test vehicle are positioned so that at impact:

- (1) The vehicle is at rest in its normal attitude;
 - (2) The barrier is travelling at 48 km/h with its face perpendicular to the longitudinal centerline of the vehicle; and
 - (3) A vertical plane through the geometric center of the barrier impact surface and perpendicular to that surface coincides with the longitudinal centerline of the vehicle.
- (b) *Vehicles manufactured on or after September 1, ~~2009~~ 2006.* The rear moving deformable barrier is the same as that shown in Figure 2 of Standard No. 214 (49 CFR 571.214) and specified in 49 CFR, Part 587, except as otherwise specified in paragraph S7.3(b). The barrier and test vehicle are positioned so that at impact:
- (1) The test vehicle is stationary;
 - (2) The deformable face of the barrier is mounted on the barrier 50 mm (2 inches) lower than the height from the ground specified in Figure 2 of Standard No. 214 (49 CFR 571.214). (All dimensions from the ground in Figure 2, Front View and Side View, should be reduced by 50 mm [2 inches].);
 - (3) The barrier is traveling at 80 km/h \pm 1.0 km/h; and
 - (4) The barrier impacts the test vehicle with the longitudinal centerline of the vehicle parallel to the line of travel and perpendicular to the barrier face within a tolerance of \pm 5 degrees. The test vehicle and barrier face are aligned so that the barrier strikes the rear of the vehicle with 70 percent overlap toward either side of the vehicle. So aligned, the barrier face fully engages one-half of the rear of the vehicle and partially engages the other half. At impact, the vehicle's longitudinal centerline is located inboard of either of the side edges of the barrier by a distance equal to 20 percent of the vehicle's width \pm 50 mm (*see* Figure 3). The vehicle's width is the maximum dimension measured across the widest part of the vehicle, including bumpers and molding, but excluding such components as exterior mirrors, flexible mud flaps, marker lamps, and dual rear-wheel configurations.

S7.4 Static rollover test conditions. The vehicle is rotated about its longitudinal axis, with the axis kept horizontal, to each successive increment of 90°, 180°, and 270° at a uniform rate, with 90° of rotation taking place in any time interval from 1 to 3 minutes. After reaching each 90° increment, the vehicle is held in that position for 5 minutes.

S7.5 Moving contoured barrier test conditions. The following conditions apply to the moving contoured barrier crash test.

S7.5.1 The moving contoured barrier, which is mounted on a carriage as specified in Figure 1, is of rigid construction, symmetrical about a vertical longitudinal plane. The contoured impact surface, which is 629 mm high and 1,981 mm wide, conforms to the dimensions shown in Figure 2 and is attached to the carriage as shown in that figure. The

ground clearance to the lower edge of the impact surface is $133 \text{ mm} \pm 13 \text{ mm}$. The wheelbase is $3,048 \text{ mm} \pm 50 \text{ mm}$.

S7.5.2 The moving contoured barrier, including the impact surface, supporting structure, and carriage, has a mass of $1,814 \text{ kg} \pm 23 \text{ kg}$ with the mass distributed so that $408 \text{ kg} \pm 11 \text{ kg}$ is at each rear wheel and $499 \text{ kg} \pm 11 \text{ kg}$ is at each front wheel. The center of gravity is located $1,372 \text{ mm} \pm 38 \text{ mm}$ rearward of the front wheel axis, in the vertical longitudinal plane of symmetry, $401 \text{ mm} \pm 13 \text{ mm}$ above the ground.

S7.5.3 The moving contoured barrier has a solid nonsteerable front axle and fixed rear axle attached directly to the frame rails with no spring or other type of suspension system on any wheel. (The moving barrier assembly is equipped with a braking device capable of stopping its motion.)

S7.5.4 The concrete surface upon which the vehicle is tested is level, rigid, and of uniform construction, with a skid number of 75 when measured in accordance with American Society of Testing and Materials Method E: 274-65T at 64 km/h, omitting water delivery as specified in paragraph 7.1 of that method.

S7.5.5 The barrier assembly is released from the guidance mechanism immediately prior to impact with the vehicle.

S7.6 The moving barrier assemblies specified in S7.2, S7.3, and S7.5 are equipped with P205/75R15 pneumatic tires inflated to $200 \text{ kPa} \pm 21 \text{ kPa}$.

S8. [CONTENT DELETED]

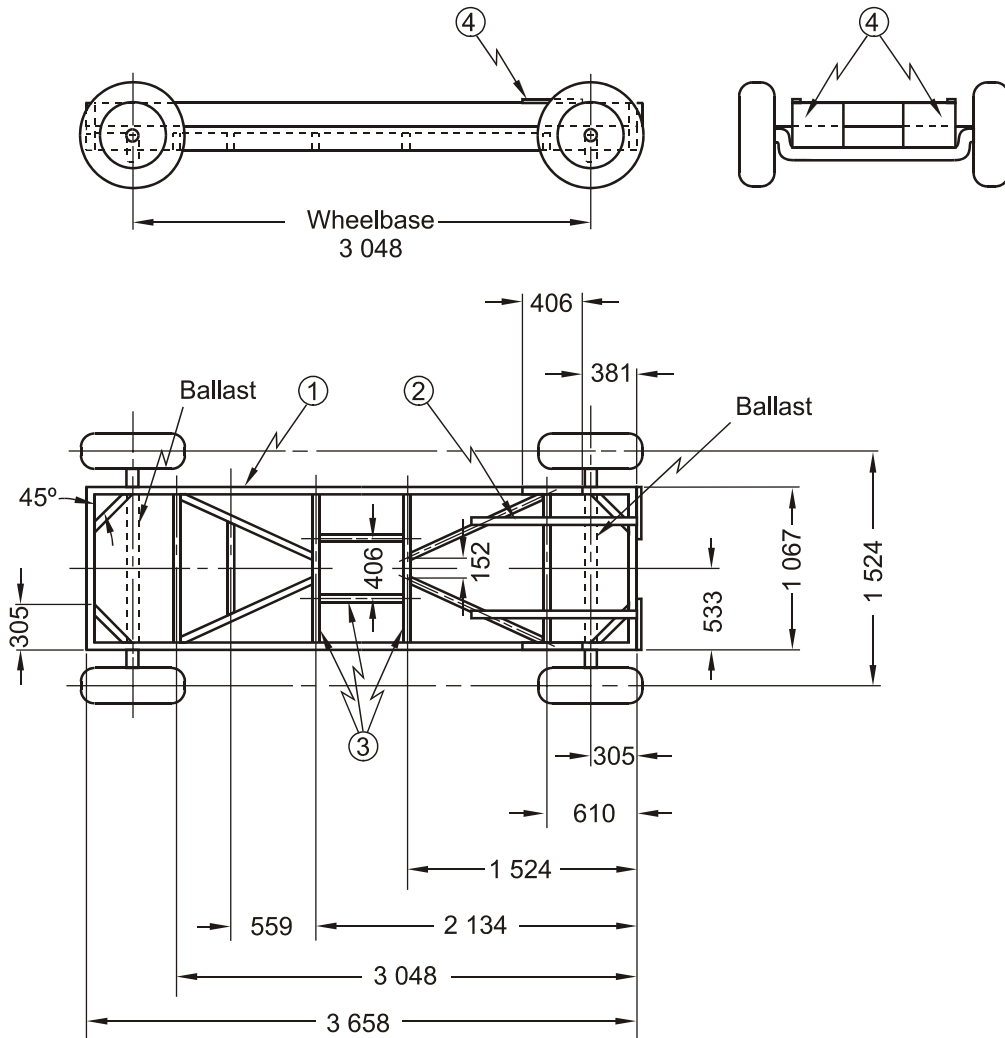

Notes:

1. Dimensions in mm
2. Drawing not to scale
3. Bullets:
 - 1 Outer frame 152 x 51 x 5 steel tubing, two pieces welded together for a height of 305
 - 2 Ballast tie downs
 - 3 All inner reinforcements and frame gussets of 102 x 51 x 5 steel tubing
 - 4 Reinforced areas for bolting on face plates

Figure 1 — Common Carriage for Moving Barriers

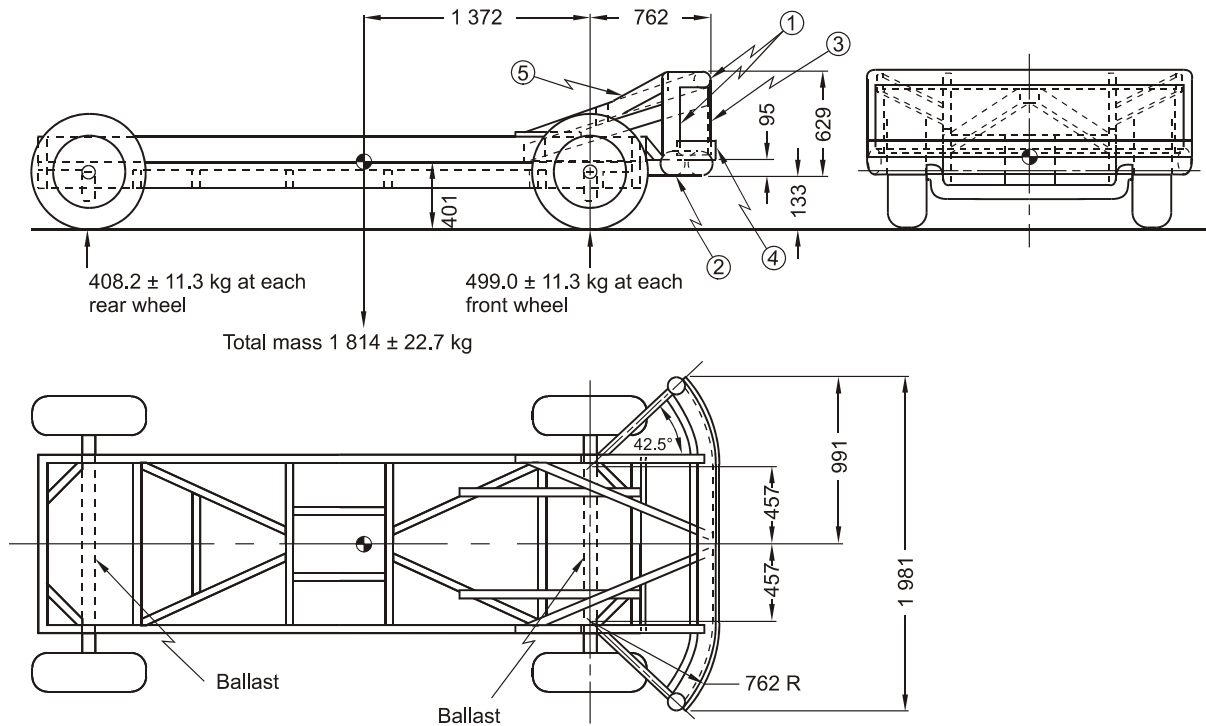

Notes:

1. Dimensions in mm
2. Not to scale
3. Bullets:
 - 1 Upper frame 102 ϕ x 6 wall steel tubing (three sides)
 - 2 Lower frame 152 ϕ x 13 wall steel tubing
 - 3 Face plate 19 thick cold rolled steel
 - 4 Leading edge 25 x 102 steel band, sharp edges broken
 - 5 All inner reinforcements 102 x 51 x 5 steel tubing

Figure 2 — Common Carriage With Contoured Impact Surface Attached

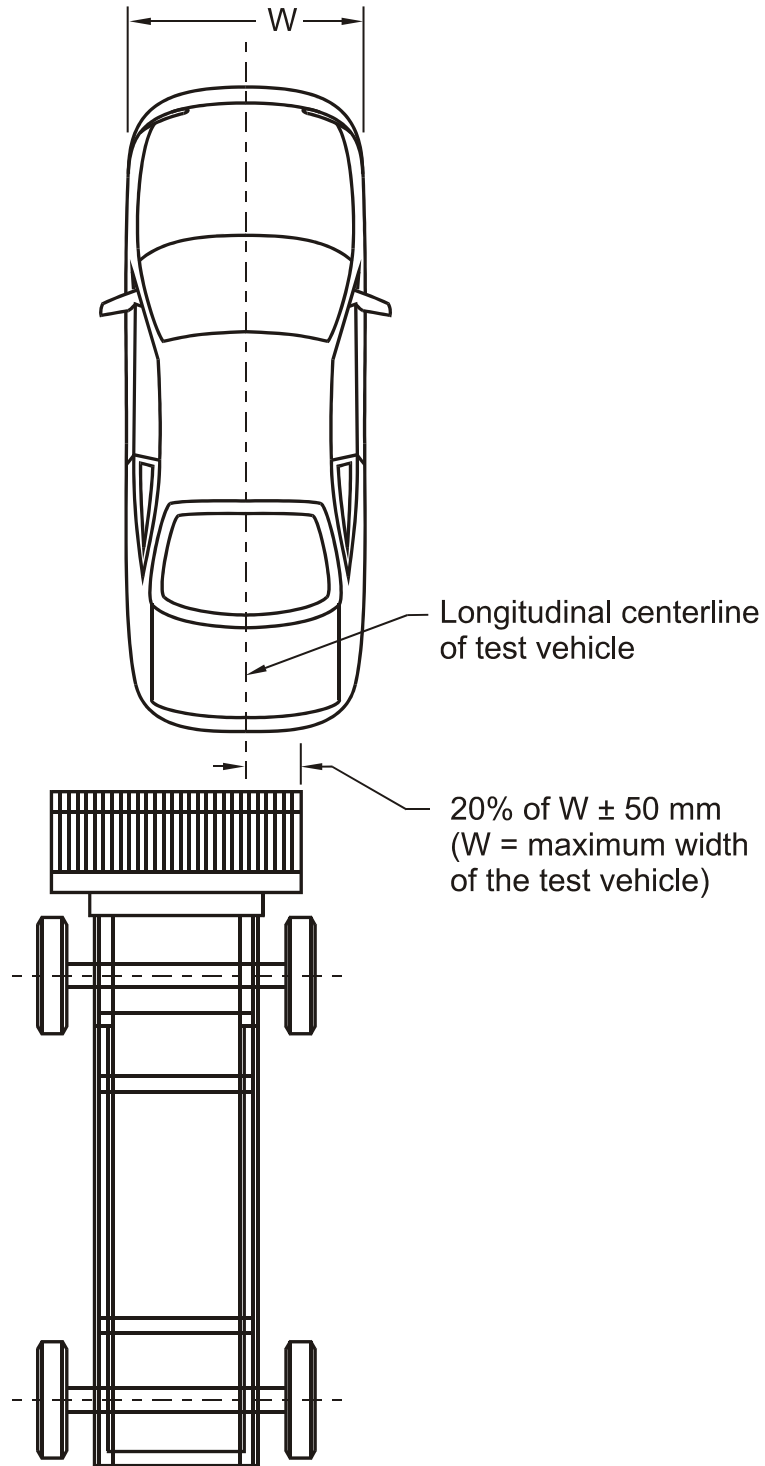

Moving deformable barrier
(Impact velocity = 80 km/h ± 1 km/h)

Figure 3 — Moving Deformable Barrier Rear Impact, 70% Overlap