

Safe ladder use

When climbing up or down, workers should:

- Always face the ladder.
- Use a three-point contact climbing method (two hands and one foot or one hand and two feet).

Only one worker at a time is allowed on a single-width ladder.



Workers must not use ladder-type material hoists for roof access unless the hoists are designed for that purpose.



Workers must not work from the top two rungs of a ladder.

Heavy, bulky, or hazardous materials must not be carried when climbing ladders. Suitable hoisting equipment must be used for this purpose.



Safe ladder use

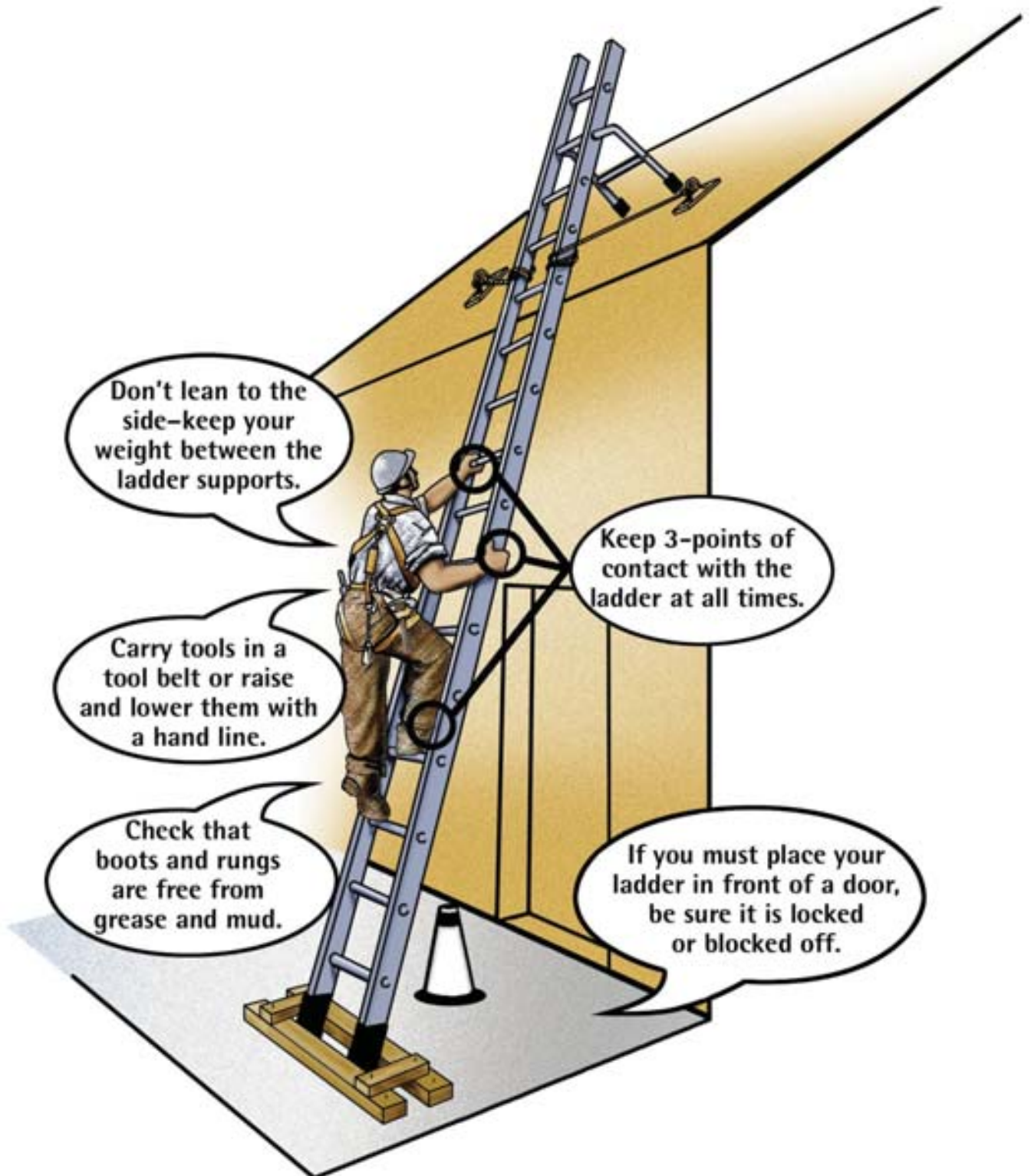

Setting up a ladder

Inspect each ladder before use. Ladders with loose, broken, or missing rungs, split or bent side rails, or other defects must be identified and removed from service.

Only use CSA or ANSI Standard approved heavy duty ladders or job-constructed wooden ladders built to WCB Standard: LDR 1-2004.

Ladder tops must rest against a firm structure.

Ladders (other than stepladders) must extend approximately 1 m (3 ft) above a safe landing or parapet wall.

Ladders must be set up with a 4 vertical to 1 horizontal slope.

Ladders must be tied, blocked, or otherwise secured to prevent them from slipping.

The base of a ladder's side rails must rest on a firm, level foundation.

Watch for overhead power lines before erecting a ladder. Metal, including wire-reinforced wooden ladders, must not be used near energized electrical conductors.

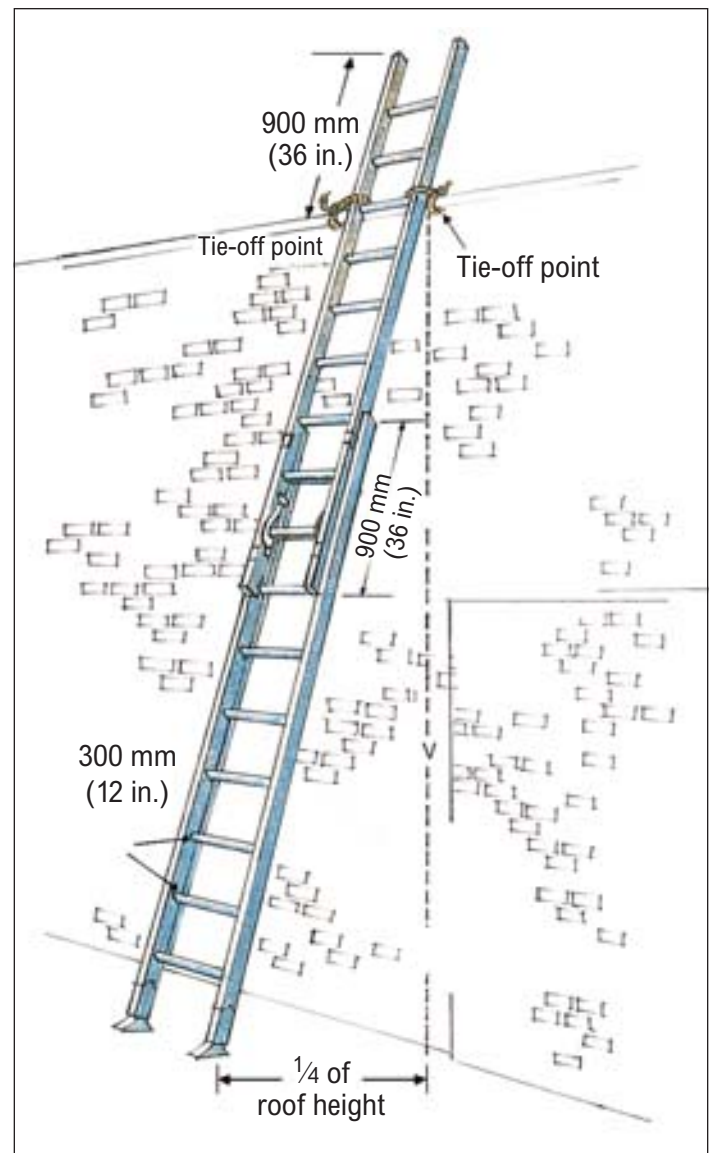

Setting up a ladder

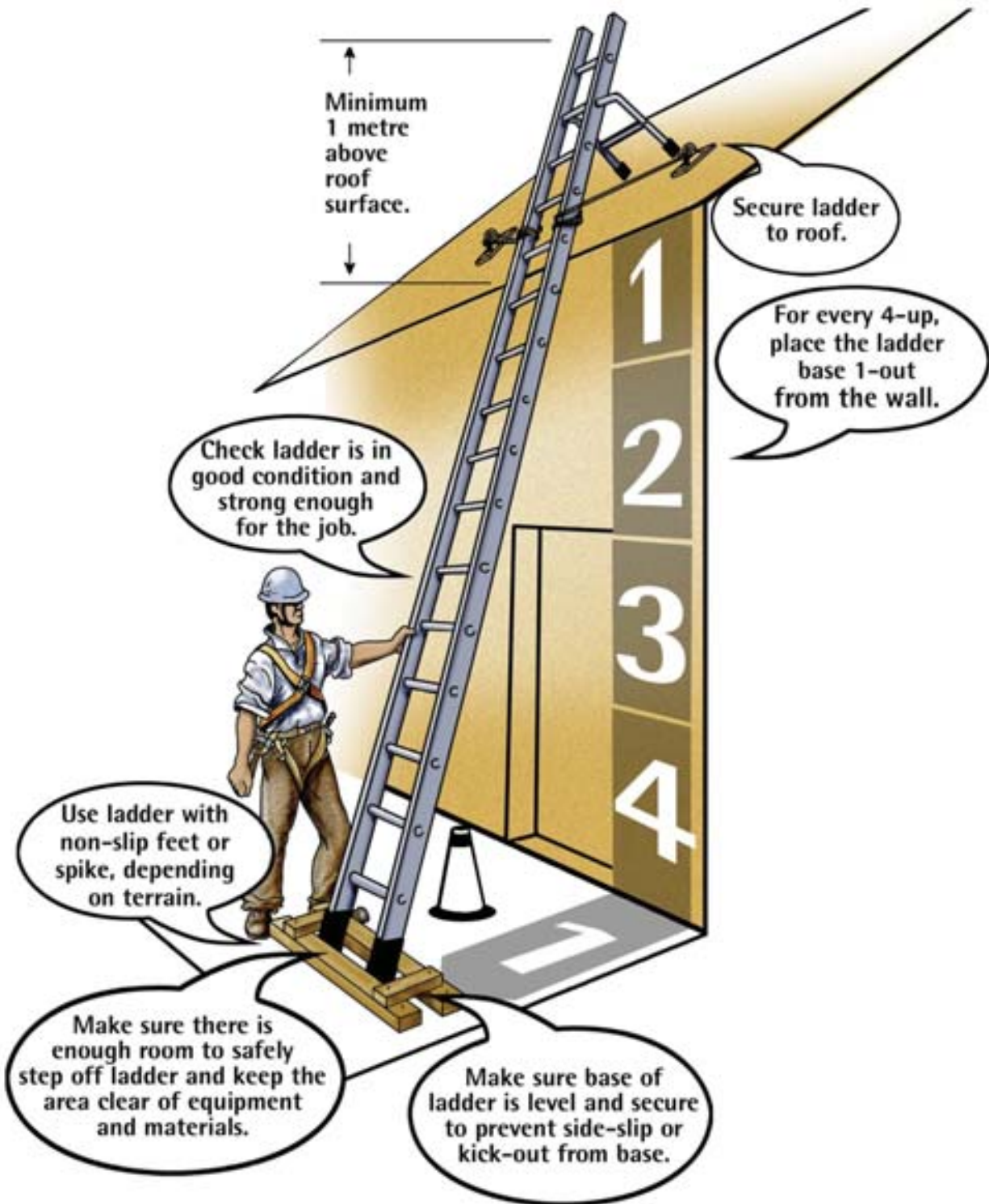

Job-built ladders

Job-constructed wooden ladders must be designed and built to the following WCB specifications.

NOTE: The specifications shown here are for ladders up to a maximum of 5 m (16 ft.) in length.

- All ladder components must be cut from lumber free of defects, and must be construction grade or better.
- The side rails must be 38 mm x 89 mm (2 in. x 4 in. nominal) dimensions. Side rails must not be notched, dapped, tapered, or spliced. The distance between the inner face of side rails must not be less than 380 mm (15 in.) nor more than 500 mm (20 in.).
- The rungs (cleats) must be 19 mm x 64 mm (1 x 3 in. nominal) dimensions. Rungs must be placed at 300 mm (12 in.) centres.
- Rungs must be nailed directly onto the edge of the side rails.

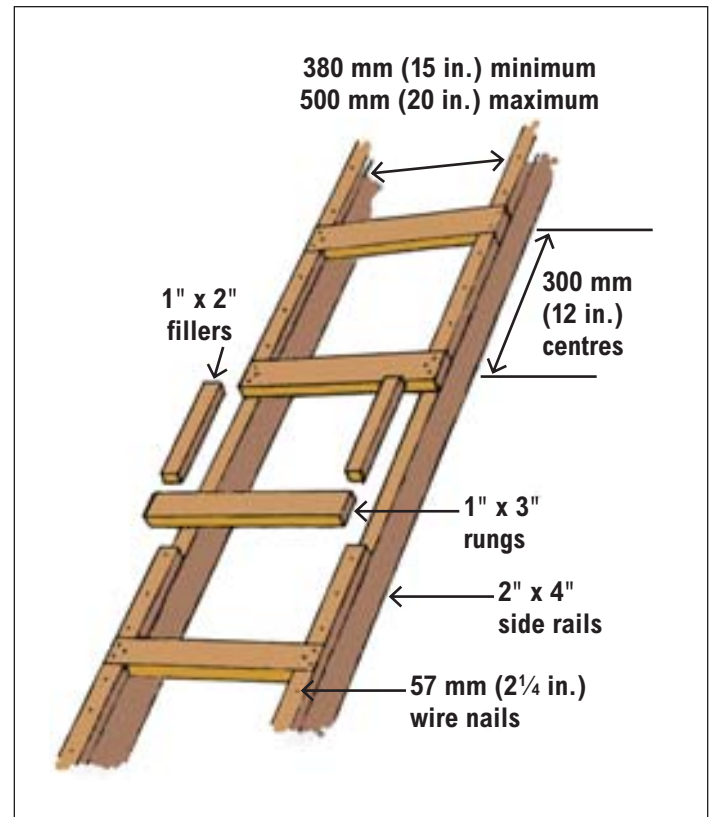

A job-built ladder up to 5 m (16 ft.) long.

Stepladder use



Extension ladder use

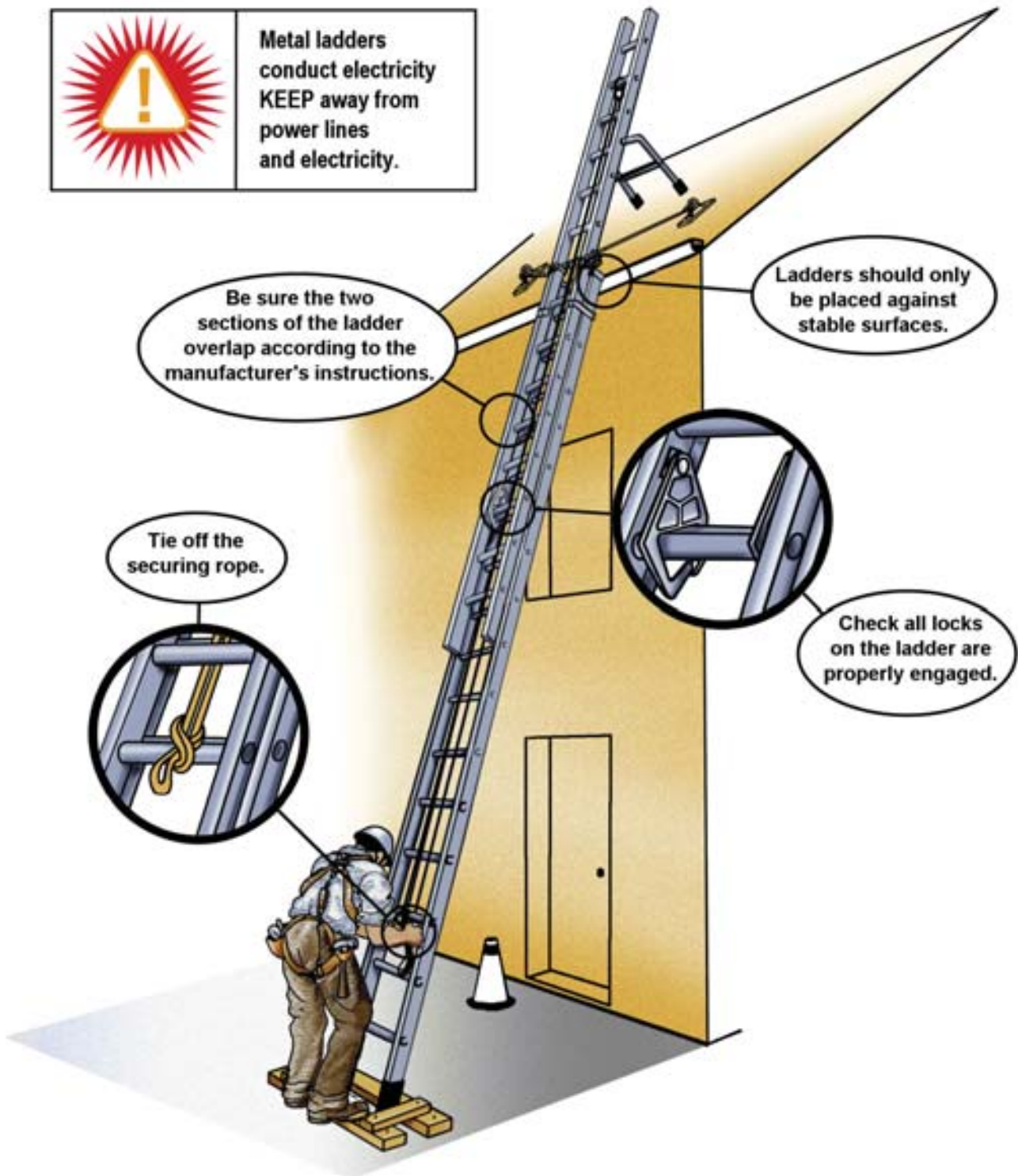

Stairway landings, ramps, and walkways

Stairways complete with handrails must be installed before beginning work on the next floor level.

Stairway landings, ramps, and walkways that are 1.2 m (4 ft.) or more above grade must have guardrails.

Workers must be prevented from falling when working 3 m (10 ft.) or more above grade. Standard guardrails or fall protection equipment must be used for this purpose.



Temporary stairways with handrails.

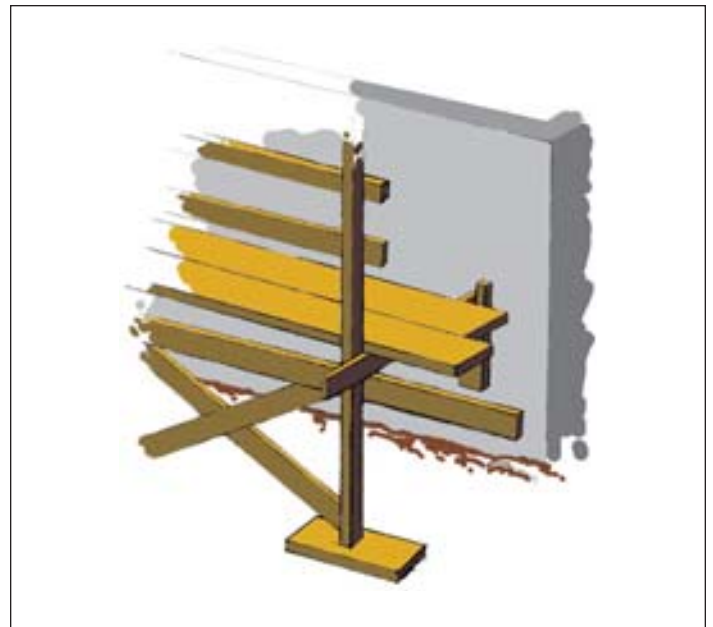

Guardrails are required when the work platform is 3 m (10 ft.) or more.

Roof jacks and toe-holds

Roof jacks must be of substantial construction and maintained in good condition.

Roof jacks must be provided with effective non-slip devices.

Exposed horizontal roof strapping may be used as toe-holds as long as it provides safe footing.

Crawl boards or ladders used for roof work must be securely fastened over the ridge of the roof or must be otherwise effectively anchored.

The use of eavestroughs for support is prohibited.

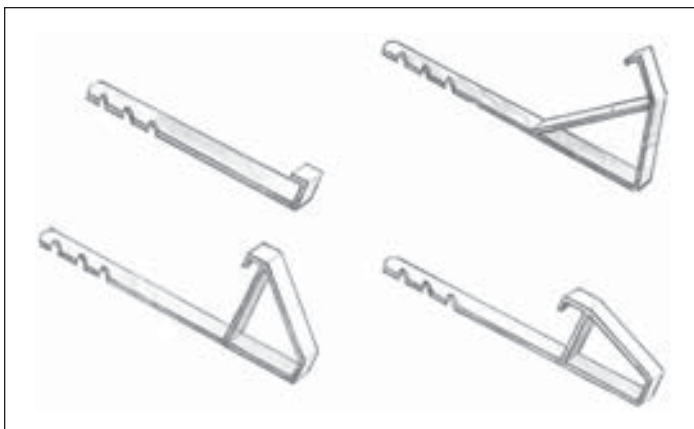
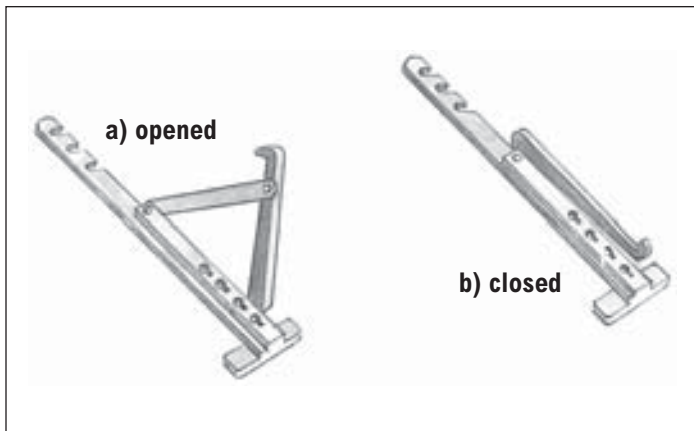

Flat roofs or roofs up to 4 in 12 slope

Fall protection systems must be used when there is a possibility of a fall 3 m (10 ft.) or more.

Selecting Fall Protection

When determining which fall protection system is most practicable, you must always follow the fall protection hierarchy as set out in section 11.2 of the Occupational Health and Safety Regulation.

1st Consideration – Are guardrails practical?

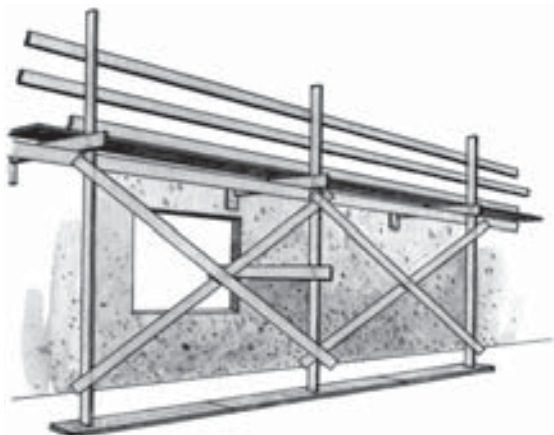

3rd Consideration – Can a fall arrest system be used?



2nd Consideration – Can another fall restraint system be used?



4th Consideration – If none of the above systems can be used, other written procedures acceptable to the WCB can be used.

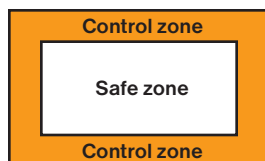

Roof over 4 in 12 slope but less than 8 in 12

Fall protection systems must be used when there is a possibility of a fall 3 m (10 ft.) or more.

Selecting Fall Protection

When determining which fall protection system is most practicable, you must always follow the fall protection hierarchy as set out in section 11.2 of the Occupational Health and Safety Regulation.

1st Consideration – Are guardrails practical?

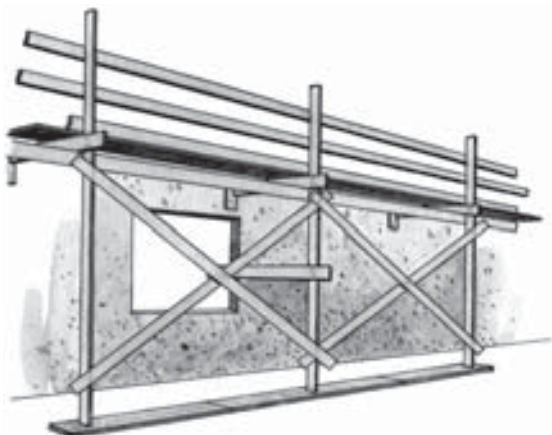

*3rd Consideration –
Can a fall arrest system be used?*



*2nd Consideration –
Can another fall
restraint system
be used?*

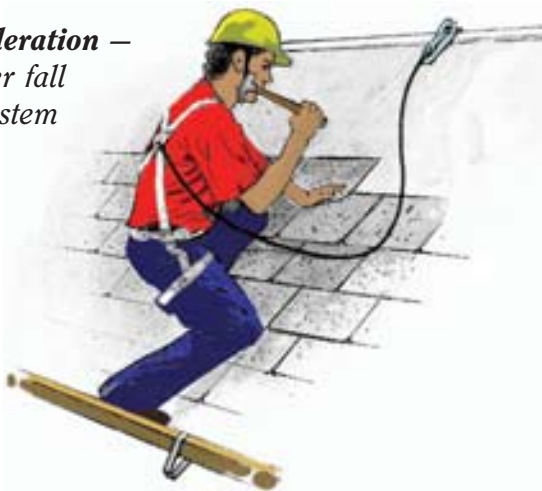

*4th Consideration – If none of the above systems
can be used, other written procedures acceptable to
the WCB can be used.*

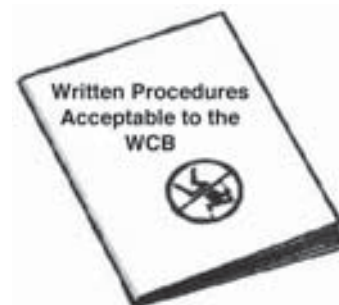

Roof 8 in 12 slope or more

Fall protection systems must be used when there is a possibility of a fall 3 m (10 ft.) or more.

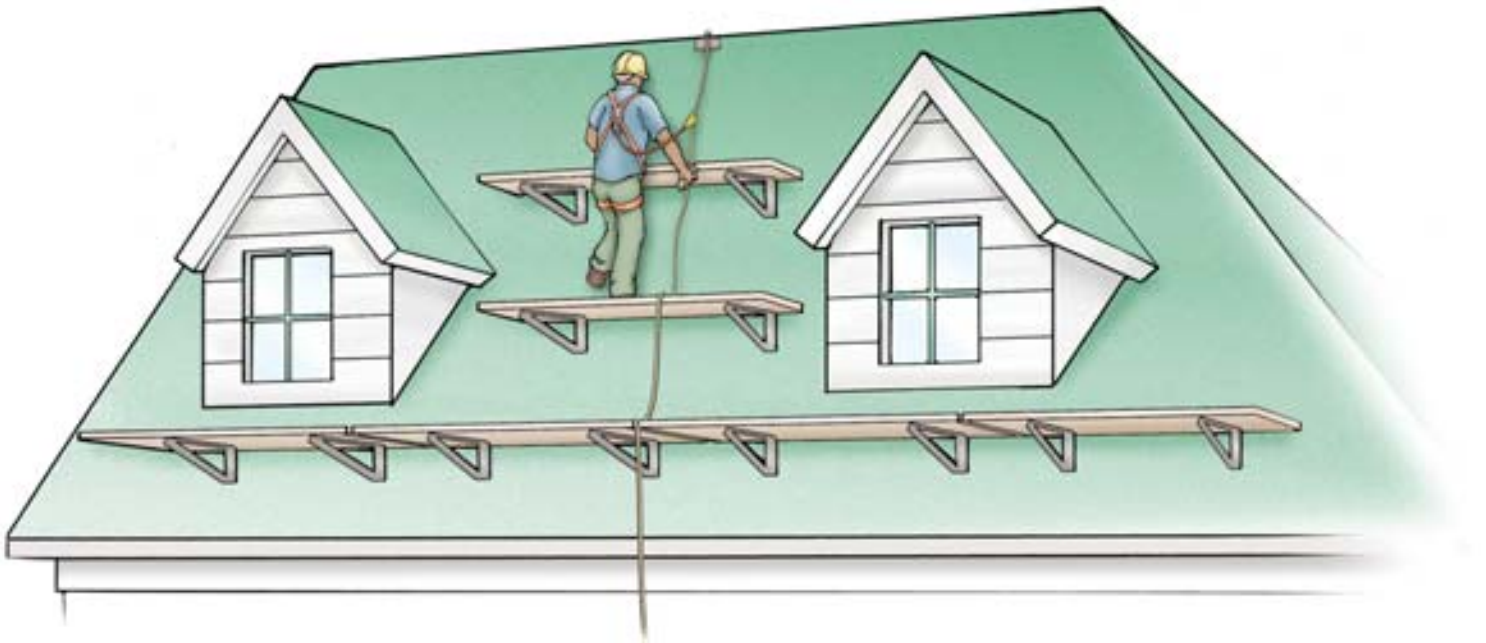

Both toe-hold and fall protection systems must be used when a roof has a slope of 8 to 12 (vertical to horizontal) or more.

Toe-holds must be at least 38 mm x 140 mm (2 in. x 6 in.)

