

Requirements for Secondary Voltage Revenue Metering (750 V and less)

To view the latest revision of this document go to:

<http://www.bchydro.com/ext/metering/>

January 15, 2008

BC Hydro 

Copyright and Reprint Provision

Copyright © 2008 by BC Hydro.

Reprint Provisions:

- (a) Copying all, or any part of, this document is permitted provided credit is given to BC Hydro and provided the copies of this document or parts thereof are not sold for profit; and
 - (b) This document may be stored in any type of electronic retrieval system provided BC Hydro is clearly indicated as the source and provided no profit accrues from such storage.
-

Table of Contents

1.	Overview	1
2.	Disclaimer	1
3.	General	2
3.1	Approval	2
3.2	Location	2
3.3	Access	3
3.4	Illumination	3
3.5	Existing Installations	3
3.6	Drawings	3
3.7	Definitions	4
3.8	Underground Main Service	4
3.9	Net Metering	4
3.10	Metering Type and Sequence	5
4.	Self-Contained Metering	7
4.1	General	7
4.2	Individual Meter Sockets	8
4.2.1	Meter Socket Cover Removal	8
4.2.2	Mounting Height	8
4.2.3	Enclosures for Permanent Meter Sockets	9
4.2.4	Recessed Mounting	9
4.2.5	Ground Connections	10
4.2.6	Meters Mounted on Poles	10
4.2.7	Gas Meters	10
4.3	Multiple Main Meter Sockets	10
4.4	Meter Centres	11
4.5	Grouped Sub Service Metering	12
4.6	Mobile Home Parks and Subdivisions	13
4.6.1	Mobile Home Parks	13
4.6.2	Mobile Home Subdivisions	13
4.6.3	Service Pedestals	14
4.7	Schematic Drawings	15
4.7.1	120/240 V, 1 Phase, 3 Wire, Main Service	16
4.7.2	120/240 V, 1 Phase, 3 Wire, Sub Services	17
4.7.3	120/208 V, Network, Main Service	18
4.7.4	120/208Y V, 3 Phase, 4 Wire, Main Service	19
4.7.5	120/208Y V, 3 Phase, 4 Wire, Sub Services	20
4.7.6	277/480Y V, 3 Phase, 4 Wire, Main Service	21
4.7.7	277/480Y V, 3 Phase, 4 Wire, Sub Services	22
4.7.8	347/600Y V, 3 Phase, 4 Wire, Main Service	23
4.7.9	347/600Y V, 3 Phase, 4 Wire, Sub Services	24
4.7.10	240 V, 3 Phase, 3 Wire Delta, Main Service	25
4.7.11	480 V, 3 Phase, 3 Wire Delta, Main Service	26
4.7.12	600 V, 3 Phase, 3 Wire Delta, Main Service	26

5.	Instrument Transformer Metering	27
5.1	General	27
5.1.1	1 Phase.....	27
5.1.1.1	Residential 1 Phase Services - 400 A or less.....	27
5.1.1.2	Residential 1 Phase Services - Over 400 A	28
5.1.1.3	Other 1 Phase Services.....	29
5.1.2	3 Phase.....	29
5.1.2.1	Residential 3 Phase Services	29
5.1.2.2	Other 3 Phase Services.....	30
5.2	Schematic Drawings	31
5.2.1	120/240 V, 1 Phase, 3 Wire Service – Instrument Transformer Enclosure or Compartment	31
5.2.2	120/240 V, 1 Phase, 3 Wire Service – 400 A Meter Socket Assembly, with an Integral CT	32
5.2.3	120/208Y V, 3 Phase, 4 Wire Service	33
5.2.4	277/480Y V or 347/600Y V, 3 Phase, 4 Wire Service	34
5.2.5	240 V, 3 Phase, 3 Wire Delta Service	35
5.2.6	480 V or 600 V, 3 Phase, 3 Wire Delta Service.....	36
5.3	Wall Mounted Instrument Transformer Enclosure	37
5.3.1	Responsibility.....	37
5.3.1.1	1 Phase.....	37
5.3.1.2	3 Phase.....	37
5.3.2	Equipment.....	38
5.3.2.1	120/240 V, 1 Phase, 3 Wire.....	40
5.3.2.2	3 Phase, 4 Wire Supply – 3 Phase 4 Wire Load	40
5.3.2.3	3 Phase, 4 Wire Supply – 3 Phase 3 Wire Load	40
5.3.2.4	3 Phase, 3 Wire Supply and Load	41
5.4	Switchgear Instrument Transformer Compartment.....	41
5.4.1	Responsibility.....	41
5.4.1.1	1 Phase.....	41
5.4.1.2	3 Phase.....	41
5.4.2	Equipment.....	42
5.4.2.1	120/240 V, 1 Phase, 3 Wire.....	44
5.4.2.2	3 Phase, 4 Wire Supply – 3 Phase 4 Wire Load	45
5.4.2.3	3 Phase, 4 Wire Supply – 3 Phase 3 Wire Load	45
5.4.2.4	3 Phase, 3 Wire Supply and Load	45
5.5	120/240 V, 1 Phase, 400 A Meter Socket Assembly, with an Integral CT....	46
5.5.1	Responsibility.....	46
5.5.2	Equipment.....	47
5.6	Pole Mounted Transrack.....	49
5.7	Instrument Transformers.....	49

5.8	Meter Cabinet	51
5.8.1	Indoor Installations.....	51
5.8.2	Outdoor Installations.....	52
5.8.3	Grounding	53
5.8.4	Optional Meter Compartment	54
5.9	Conduit.....	55
6.	Reference Drawings	56
6.1	Underground Main Service Meter Sockets	56
6.2	Sealing Ring.....	58
6.3	Individual Wall Mounted Meter Socket	59
6.4	Individual Pole Mounted Meter Socket	60
6.5	Individual Wall Mounted Meter Socket Near a Gas Meter.....	61
6.6	Multiple Main Meter Socket.....	62
6.7	Meter Centre	63
6.8	Grouped Sub Service Metering.....	64
6.9	Service Pedestal	65
6.10	120/240 V, 1 Phase, Wall Mounted Instrument Transformer Enclosure ...	66
6.11	3 Phase, Wall Mounted Instrument Transformer Enclosure	68
6.12	120/240 V, 1 Phase, Metering with a Single 3 Wire Bar Type CT	70
6.13	120/240 V, 1 Phase, Metering with Two 2 Wire Bar Type CTs	71
6.14	3 Phase, 4 Wire, Metering with Bar Type CTs.....	72
6.15	Typical Indoor Window CT.....	73
6.16	Typical Indoor/Outdoor Donut CT	74
6.17	120/240 V, 1 Phase, 400 A Meter Socket Assembly, with an Integral CT.	75
6.18	Outdoor Pole Mounted Transrack.....	77
6.19	Indoor Meter Cabinet	78
6.20	Indoor Wall Mounted Meter Cabinet Mounting Decal	79
6.21	Outdoor Wall Mounted Meter Cabinet	80
6.22	Outdoor Pole Mounted Meter Cabinet	81

1. Overview

This document contains BC Hydro's requirements for revenue metering installations operating at 750 V and less. These requirements also apply to revenue metering installations in the City of New Westminster.

Comments are written in italics.

2. Disclaimer

This document is not intended as a design specification or as an instruction manual for the Customer and this document shall not be used by the Customer for those purposes. Persons using information included in this document do so at no risk to BC Hydro, and they rely solely upon themselves to ensure that their use of all or any part of this document is appropriate in the particular circumstances.

The Customer, its employees or agents must recognize that they are, at all times, solely responsible for the plant design, construction and operation. Neither BC Hydro nor any of their employees or agents shall be nor become the agents of the Customer in any manner howsoever arising.

BC Hydro's review of the specifications and detailed plans shall not be construed as confirming or endorsing the design or as warranting the safety, durability or reliability of the Customer's facilities. BC Hydro, by reason of such review or lack of review, shall be responsible for neither the strength, adequacy of design or capacity of equipment built pursuant to such specifications, nor shall BC Hydro, or any of their employees or agents, be responsible for any injury to the public or workers resulting from the failure of the Customer facilities.

In general, the advice by BC Hydro, any of its employees or agents, that the Customer's plant design or equipment meets certain limited requirements of BC Hydro does not mean, expressly or by implication, that all or any of the requirements of the law or other good engineering practices have been met by the Customer in its plant, and such judgement shall not be construed by the Customer or others as an endorsement of the design or as a warranty, by BC Hydro, or any of its employees.

The information contained in this document is subject to change and may be revised at any time. BC Hydro should be consulted in case of doubt on the current applicability of any item.

3. General

3.1 Approval

- (a) The proposed metering equipment locations and voltage shall be approved by BC Hydro prior to installation. If the design is subsequently changed, re-approval is required prior to energization.
- (b) The metering equipment shall be certified and installed in accordance with the latest edition of the Canadian Electrical Code. If special permission for a deviation from the Canadian Electrical Code, that impacts metering, is requested from the provincial or municipal inspection authority, special written approval shall first be obtained from BC Hydro.

3.2 Location

- (a) Metering equipment:
- Shall be installed in a clean readily accessible location free from severe or continual vibration; and
 - Shall not be installed in locations which may be hazardous to persons installing, testing, reading or maintaining the equipment; and
 - Shall be protected from damage due to vandalism, vehicles etc; and
 - Shall not be installed in garages or carports; and
 - Shall not be installed in a location which requires ladder or manhole access.
- (b) In accordance with section 2 of the Canadian Electrical Code, a minimum working space of 1 m shall be provided and maintained about metering equipment.
- (c) If an existing metering location no longer meets the above criteria, the Customer shall relocate the metering equipment to a location that meets the above criteria.
- (d) Detached single family residential metering equipment shall not be located indoors.

See section 5.1.1.2 for a possible exception for 1 phase services over 400 A and section 5.1.2.1 for a possible exception for 3 phase services over 200 A.

3.3 Access

- (a) BC Hydro shall have reasonable access to the metering equipment to permit its reading, testing and maintenance.
- (b) Where it is proposed to locate metering equipment indoors, or within other secure areas, the accessibility arrangements, systems, equipment etc. shall be agreed upon by BC Hydro prior to approval of the proposed location.

Equipment and systems may include keys, lock boxes, key fobs, smart cards etc.

- (c) Rooms on the first floor or basement/parkade level containing metering equipment shall be accessible by a door leading directly to the exterior or the parkade level of the building.

3.4 Illumination

- (a) When installed indoors, the metering equipment shall be installed in a location with a minimum illumination of:
 - 100 to 200 lux horizontal at 750 mm above grade; and
 - 100 lux vertical at the front face of the meter.
- (b) Lighting, in rooms containing metering equipment, shall be controlled by a wall switch at the room entrance.

Pull chains on lights are not acceptable.

3.5 Existing Installations

- (a) Alterations shall not be made to existing metering installations without the prior written approval of BC Hydro.
- (b) Procedures for the temporary disconnection of self-contained meters, by electrical contractors only, to permit wiring alterations are available from BC Hydro. Approval shall be obtained in advance on an individual job basis.

3.6 Drawings

When drawings, specifications and site plans are submitted to BC Hydro, details of the proposed metering equipment and locations shall be included.

3.7 Definitions

Except where noted below, definitions shall be in accordance with section 2 of the Canadian Electrical Code.

Instrument Transformer means a high accuracy **Voltage Transformer (VT)** or **Current Transformer (CT)** that transforms the circuit voltage and current to lower levels for connection to an instrument transformer type meter.

Instrument Transformer Metering means a metering installation where the meter is connected to the metered circuit conductors via instrument transformers.

Meter Cabinet means the BC Hydro supplied cabinet for mounting a 3 phase instrument transformer meter.

Meter Socket means the Customer supplied device for mounting a self-contained meter or a 1 phase instrument transformer meter. The meter socket is referred to as the meter mounting device in the Canadian Electrical Code.

Network Service or Load means a service or load consisting of two phase conductors plus a neutral conductor supplied from a 3 phase, 4 wire power system.

Self-Contained Metering means a metering installation where the meter is installed directly in series with the circuit conductors.

3.8 Underground Main Service

Underground main service meter sockets shall be in accordance with section 6.1.

Contact BC Hydro and refer to the ES53 Series Underground Electrical standards and the ES54 Underground Civil standards for underground main service conduit, wireway and pull box requirements.

Overhead service meter socket dimensions are not specified since BC Hydro does not install or terminate the service conductors at the meter socket.

3.9 Net Metering

For net metering applications, refer to the BC Hydro requirements at <http://www.bchydro.com/info/ipp/ipp8842.html> and to the Canadian Electrical Code section 84.

3.10 Metering Type and Sequence

(a) **Self-contained metering**, in accordance with section 4 and the following table, is required for all loads of **200 A or less**. Except that, instrument transformer metering is required for 600 V, 3 Phase, 3 Wire, Delta services of 200 A or less.

(b) **Instrument transformer metering**, in accordance with section 5 and the following table, is required for:

- All loads **over 200 A**; and
- 600 V, 3 Phase, 3 Wire, Delta services.

Metering Type and Location Summary Table

Current	Metering Type	Voltage	Service	Fault Current	Metering Location <i>See Note 1</i>	Neutral <i>See Note 2</i>
200 A or less	Self Contained	300 V or less	Main	10,000 A or less	Line (Hot)	Bonded
				Over 10,000 A	Load (Cold)	Isolated
			Sub	Any Level	Load (Cold)	Isolated
		277/480Y V 3 Phase 4 Wire	Main or Sub	Any Level	Load (Cold)	Isolated
		480 V 3 Phase 3 Wire Delta	Main or Sub	Any Level	Load (Cold)	NA
		347/600Y V 3 Phase 4 Wire	Main or Sub	Any Level	Load (Cold)	Isolated
	Instrument Transformer	600 V 3 Phase 3 Wire Delta	Main or Sub	Any Level	Load (Cold)	NA
Over 200 A	Instrument Transformer	See Schematic Drawings				

-
1. The metering location is relative to the main service box or sub service disconnect device. Line side metering is referred to as “hot” metering. Load side metering is referred to as “cold” metering.
 2. In accordance with section 10-624 of the Canadian Electrical Code, where a meter socket is located on the line side of the main service box, the neutral shall be bonded to the meter socket. In accordance with sections 10-204 and 10-624 of the Canadian Electrical Code, where a self-contained meter socket is located on the load side of the main service box, the neutral shall be isolated from the meter socket.
 3. Where a 3 phase, 4 wire supply, serves a 3 phase, 3 wire load, the neutral shall be part of the metering circuit and shall be extended to the point-of-metering.

4. Self-Contained Metering

Self-contained metering, is required for all loads of 200 A or less. Except that, instrument transformer metering is required for 600 V, 3 Phase, 3 Wire, Delta services of 200 A or less.

4.1 General

(a) The Customer shall supply the meter socket and sealing ring. They shall be certified in accordance with CSA Standard C22.2 No. 115, *Meter Mounting Devices* and they shall be approved by BC Hydro.

(b) The sealing ring shall be a screw type in accordance with section 6.2.

Ringless meter sockets are not permitted.

(c) The neutral terminal on 5 jaw meter sockets shall be in the 9 o'clock position.

Prior to 2005 the neutral terminal on some 5 jaw meter sockets was required to be in the 6 o'clock position. When adding a new 5 jaw sub service meter socket to an existing installation, the new meter socket neutral terminal shall be in the 9 o'clock position, even if the existing neutral terminals are in the 6 o'clock position.

(d) The meter tilt shall not exceed 3° from vertical.

(e) Metered and unmetered conductors shall not be installed in the same raceway, pull box or distribution gutter box.

(f) Where a 3 phase, 4 wire supply, serves a 3 phase, 3 wire load, a 7 jaw, 3 phase, 4 wire meter socket shall be installed and the neutral shall be extended to the meter socket.

(g) Other devices, including surge arrestors, generator transfer switches, etc. shall not be installed within meter sockets or between the meter socket and the BC Hydro meter.

(h) Prior to the installation of the meter, the Customer shall provide a durable temporary weather resistant cover over the meter socket opening.

(i) Underground service meter sockets shall be in accordance with section 6.1.

Overhead service meter socket dimensions are not specified since BC Hydro does not install the conductors.

4.2 Individual Meter Sockets

4.2.1 Meter Socket Cover Removal

Removal of the meter socket cover shall not be possible unless the following sequence is followed:

- Removal of the sealing ring;
- Removal of the meter;
- Operation of the meter socket cover latch;
- Removal of the meter socket cover.

Configurations that rely on seals, in addition to the BC Hydro sealing ring seal, or padlocks to prevent removal of the meter socket cover are not permitted.

4.2.2 Mounting Height

- (a) The meter socket centre line shall be 1500 mm to 1800 mm above finished grade in accordance with section 6.3, 6.4 and 6.5. Except that, where a meter socket is mounted on a service pedestal, or other similar custom equipment, the meter socket centre line shall be 915 mm to 1800 mm above finished grade and the meter socket shall not be subject to vehicle damage.
- (b) If the Customer intends to build up the grade after the meter has been installed, a platform or ramp shall be provided during the interim period. The platform shall not be less than 900 mm by 900 mm.

4.2.3 Enclosures for Permanent Meter Sockets

(a) Permanent meter sockets may be installed within enclosures provided:

- Special written approval is obtained from BC Hydro; and
- The enclosure has a hinged door; and
- The enclosure and door do not interfere with the installation, reading or removal of the meter; and
- The enclosure and door do not interfere with the installation or removal of the meter socket cover; and
- The following clearances are provided between the inside of the closed enclosure door and the meter socket cover:
 - 255 mm for 1 phase and network meters; and
 - 380 mm for 3 phase meters.

(b) If it is proposed to lock the enclosure, the details of the locking scheme shall also be approved by BC Hydro.

Approval for the installation of permanent meter sockets within enclosures is typically only given where the meter may be subject to vandalism.

Temporary construction power meter sockets may installed within enclosures.

4.2.4 Recessed Mounting

Meter sockets may be recessed within exterior walls provided:

- The associated service conductors are permitted to be installed within the exterior wall;
- The recess depth is less than the depth of the meter socket, i.e. the meter socket cover shall project beyond the finished exterior wall surface; and
- Recessing does not interfere with the installation, reading or removal of the meter; and
- Recessing does not interfere with the installation or removal of the meter socket cover.

The overhead service mast and conductors are consumer service conductors. Section 6-208 of the Canadian Electrical Code restricts the installation of consumer service conductors within an exterior wall.

In accordance with section 3.2, for detached single family residential services, the meter shall be on the outside of the exterior wall.

4.2.5 Ground Connections

Where permitted by the Canadian Electrical Code, ground connections for other systems, such as telephone or cable TV, shall:

- Not terminate within the meter socket; and
- Not interfere with the installation, reading or removal of the meter; and
- Not interfere with the installation or removal of the meter socket cover.

4.2.6 Meters Mounted on Poles

Meter sockets shall be located on the side of the pole that is not subject to vehicle damage. If this is not practicable, protection posts shall be installed 600 mm in front of the meter socket in accordance with section 6.4.

4.2.7 Gas Meters

Meter sockets shall not be installed within 1000 mm of gas meters, regulators or relief devices. See section 6.5.

4.3 Multiple Main Meter Sockets

When, in accordance with section 6-104 of the Canadian Electrical Code, a maximum of four meter sockets, connected to one supply service, are installed on the exterior of a building, the multiple main meter sockets:

(a) Shall be part of a certified manufactured assembly; and

Site fabricated assemblies are not permitted.

(b) Shall be installed in accordance with section 6.6; and

(c) Shall meet the requirements of individual meter sockets in section 4.2; and

(d) If they have a separate supply service compartment, removal of the supply service compartment cover, shall require operation of a latch that can only be accessed by the removal of the adjacent meter.

Assemblies that require the installation of a padlock or non-meter ring seal to secure the supply service compartment cover are not permitted.

(e) Prior to the installation of the meters by BC Hydro:

- Each Customer suite address or suite number shall be permanently and legibly marked on each meter socket; and
- All suite doors, complete with their permanent address or suite numbers, shall be installed.

Multiple main meter sockets are “hot style” and are located on the line side of their respective main service boxes. “Hot style” metering may only be used where the fault current is less than 10,000 A.

4.4 Meter Centres

(a) Meter centres shall be installed in accordance with section 6.7; and

(b) Meter centres shall be certified in accordance with CSA Standard C22.2 No. 229 *Switching and Metering Centres* and shall be approved by BC Hydro; and

(c) Meter centres shall be cold style with the meter socket located on the load side of the associated circuit breaker; and

(d) The circuit breaker shall have provision for locking in the open position; and

(e) The centre-to-centre dimension of adjacent meter sockets shall not be less than 220 mm; and

(f) Prior the installation of the meters by BC Hydro:

- Each Customer suite address or suite number shall be permanently and legibly marked on each meter socket; and
- All suite doors, complete with their permanent address or suite numbers, shall be installed; and

(g) Meter centres may be located behind a hallway door provided the door frame does not restrict the required 1 m clearance. The following clearances shall be provided between the closed door and each meter socket cover:

- 255 mm for 1 phase and network meters; and
- 380 mm for 3 phase meters.

4.5 Grouped Sub Service Metering

- (a) Grouped, field constructed sub service meter assemblies shall be in accordance with section 6.8; and
- (b) The individual meter sockets shall be in accordance with section 4.2. Except that the meter sockets may be from 700 mm to 1800 mm above finished grade; and
- (c) The grouped sub service metering shall be cold style with each meter socket located on the load side of a sub service disconnect device; and

The main service box is not an acceptable means for isolating a sub service meter socket. Each sub service meter socket therefore requires its own disconnect device.

Additions to existing non conforming installations shall be in accordance with this requirement.

- (d) The sub service disconnect device shall have provision for locking in the open position; and
- (e) In accordance with section 4.1, metered and unmetered conductors shall not be installed in the same raceway or distribution gutter box; and
- (f) The distribution gutter box shall have provision for the installation of BC Hydro seals; and
- (g) The centre-to-centre dimension of adjacent meter sockets shall not be less than 255 mm; and
- (h) Each meter socket shall be:
 - Adjacent to, and as close as practicable to, the controlling sub service disconnect device; and
 - In the same room as the controlling sub service disconnect device; and

It shall be immediately obvious from the conduit configuration which sub service disconnect device is controlling each meter socket. It is unacceptable to supply the meter sockets from circuit breakers located in a panelboard.

(i) Each sub service disconnect device shall be:

- Adjacent to, and as close as practicable to, the distribution gutter box; and
- In the same room as the distribution gutter box; and

(j) Prior the installation of the meters by BC Hydro:

- Each Customer suite address or suite number shall be permanently and legibly marked on each meter socket and sub service disconnect device; and
- All suite doors, complete with their permanent address or suite numbers, shall be installed; and

(k) Where a 3 phase, 4 wire supply, serves a 3 phase, 3 wire load, a 7 jaw, 3 phase, 4 wire meter socket shall be installed and the neutral shall be extended from the distribution gutter box to the meter socket. The neutral conductor:

- Shall not be smaller than the minimum conductor size rating of the meter socket neutral terminal; and
- Shall not be smaller than #6 AWG.

4.6 Mobile Home Parks and Subdivisions

4.6.1 Mobile Home Parks

At mobile home parks, meters may be located in either:

- Meter Centres; or
- Service pedestals.

4.6.2 Mobile Home Subdivisions

At mobile home subdivisions, where there are individual property lots; meters may be located in either:

- Meter Centres; or
- Service pedestals; or
- Individual Meter Sockets.

4.6.3 Service Pedestals

The service pedestal:

- (a) Meter socket shall be in accordance with section 4.2 and section 6.9; and
- (b) Shall have a continuous barrier between the unmetered supply conductors and the metered load conductors; and;
- (c) Shall permit access to the unmetered supply conductors only after performing the following removal sequence:
 - Meter sealing ring; then
 - Meter; then
 - Meter socket cover; then
 - Unmetered supply conductor cover.

Pedestals that require the installation of a padlock or non-meter ring seal to secure the unmetered conductor cover are not permitted.

- (d) The service pedestal unmetered supply conductors shall be installed in a continuous conduit between the BC Hydro point of supply and the service pedestals. Intermediate underground enclosures, or other potential points of access, are not permitted.

4.7 Schematic Drawings

Self-contained meter sockets shall be in accordance with the schematic drawings in this section.

*In accordance with section 3.10, “hot” metering, with the meter socket on the line side of the service box, is only required for the following **main services** where the fault current is 10,000 A or less:*

- 120/240 V, 1 phase, 3 wire; or
- 120/208 V, Network (very limited application); or
- 120/208Y V, 3 phase, 4 wire; or
- 240 V, 3 phase, 3 wire delta.

*All other **main services** require “cold” metering, with the meter socket on the load side of the service box.*

*All **sub services** require “cold” metering, with the meter socket on the load side of the sub service disconnect device.*

For “hot” metering, the neutral shall be bonded to the meter socket.

For “cold” metering, the neutral shall be isolated from the meter socket.

In accordance with section 4.1, where a 3 phase, 4 wire supply, serves a 3 phase, 3 wire load, a 7 jaw, 3 phase, 4 wire meter socket shall be installed and the neutral shall be extended to the meter socket.

4.7.1 120/240 V, 1 Phase, 3 Wire, Main Service

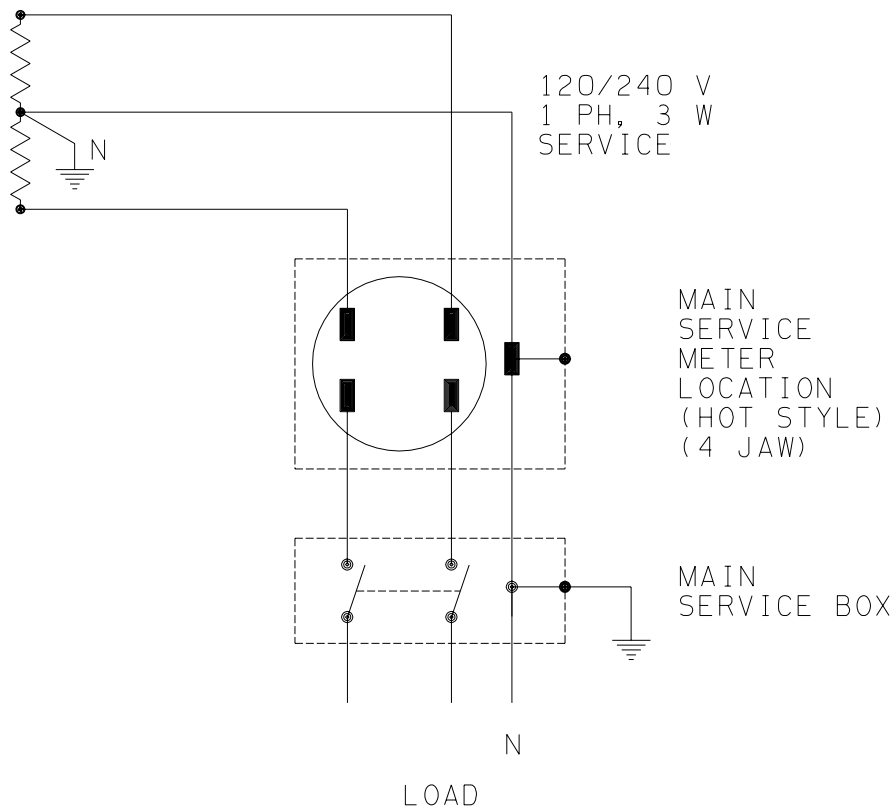

Notes:

1. This is a typical residential service. In accordance with section [3.2](#), for detached single family residential services, the meter socket shall not be located indoors.
2. 120 V, 1 phase, 2 wire services are no longer provided.
3. The above hot style configuration is applicable if the service fault current is 10,000 A or less. **If the service fault current is greater than 10,000 A:**
 - The meter shall be on the load side of the main service box (cold style); and
 - The neutral shall not be bonded at the meter.

4.7.2 120/240 V, 1 Phase, 3 Wire, Sub Services

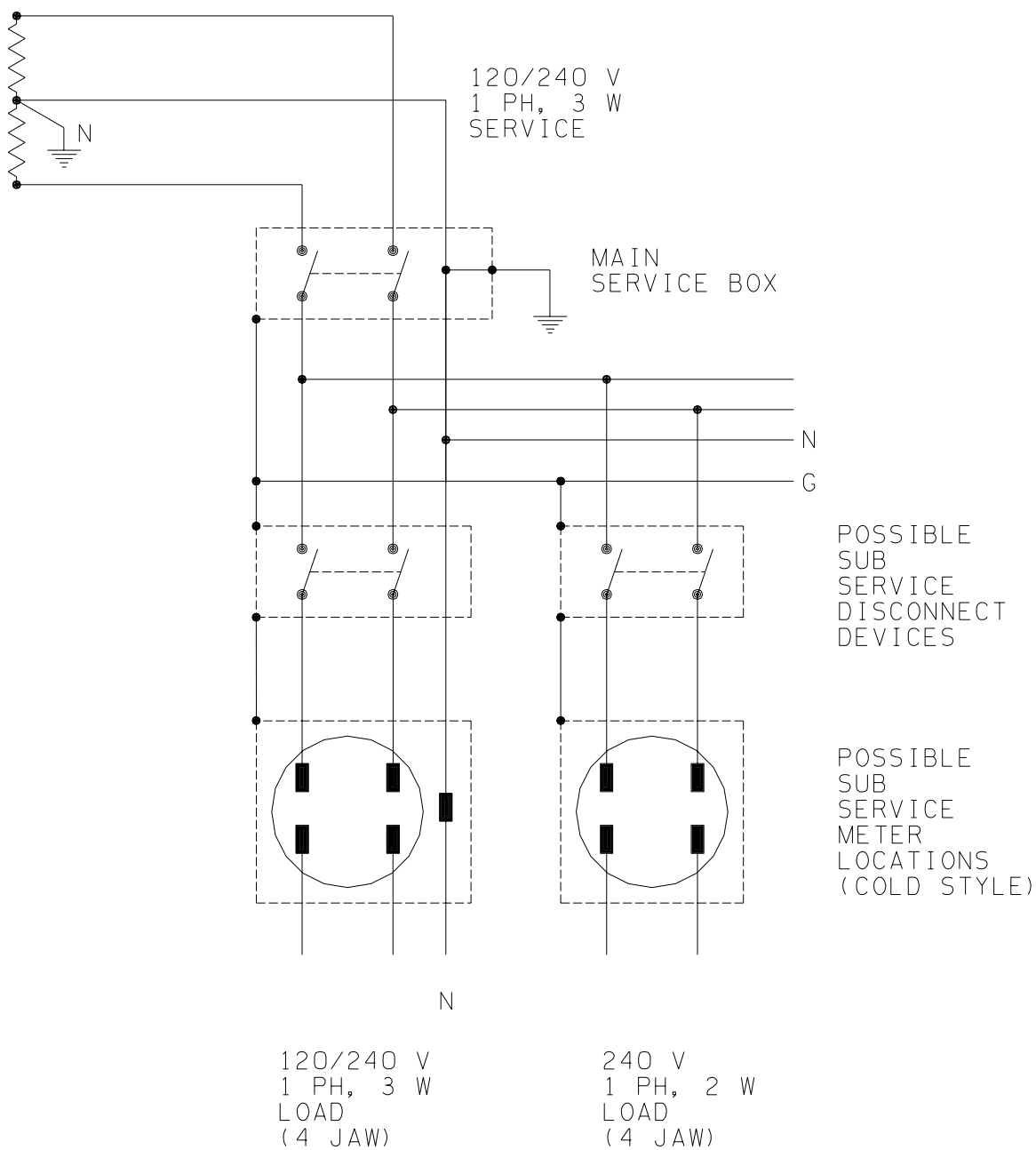

4.7.3 120/208 V, Network, Main Service

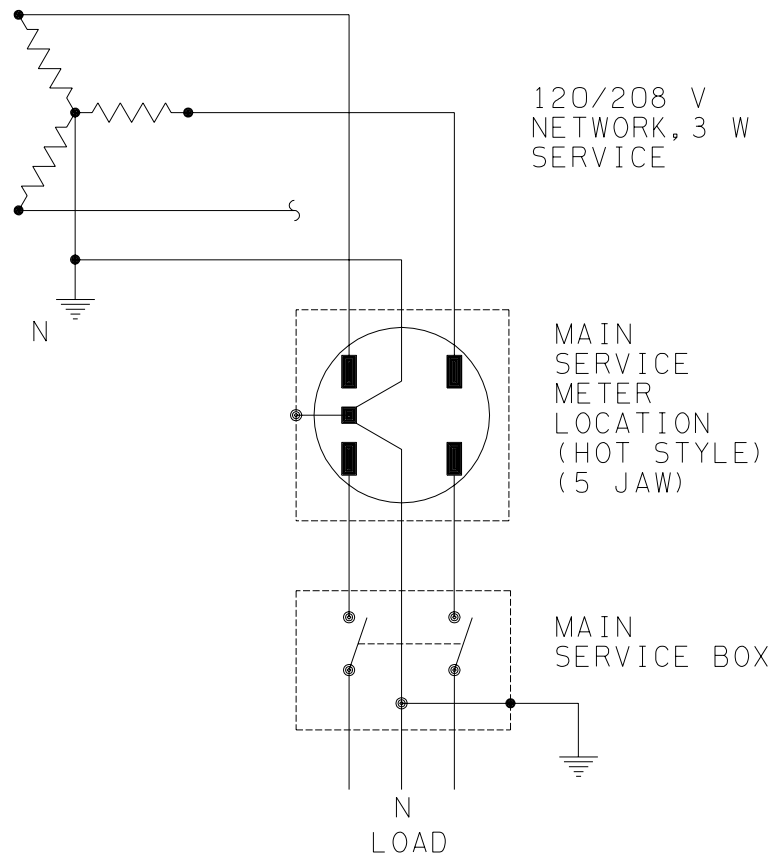

Notes:

1. A 120/208 V, network service consists of two phase conductors plus a neutral conductor supplied from a 120/208Y V, 3 phase, 4 wire power system.
2. 120/208 V network main services are restricted to downtown Victoria and a very limited number of other locations.
3. The above hot style configuration is applicable if the service fault current is 10,000 A or less. **If the service fault current is greater than 10,000 A:**
 - The meter shall be on the load side of the main service box (cold style); and
 - The neutral shall not be bonded at the meter.

4.7.4 120/208Y V, 3 Phase, 4 Wire, Main Service

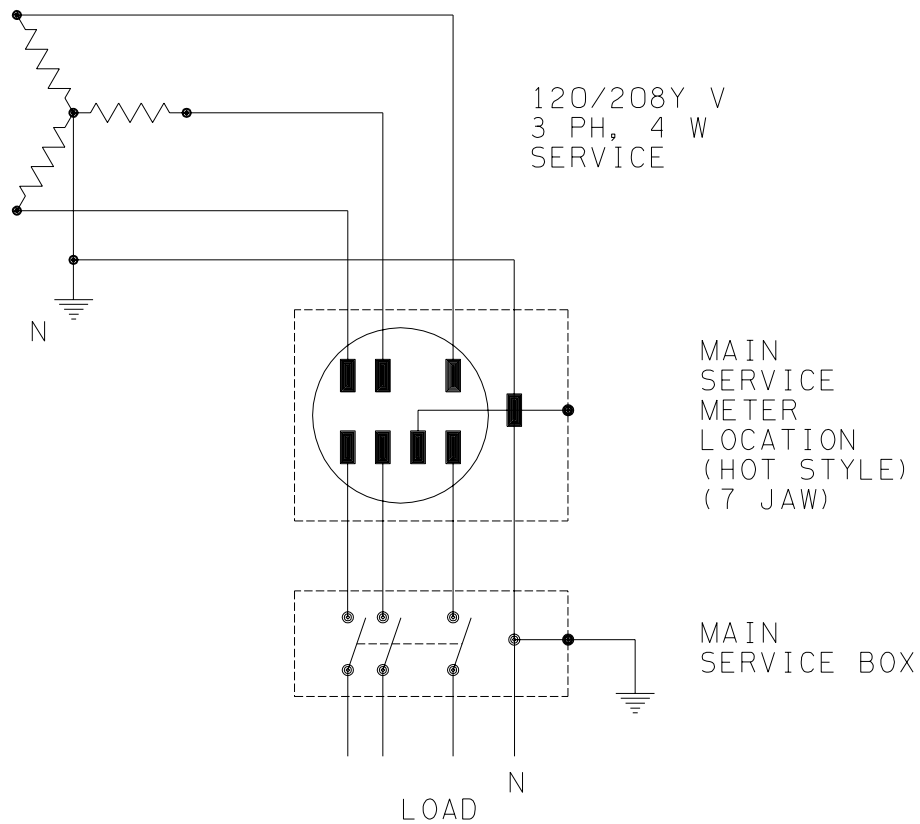

Notes:

1. The above hot style configuration is applicable if the service fault current is 10,000 A or less. **If the service fault current is greater than 10,000 A:**
 - The meter shall be on the load side of the main service box (cold style); and
 - The neutral shall not be bonded at the meter.

4.7.5 120/208Y V, 3 Phase, 4 Wire, Sub Services

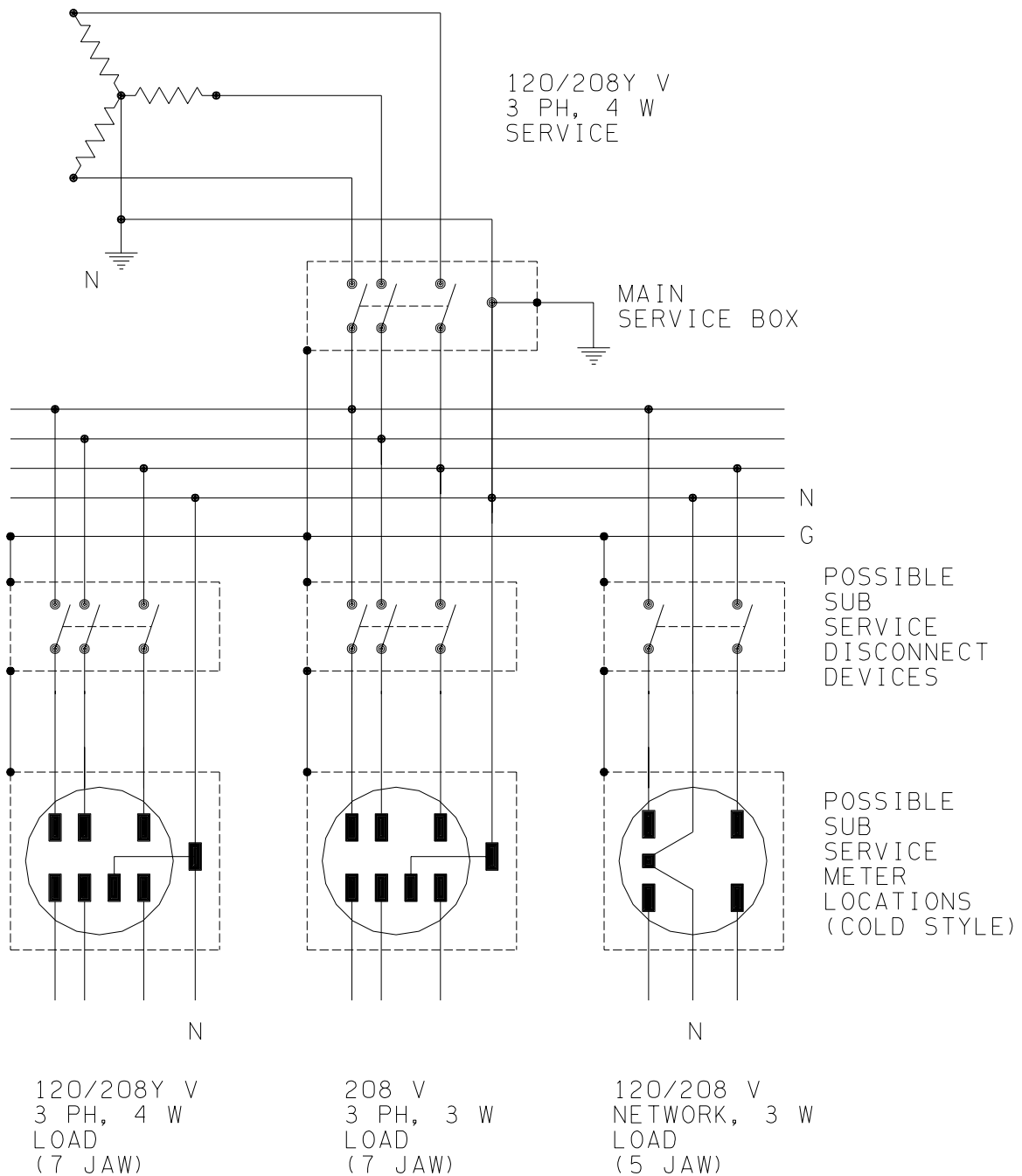

4.7.6 277/480Y V, 3 Phase, 4 Wire, Main Service

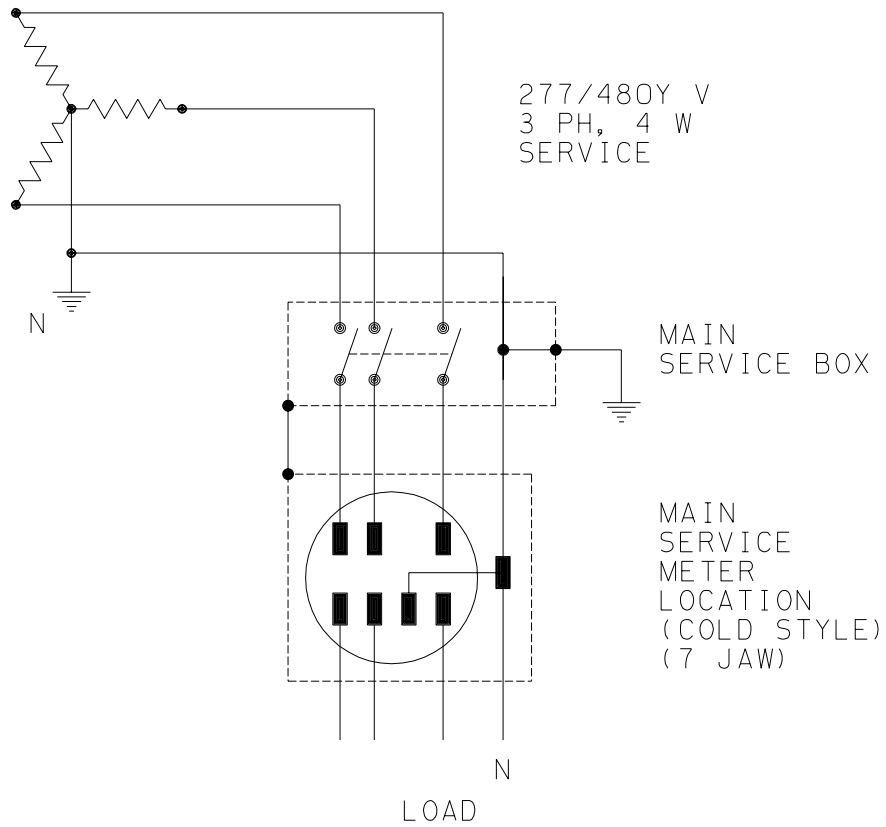

Notes:

1. This is not a standard BC Hydro service voltage, However, if the Customer provides the power transformers, BC Hydro will provide the meter.

4.7.7 277/480Y V, 3 Phase, 4 Wire, Sub Services

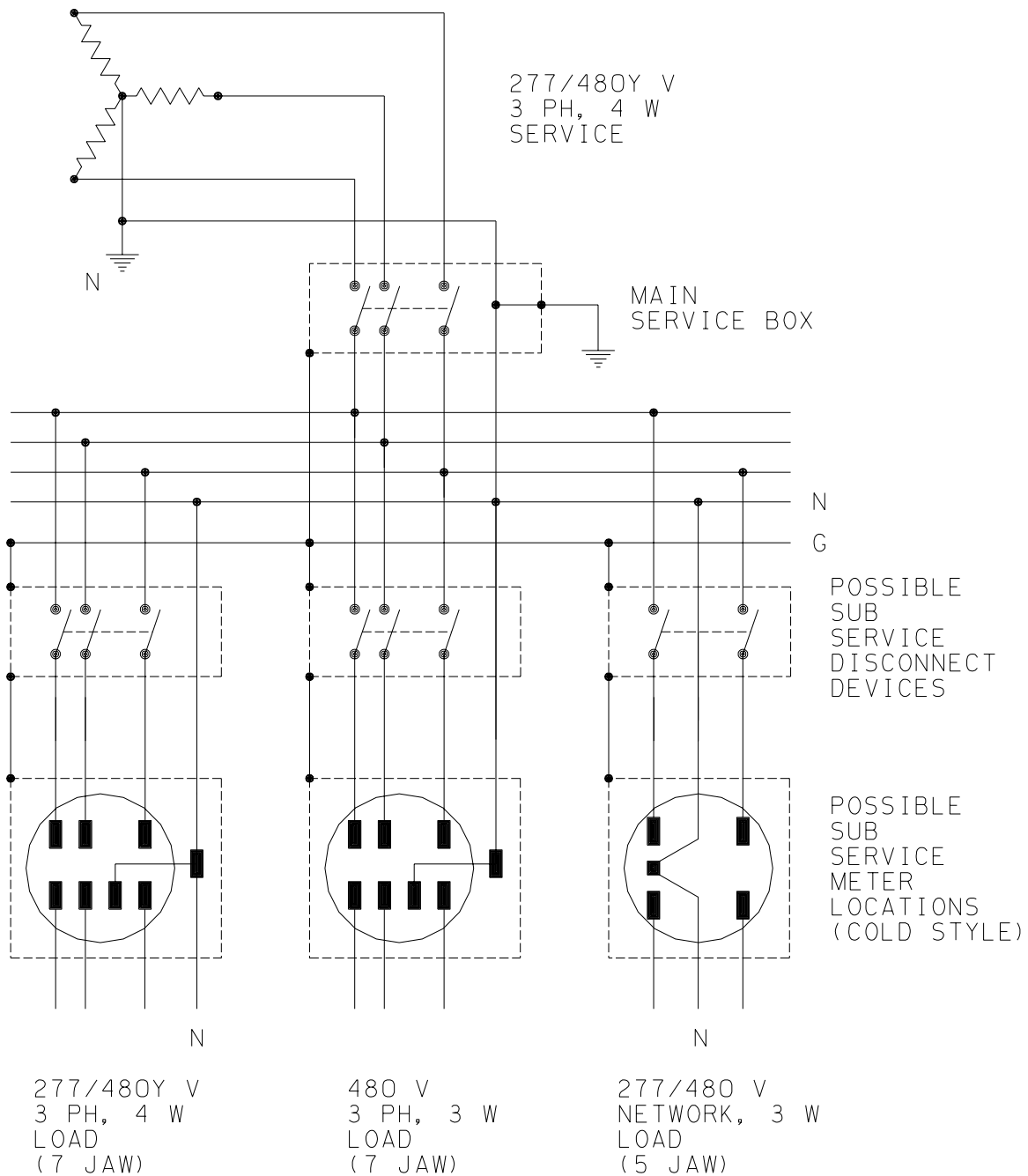

Notes:

1. This is not a standard BC Hydro service voltage, However, if the Customer provides the power transformers, BC Hydro will provide the meter.

4.7.8 347/600Y V, 3 Phase, 4 Wire, Main Service

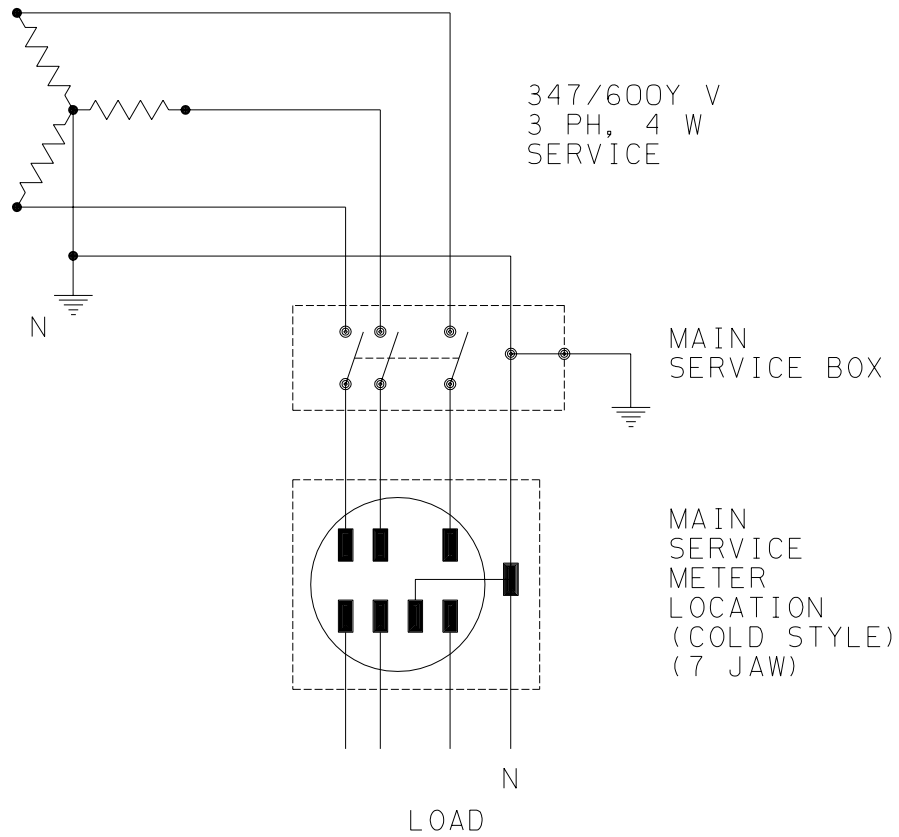

4.7.9 347/600Y V, 3 Phase, 4 Wire, Sub Services

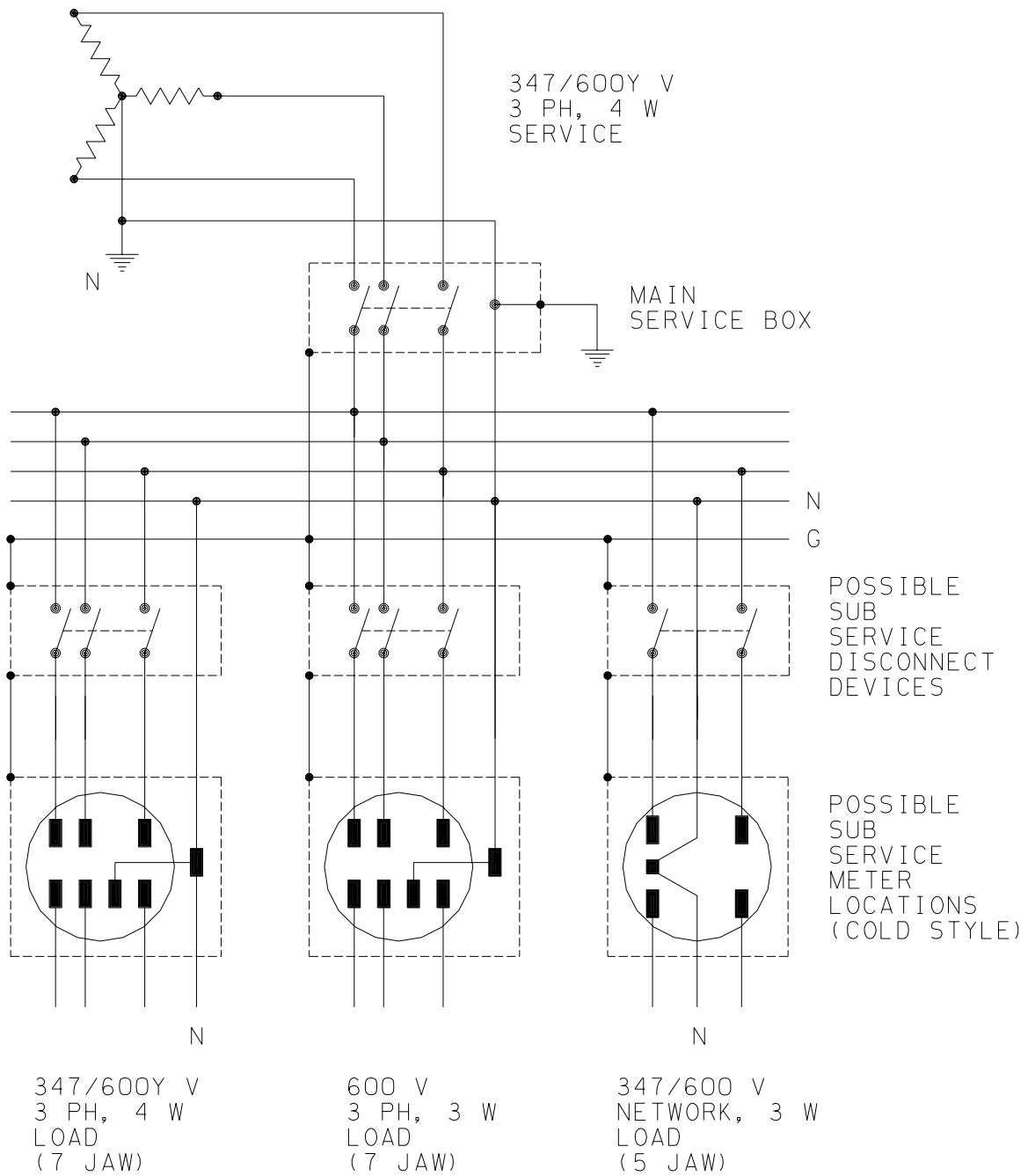

4.7.10 240 V, 3 Phase, 3 Wire Delta, Main Service

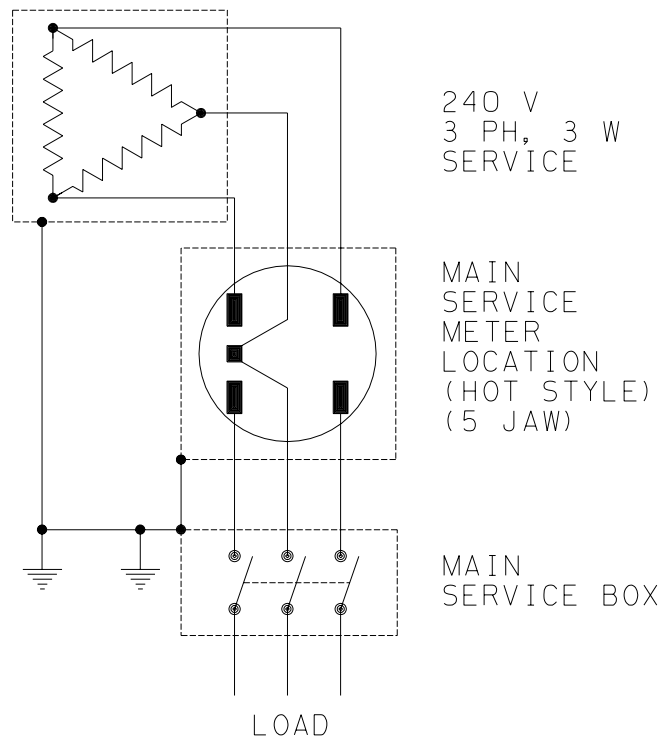

Notes:

1. This is not a standard BC Hydro service voltage. However, if the Customer provides the power transformers, BC Hydro will provide the meter.
2. Since there is no neutral (grounded service conductor), alternative methods shall be used to insure that the meter socket is bonded to ground. See section 10-604, 10-606 and 10-624 of the Canadian Electrical Code.
3. The above hot style configuration is applicable if the service fault current is 10,000 A or less. **If the service fault current is greater than 10,000 A**, the meter shall be on the load side of the main service box (cold style).

4.7.11 480 V, 3 Phase, 3 Wire Delta, Main Service

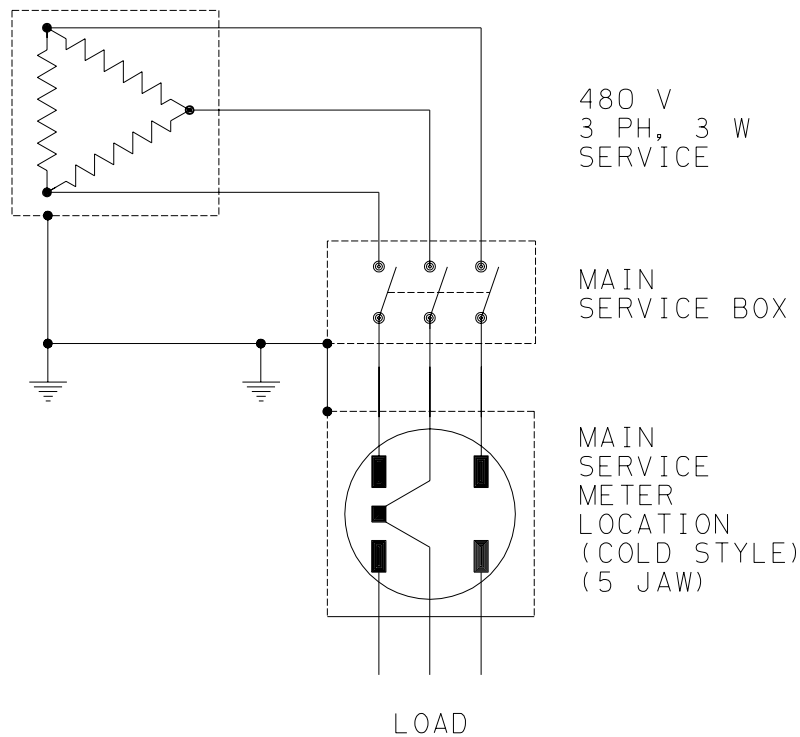

Notes:

1. 480 V, 3 Phase, 3 Wire Delta is not a standard BC Hydro service voltage. However, if the Customer provides the power transformers, BC Hydro will provide a 480 V, 3 Phase, 3 Wire self-contained meter.

4.7.12 600 V, 3 Phase, 3 Wire Delta, Main Service

600 V, 3 Phase, 3 Wire Delta is not a standard BC Hydro service voltage and BC Hydro does not provide self-contained 600 V, 3 Phase, 3 Wire Delta meters for new services. However, if the Customer provides the power transformers, BC Hydro will supply 600 V, 3 Phase, 3 Wire Delta instrument transformer metering. See section [5.2.6](#).

5. Instrument Transformer Metering

Instrument transformer metering is required for:

- All loads over 200 A; and
- 600 V, 3 Phase, 3 Wire, Delta services 200 A or less.

5.1 General

- (a) Metered and unmetered conductors shall not be installed in the same raceway, pull box or distribution gutter box.
- (b) Customer devices shall not be connected to BC Hydro VT and CT secondary winding circuits.

5.1.1 1 Phase

5.1.1.1 Residential 1 Phase Services - 400 A or less

Detached single family residential 1 phase services, 400 A and less, shall be metered with an outdoor **120/240 V, 1 Phase, 400 A meter socket assembly, with an integral CT**, in accordance with section 5.5.

The preferred location is near the property line or on the exterior of the house.

5.1.1.2 Residential 1 Phase Services - Over 400 A

(a) Detached single family residential 1 phase services, over 400 A, shall be metered with either:

- An outdoor wall mounted **instrument transformer enclosure** and an outdoor **meter socket** in accordance with section 5.3; or
- An outdoor switchgear **instrument transformer compartment** and an outdoor **meter socket** in accordance with section 5.4.

The preferred location is near the property line or on the exterior of the house. In accordance with section 5.9, the conduit between the instrument transformer enclosure/compartment and the meter socket shall be as short as practicable and shall not be installed through a wall or underground.

(b) Notwithstanding the above requirement, where special written approval is obtained from BC Hydro, the instrument transformer enclosure/compartment and meter socket may be located indoors provided:

- They are located in a room with a door leading directly to the exterior of the building;
- The accessibility arrangements for the exterior door are agreed upon by BC Hydro prior to approval.

The meter socket access arrangements would typically require a lock box similar to a commercial building meter room.

In accordance with section 5.9, where the instrument transformer enclosure/compartment is located indoors, the meter socket shall be located indoors in the same room as the instrument transformer enclosure/compartment.

5.1.1.3 Other 1 Phase Services

1 phase, services, other than detached single family residential, shall be metered with either:

- A wall mounted **instrument transformer enclosure** and **meter socket** in accordance with section 5.3; or
- A switchgear **instrument transformer compartment** and **meter socket** in accordance with section 5.4; or
- A **120/240 V, 1 Phase, 400 A meter socket assembly, with an integral CT** in accordance with section 5.5; or
- A pole mounted **transrack** and **meter cabinet** in accordance with section 5.6.

In accordance with section 5.9, where the instrument transformer enclosure/compartment is located indoors, the meter socket shall be located indoors in the same room as the instrument transformer enclosure/compartment.

5.1.2 3 Phase

5.1.2.1 Residential 3 Phase Services

(a) Detached single family residential 3 phase services shall be metered with either:

- An outdoor wall mounted **instrument transformer enclosure** and an outdoor **meter cabinet** in accordance with section 5.3; or
- An outdoor switchgear **instrument transformer compartment** and an outdoor **meter cabinet** in accordance with section 5.4.

The preferred location is near the property line or on the exterior of the house. In accordance with section 5.9, the conduit between the instrument transformer enclosure/compartment and the meter cabinet shall be as short as practicable and shall not be installed underground.

(b) Notwithstanding the above requirement, where special written approval is obtained from BC Hydro, the instrument transformer enclosure/compartment and meter cabinet may be located indoors provided:

- They are located in a room with a door leading directly to the exterior of the building;
- The accessibility arrangements for the exterior door are agreed upon by BC Hydro prior to approval.

The meter cabinet access arrangements would typically require a lock box similar to a commercial building meter room.

In accordance with section 5.9, where the instrument transformer enclosure/compartment is located indoors, the meter cabinet shall be located indoors in the same room as the instrument transformer enclosure/compartment.

5.1.2.2 Other 3 Phase Services

3 phase services, other than detached single family residential, shall be metered with either:

- A wall mounted **instrument transformer enclosure** and **meter cabinet** in accordance with section 5.3; or
- A switchgear **instrument transformer compartment** and **meter cabinet** in accordance with section 5.4; or
- A pole mounted **transrack** and **meter cabinet** in accordance with section 5.6.

In accordance with section 5.9, where the instrument transformer enclosure/compartment is located indoors, the meter cabinet shall be located indoors in the same room as the instrument transformer enclosure/compartment.

5.2 Schematic Drawings

Instrument transformer metering shall be installed in accordance with the schematic drawings in this section. The drawings illustrate a “main service box”. For sub service applications, substitute a “sub service disconnect device” for the “main service box” and remove the neutral ground at the “sub service disconnect device”.

5.2.1 120/240 V, 1 Phase, 3 Wire Service – Instrument Transformer Enclosure or Compartment

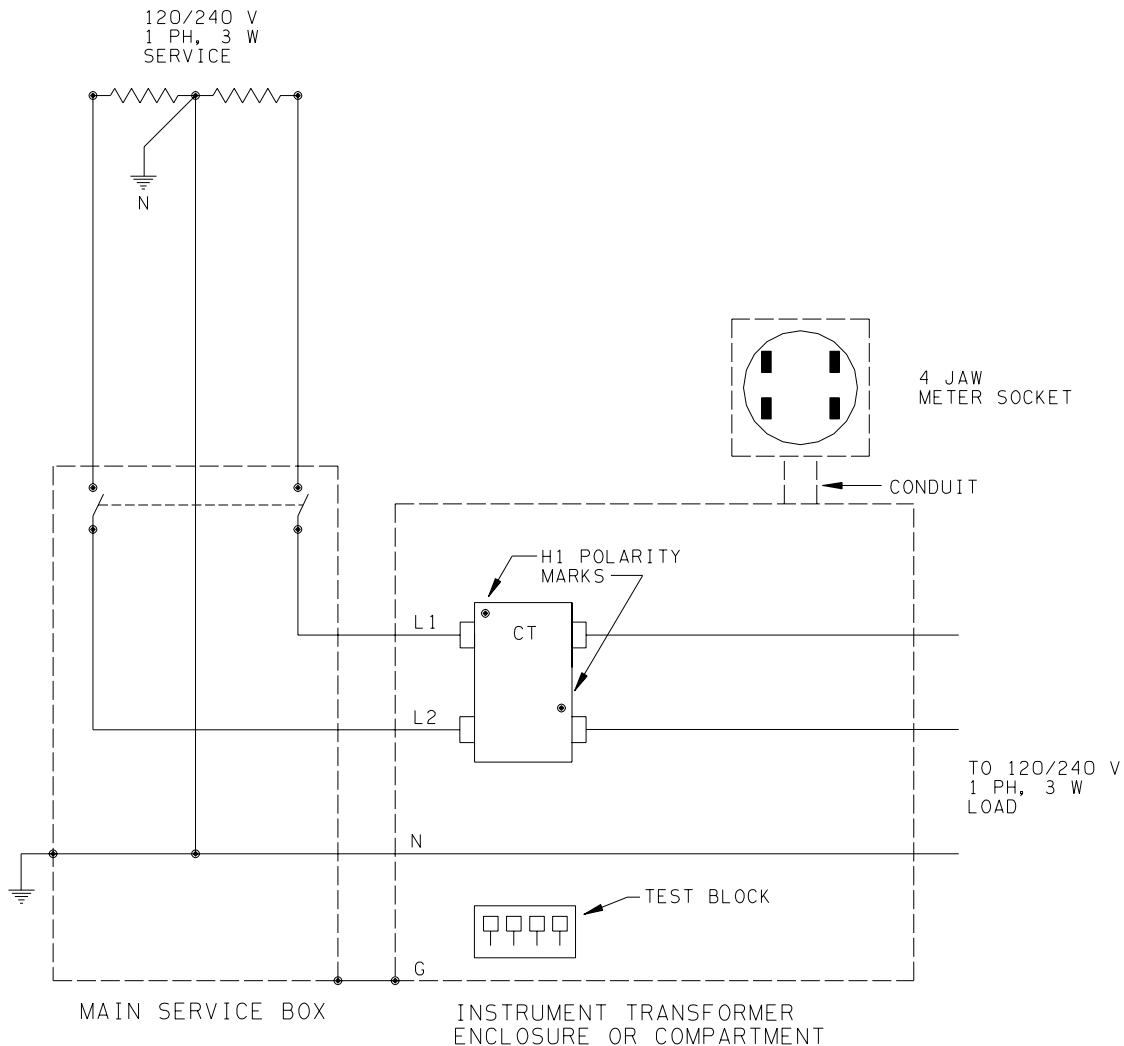

Notes:

1. See section [5.3.2.1](#).
2. Test Block - An unobstructed space of 300 mm (W) x 280 mm (H) (12" x 11") shall be provided, within the instrument transformer enclosure, for the BC Hydro supplied and installed test block.

5.2.2 120/240 V, 1 Phase, 3 Wire Service – 400 A Meter Socket Assembly, with an Integral CT

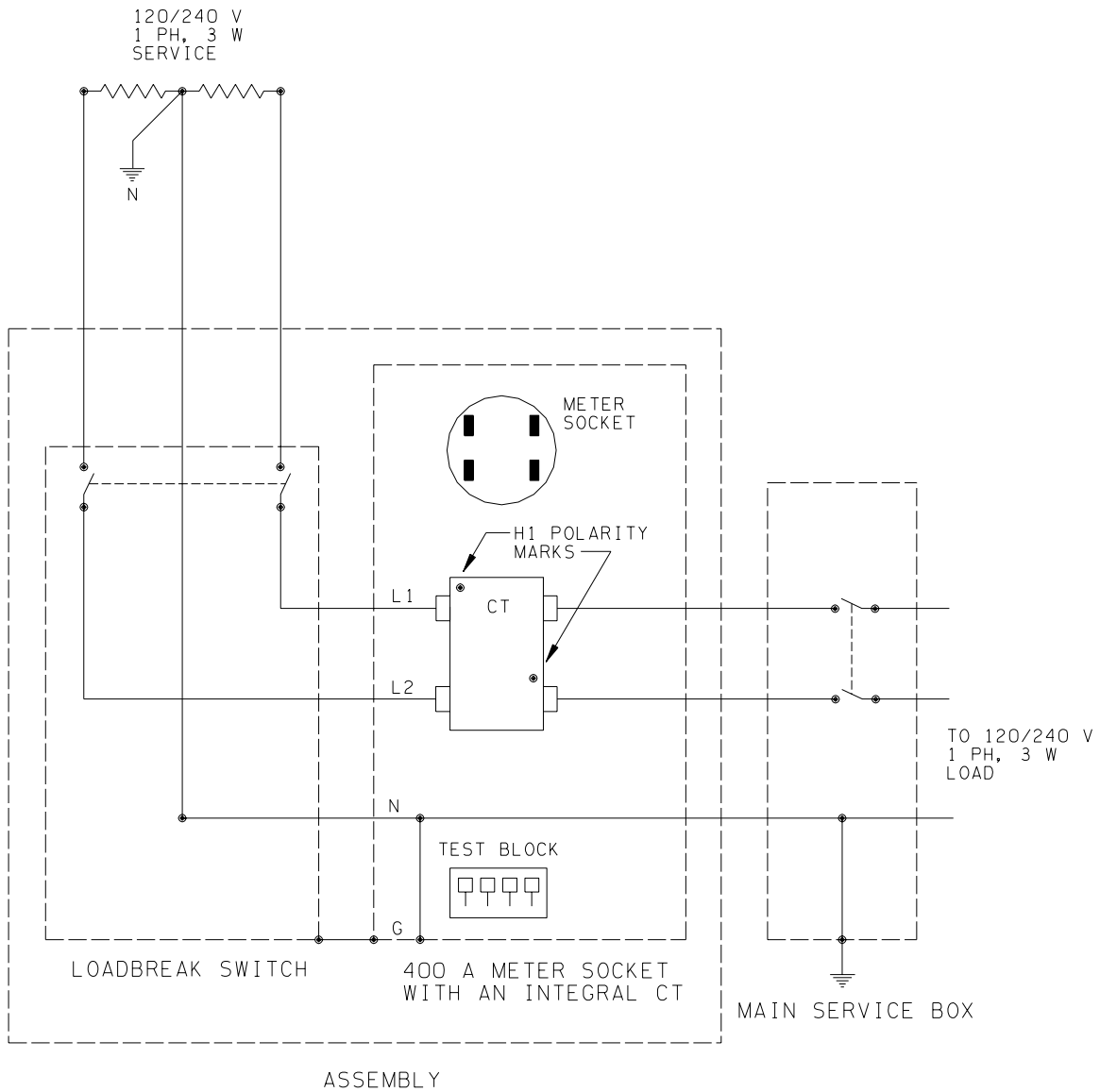

Notes:

1. See section [5.5](#).

5.2.3 120/208Y V, 3 Phase, 4 Wire Service

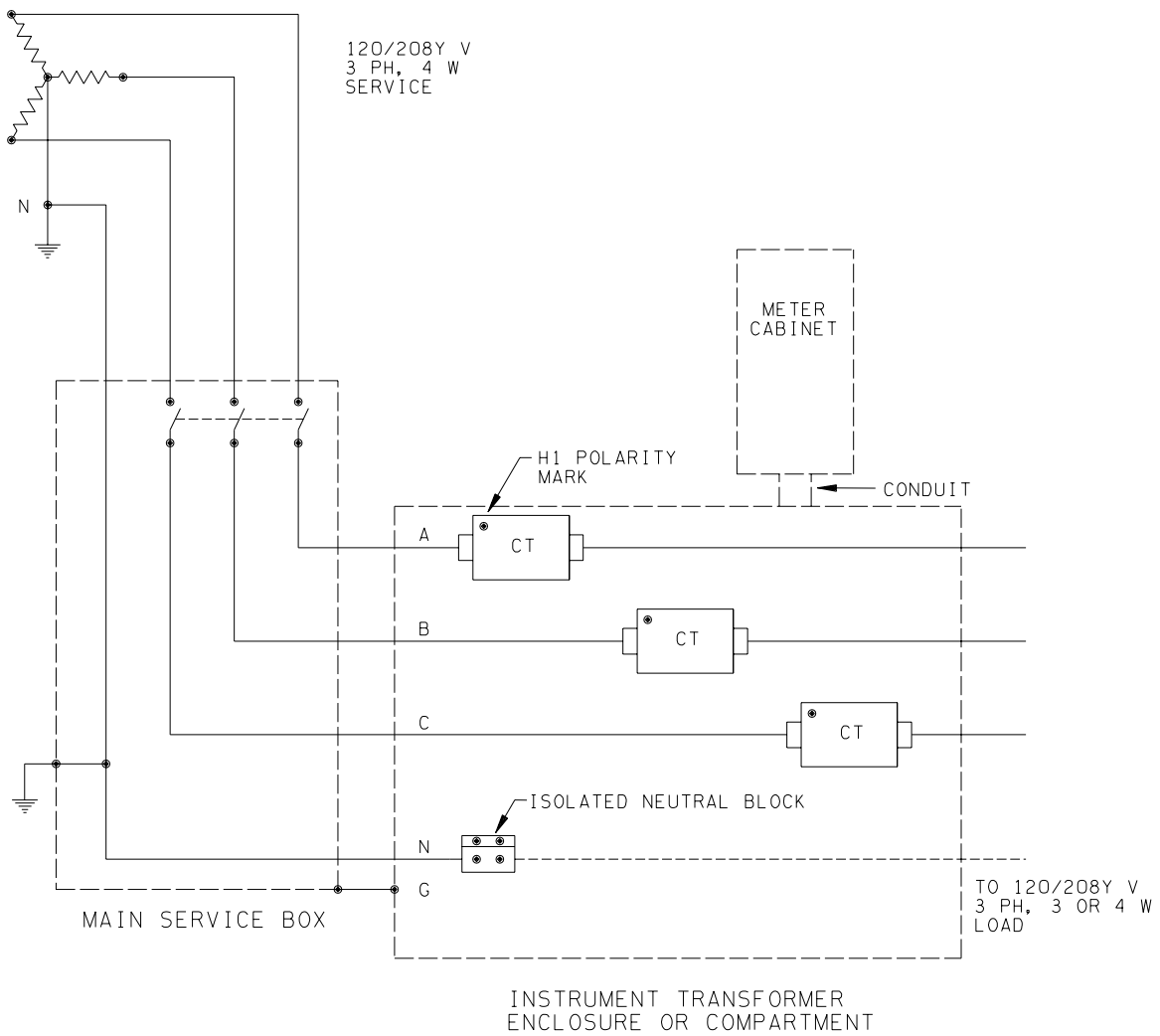

Notes

1. See section [5.3.2.2](#) and [5.3.2.3](#).

5.2.4 277/480Y V or 347/600Y V, 3 Phase, 4 Wire Service

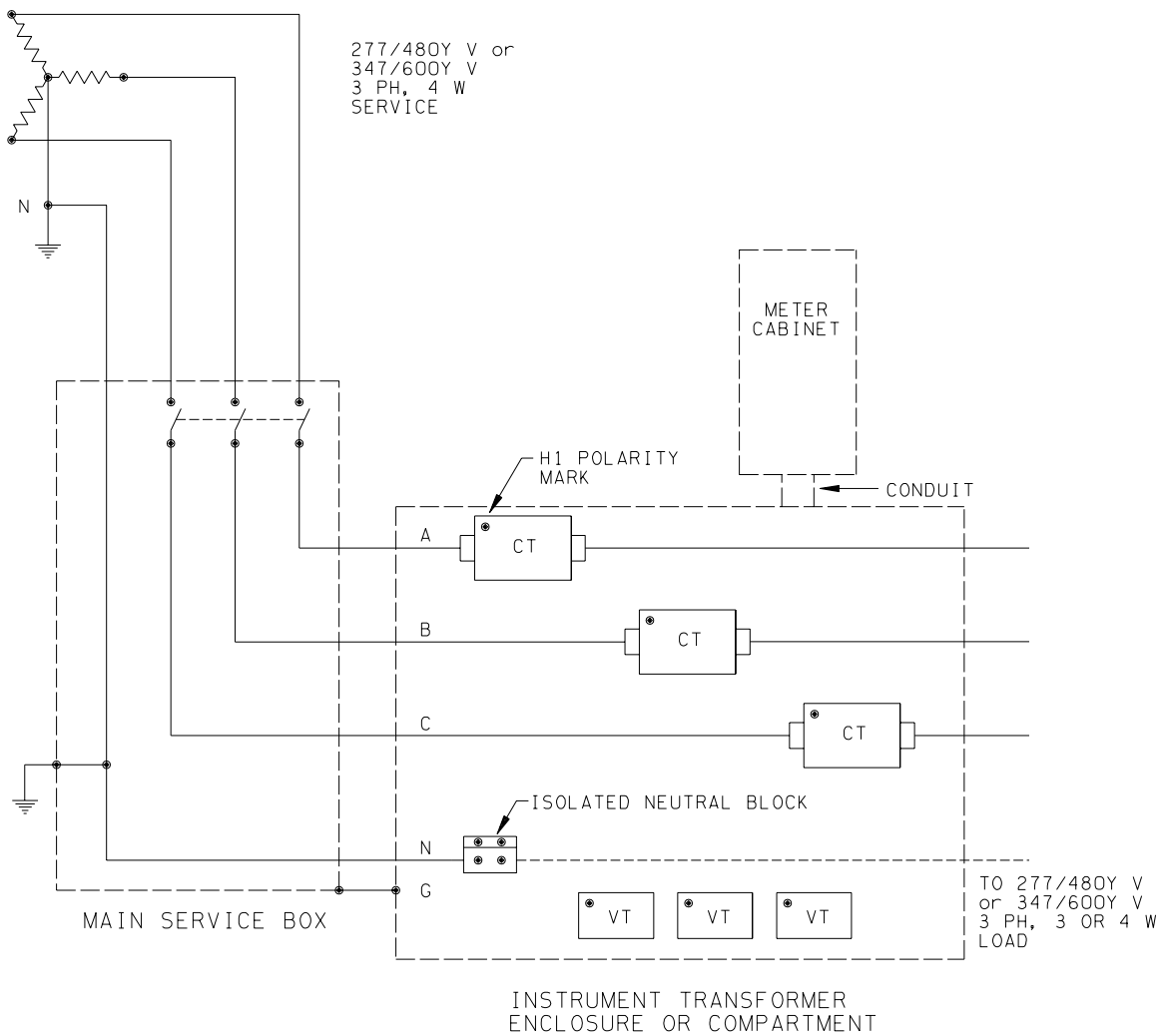

Notes:

1. See section [5.3.2.2](#) and [5.3.2.3](#).
2. BC Hydro will supply the VTs, CTs and meter for either a 277/480Y V or a 347/600Y V 3 phase, 4 wire service. However, BC Hydro does not supply the power transformers for a 277/480Y V, 3 phase, 4 wire service.

5.2.5 240 V, 3 Phase, 3 Wire Delta Service

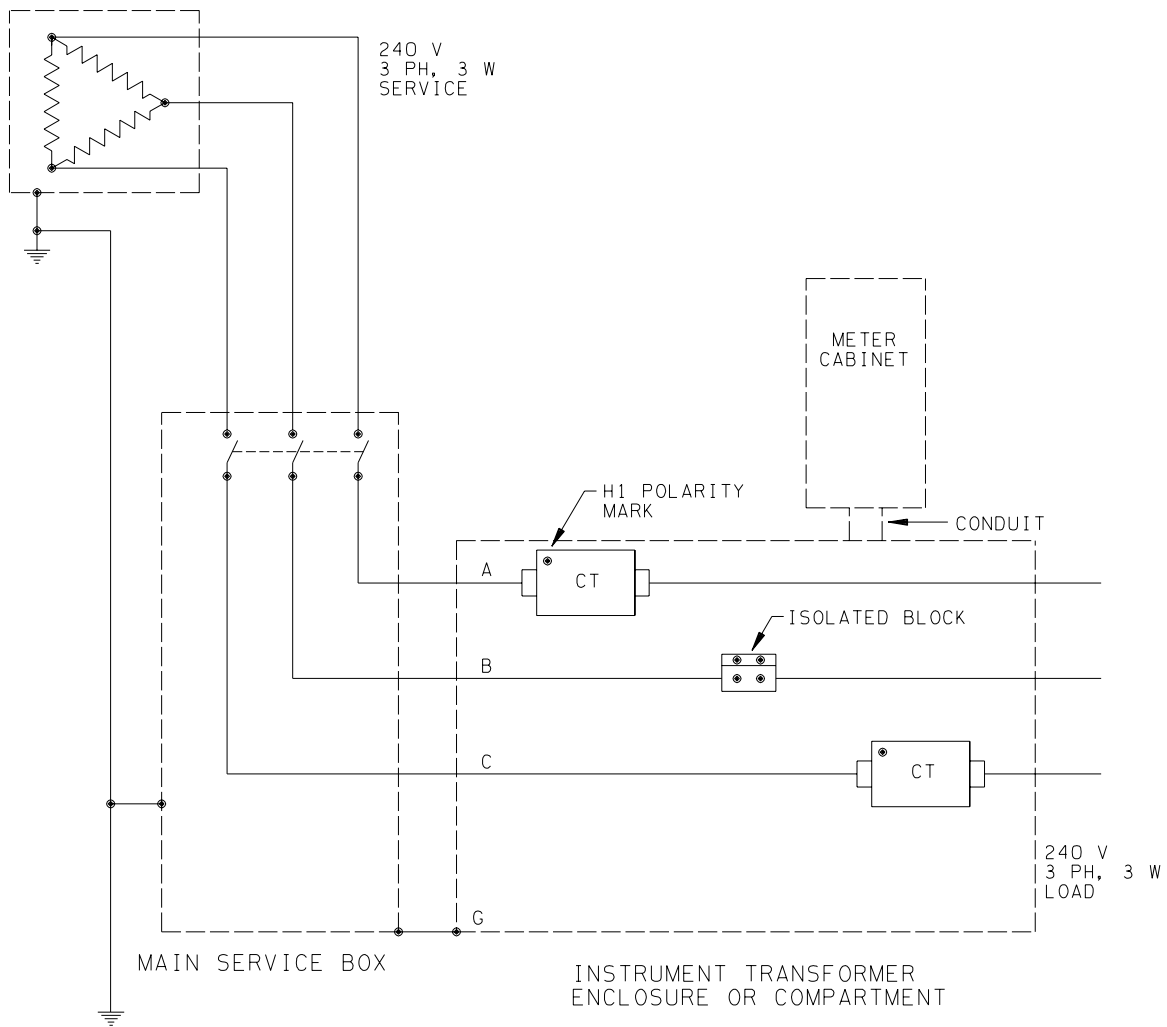

Notes:

1. See section [5.3.2.4](#).
2. BC Hydro does not supply the power transformers for this service. However, if the Customer provides the power transformers, BC Hydro will supply the CTs and meter.

5.2.6 480 V or 600 V, 3 Phase, 3 Wire Delta Service

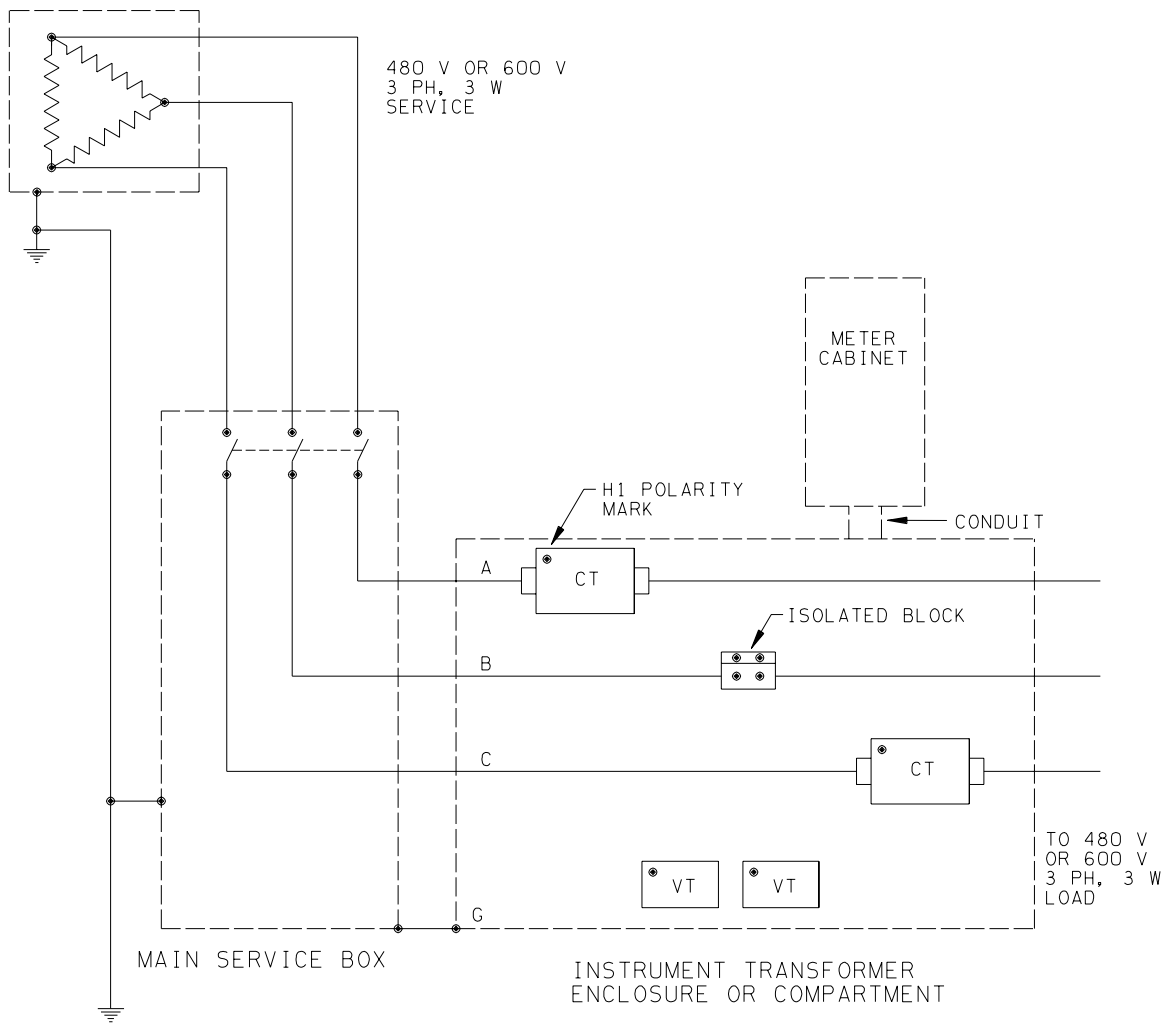

Notes:

1. See section [5.3.2.4](#).
2. BC Hydro does not supply the power transformers for either of these services. However, if the Customer provides the power transformers, BC Hydro will supply the VTs, CTs and meter.

5.3 Wall Mounted Instrument Transformer Enclosure

5.3.1 Responsibility

5.3.1.1 1 Phase

(a) The **Customer** shall:

- Supply and install a wall mounted instrument transformer enclosure; and
- Supply and install a 100 A, 4 jaw meter socket in accordance with section 4.1 and 4.24.2; and
- Supply and install a conduit between the instrument transformer enclosure and the meter socket in accordance with section 5.9; and
- Install the CTs in accordance with section 5.7; and
- Make the CT primary connections in accordance with section 5.7.

(b) **BC Hydro** will:

- Supply the CTs; and
- Supply and install the meter, test block and metering wiring.

5.3.1.2 3 Phase

(c) The **Customer** shall:

- Supply and install a wall mounted instrument transformer enclosure; and
- Install the meter cabinet in accordance with section 5.8; and
- Supply and install a conduit between the instrument transformer enclosure and the meter cabinet in accordance with section 5.9; and
- Install the CTs in accordance with section 5.7; and
- Make the CT primary connections in accordance with section 5.7; and
- Where the phase-to-phase voltage is over 300 V, install the VTs in accordance with section 5.7.

(d) **BC Hydro** will:

- Supply the meter cabinet; and
- Supply the CTs; and
- Where the phase-to-phase voltage is over 300 V:
 - Supply the VTs; and
 - Make the VT primary connections; and
- Supply and install the meter, test block and metering wiring.

5.3.2 Equipment

(a) The instrument transformer enclosure shall:

- Not be used as a splitter; and
- Not contain devices other than the BC Hydro metering equipment; and
- Be on the load side of the main service box or sub service disconnect device; and
- Be adjacent to the main service box or sub service disconnect device; and
- Be as close as practicable to the main service box or sub service disconnect device; and
- Where located indoors, be in the same room as the main service box or sub service disconnect device; and
- Be as close as practicable to the meter socket/cabinet (*See section 5.9 for the maximum separation distance*); and
- Where located indoors, be in the same room as the meter socket/cabinet; and
- For 1 phase installations, be in accordance with the dimensional and other requirements of section 6.10; and
- For 3 phase installations, be in accordance with the dimensional and other requirements of section 6.11; and
- Have a flanged or hinged cover with provision for installation of BC Hydro wire seals; and
- Be permanently labelled as “BC Hydro Metering”; and
- Have provision for terminating a bonding conductor, within the enclosure, with either:
 - A 10-32 bonding screw and washer; or
 - A mechanical connector suitable for a #12 to #8 AWG conductor.

The use and location of an instrument transformer enclosure for detached single family residential services is restricted See section, 5.1.

(b) The main service box or sub service disconnect device shall have provision for being locked open with a 8 mm (5/16”) shank padlock.

(c) For each point-of-metering, the same unique identifier shall be permanently and legibly marked on each of the following:

- Main service box or sub service disconnect; and
- Instrument transformer enclosure; and
- Meter socket/cabinet.

In accordance with WorkSafe BC regulations, it is essential that each instrument transformer enclosure point-of-isolation and meter socket/cabinet is explicitly and unambiguously identified to insure that it can be safely disconnected and locked out.

(d) Where there is a potential for back energization from the load side of the instrument transformer enclosure:

- Written approval shall be obtained from BC Hydro; and
- A lockable disconnect device shall be provided on the load side of the instrument transformer enclosure; and
- The load side disconnect device shall meet the same requirements as the line side main service box or the line side sub service disconnect device; and
- A warning notice shall be installed in a conspicuous place near the instrument transformer enclosure; and
- A permanent, legible single-line diagram shall be installed in a conspicuous place near the instrument transformer enclosure.

Examples of the potential for back energization include:

- *Where, by special permission from BC Hydro, there are multiple services and/or points of metering and there is the potential for switching loads between them;*
- *Where, by special permission from BC Hydro, the Customer has power generation that may be synchronized and/or closed transition momentarily connected to BC Hydro.*

However, where the Customer has generation connected via a CSA approved transfer switch, no potential for back energization is deemed to exist and only a line side disconnect device is required.

5.3.2.1 120/240 V, 1 Phase, 3 Wire

- (a) For 120/240 V, 1 phase, 3 wire installations, the neutral is not part of the metering circuit.
- (b) Where a single 3 wire bar type CT is supplied, it shall be installed in accordance with section 6.12. Where two 2 wire bar type CTs are supplied, they shall be installed in accordance with section 6.13.

See also the table in section 5.7.

- (c) An unobstructed space of 300 mm (W) x 280 mm (H) (12" x 11") shall be provided, within the instrument transformer enclosure, for the BC Hydro supplied and installed test block.

5.3.2.2 3 Phase, 4 Wire Supply – 3 Phase 4 Wire Load

- (a) Where a 3 phase, 4 wire supply serves a 3 phase, 4 wire load, all neutral conductor(s) shall be routed through (i.e. in and out) the instrument transformer enclosure. A neutral tap is not acceptable.
- (b) An isolated neutral block shall be supplied. Where multiple neutral cables are used, only one of the cables is required to be connected to the isolated neutral block. The isolated neutral block shall have either a 10-32 screw and washer or it shall have a mechanical connector suitable for terminating three #12 AWG conductors. See section 6.14.

5.3.2.3 3 Phase, 4 Wire Supply – 3 Phase 3 Wire Load

- (a) Where a 3 phase, 4 wire supply serves a 3 phase, 3 wire load, the neutral shall be extended to the instrument transformer enclosure. The minimum size of the neutral extension shall be #2 AWG.
- (b) The neutral extension shall terminate at an isolated neutral block. The isolated neutral block shall have either a 10-32 screw and washer or it shall have a mechanical connector suitable for terminating three #12 AWG conductors. See section 6.14.

5.3.2.4 3 Phase, 3 Wire Supply and Load

An isolated block shall be supplied for B phase. Where multiple cables are used, only one of the B phase cables is required to be connected to the isolated block. The isolated block shall have either a 10-32 screw and washer or it shall have a mechanical connector suitable for terminating two #12 AWG conductors.

5.4 Switchgear Instrument Transformer Compartment

5.4.1 Responsibility

5.4.1.1 1 Phase

(a) The **Customer** shall:

- Supply and install a switchgear instrument transformer compartment; and
- Supply and install a 100 A, 4 jaw meter socket in accordance with section [4.1](#) and [4.2](#); and
- Supply and install a conduit between the switchgear instrument transformer compartment and the meter socket in accordance with section [5.9](#); and
- Install the CTs in accordance with section [5.7](#); and
- Make the CT primary connections in accordance with section [5.7](#).

(b) **BC Hydro** will:

- Supply the CTs; and
- Supply and install the meter, test block and metering wiring.

5.4.1.2 3 Phase

(a) The **Customer** shall:

- Supply and install a switchgear instrument transformer compartment; and
- Install the meter cabinet in accordance with section [5.8](#); and
- Supply and install a conduit between the switchgear instrument transformer compartment and the meter cabinet in accordance with section [5.9](#); and
- Install the CTs in accordance with section [5.7](#); and
- Make the CT primary connections in accordance with section [5.7](#); and
- Where the phase-to-phase voltage is over 300 V, install the VTs in accordance with section [5.7](#).

(b) **BC Hydro** will:

- Supply the meter cabinet; and
- Supply the CTs; and
- Where the phase-to-phase voltage is over 300 V:
 - Supply the VTs; and
 - Make the VT primary connections; and
- Supply and install the meter, test block and metering wiring.

5.4.2 Equipment

(a) The switchgear instrument transformer compartment shall:

- Be barriered off from other compartments; and
- Not be used as a splitter; and
- Not contain devices other than the BC Hydro metering equipment; and
- Be on the load side of the main service box or sub service disconnect device; and
- Be as close as practicable to the main service box or sub service disconnect device; and
- Where located indoors, be in the same room as the main service box or sub service disconnect device; and
- Be as close as practicable to the meter socket/cabinet (*See section 5.9 for the maximum separation distance*); and
- Where located indoors, be in the same room as the meter socket/cabinet; and
- Be of sufficient size to provide acceptable access for the installation and removal of the instrument transformers; and
- Provide a minimum of 155 mm clearance between the top of the VTs and any barrier or obstruction; and
- Not have a depth greater than 610 mm; and
- Not require access through other compartments; and
- Have a hinged cover with provision for the installation of a BC Hydro wire seal; and
- Be permanently labelled as “BC Hydro Metering”; and
- Have provision for terminating a bonding conductor, within the compartment, with either:
 - A 10-32 bonding screw and washer; or
 - A mechanical connector suitable for a #12 to #8 AWG conductor.

Where, the BC Hydro service is at a primary voltage level (4 kV to 35 kV), the main service box or sub service disconnect device may be on the primary of the Customers power transformer.

The overall dimension of the instrument transformer compartment is not specified.

The use and location of an instrument transformer compartment for detached single family residential services is restricted See section 5.1.

(b) The CTs shall be 600 mm to 1800 above the floor level.

This only applies to the mounting height of the CTs within the instrument transformer compartment. The bottom and top of the instrument transformer compartment may be lower or higher.

(c) The main service box or sub service disconnect device shall have provision for being locked open with an 8 mm (5/16") shank padlock.

(d) For each point-of-metering, the same unique identifier shall be permanently and legibly marked on each of the following:

- Main service box or sub service disconnect; and
- Instrument transformer compartment; and
- Meter socket/cabinet.

In accordance with WorkSafe BC regulations, it is essential that each instrument transformer compartment point-of-isolation and meter socket/cabinet is explicitly and unambiguously identified to insure that it can be safely disconnected and locked out.

(e) Where there is a potential for back energization from the load side of the instrument transformer compartment:

- Written approval shall be obtained from BC Hydro; and
- A lockable disconnect device shall be provided on the load side of the instrument transformer compartment; and
- The load side disconnect device shall meet the same requirements as the line side main service box or the line side sub service disconnect device; and
- A warning notice shall be installed in a conspicuous place near the instrument transformer compartment; and
- A permanent, legible single-line diagram shall be installed in a conspicuous place near the instrument transformer compartment.

Examples of the potential for back energization include:

- *Where, by special permission from BC Hydro, there are multiple services and/or points of metering and there is the potential for switching loads between them;*
- *Where, by special permission from BC Hydro, the Customer has power generation that may be synchronized and/or closed transition momentarily connected to BC Hydro.*

However, where the Customer has generation connected via a CSA approved transfer switch, no potential for back energization is deemed to exist and only a line side disconnect device is required.

5.4.2.1 120/240 V, 1 Phase, 3 Wire

- (a) For 120/240 V, 1 phase, 3 wire installations, the neutral is not part of the metering circuit.
- (b) Where a single 3 wire bar type CT is supplied, it shall be installed in accordance with section 6.12. Where two 2 wire bar type CTs are supplied, they shall be installed in accordance with section 6.13.

See also the table in section 5.7.

- (c) An unobstructed space of 300 mm (W) x 280 mm (H) (12" x 11") shall be provided, within the instrument transformer compartment, for the BC Hydro supplied and installed test block.

5.4.2.2 3 Phase, 4 Wire Supply – 3 Phase 4 Wire Load

(a) Where a 3 phase, 4 wire supply serves a 3 phase, 4 wire load;

- The neutral bus shall be routed through (i.e. in and out) the instrument transformer compartment; or
- A rigid neutral bus tap shall be provided from the neutral bus to the instrument transformer compartment. The rigid neutral bus tap shall not be less than 25 mm x 6 mm (1" x 1/4").

(b) A 10-32 screw and washer shall be supplied at the following points:

- Line side of the A phase CT; and
- Line side of the B phase CT; and
- Line side of the C phase CT; and
- Neutral bus or neutral tap.

5.4.2.3 3 Phase, 4 Wire Supply – 3 Phase 3 Wire Load

(a) Where a 3 phase, 4 wire supply serves a 3 phase, 3 wire load, the neutral bus shall be extended to the instrument transformer compartment. The rigid neutral bus extension shall not be less than 25 mm x 6 mm (1" x 1/4").

(b) A 10-32 screw and washer shall be supplied at the following points:

- Line side of the A phase CT; and
- Line side of the B phase CT; and
- Line side of the C phase CT; and
- Neutral bus extension.

5.4.2.4 3 Phase, 3 Wire Supply and Load

A 10-32 screw and washer shall be supplied at the following points:

- Line side of the A phase CT; and
- B phase; and
- Line side of the C phase CT.

5.5 120/240 V, 1 Phase, 400 A Meter Socket Assembly, with an Integral CT

For new services connected after December 1, 2007, a BC Hydro listed assembly, with a load break switch on the line side of the meter socket, is mandatory.

5.5.1 Responsibility

New services connected prior to December 1, 2007 may be in accordance with sections (a) and (b) or sections (c) and (d).

(a) The **Customer** shall:

- Supply and install a 120/240 V, 1 Phase, 400 A meter socket, with provision for an integral CT; and
- Install the CT in accordance with section 5.7; and
- Make the CT primary connections in accordance with section 5.7.

(b) **BC Hydro** will:

- Supply the CT; and
- Supply and install the meter, test block and metering wiring.

New services connected after December 1, 2007 shall be in accordance with sections (c) and (d) only.

(c) The **Customer** shall:

- Supply and install a 120/240 V, 1 Phase, 400 A meter socket **assembly**, with provision for an integral CT; and
- Install the CT in accordance with section 5.7; and
- Make the CT primary connections in accordance with section 5.7.

(d) **BC Hydro** will:

- Supply the CT; and
- Supply and install the meter, test block and metering wiring.

5.5.2 Equipment

New services connected prior to December 1, 2007 may be in accordance with sections (a) to (e) or sections (f) to (l).

- (a) The 400 A meter socket shall be installed outdoors on the line side of the main service box with the neutral bonded.
- (b) If the 400 A meter socket is wall mounted, it shall be one of the following approved models:
- Hydel CT4-BC c/w lexan barrier; or
 - T&B Microelectric JS4B-4STW c/w lexan barrier.
- (c) If the 400 A meter socket is pole mounted, it shall be one of the following approved models complete with the manufacturer supplied pole mounting kit:
- Hydel CT4-BC c/w lexan barrier plus CT4PMK36 pole mounting kit; or
 - T&B Microelectric JS4B-4STW c/w lexan barrier plus PMB-JS4 pole mounting kit.

Any unused mounting holes shall be closed to prevent moisture or insect ingress.

The manufacturer supplied pole mounting kit insures that the 400 A meter socket is securely attached to the pole. Attaching "wall mount" 400 A meter sockets directly to a pole with lag bolts or using a site fabricated bracket is prohibited.

- (d) The 400 A meter socket shall be mounted with the centre of the meter socket 1500 mm to 1800 mm above finished grade.
- (e) The 400 A meter socket bottom panel shall be secured with screws that require a tool for removal.

Access to energized conductors, in the bottom panel, shall not rely only on the presence of the BC Hydro seal and/or padlock.

New services connected after December 1, 2007 shall be in accordance with sections (f) to (l) only.

(f) The 400 A meter socket assembly consists of a:

- 400 A meter socket with an integral CT; and
- A Load break switch on the line side of the meter socket.

See the schematic in section 5.2.2.

(g) The 400 A meter socket assembly shall be listed by BC Hydro. Currently listed 400 A meter socket assemblies include:

- Overhead Service
 - Gescan BCHGT 400-0V / BCHGH 400-0V
 - Beaver Electric SE401GHO / SE401GTO
- Underground Service
 - Gescan BCHGT 400-B / BCHGH 400-B
 - Beaver Electric SE401GTB / SE401GHB

(h) The 400 A meter socket assembly shall be in accordance with section 6.17.

(i) The 400 A meter socket assembly shall be:

- Installed outdoors on the line side of the main service box; and
- Either pole or wall mounted; and
- Mounted with the centre of the meter socket 1500 mm to 1800 mm above finished grade.

(j) The 400 A meter socket assembly load break switch:

- Is to permit isolation of the CT; and
- Is for BC Hydro use only; and
- Is not accessible by the customer; and
- Is not an overcurrent device; and
- Is not part of the main service box.

(k) In accordance with section 10-624 of the Canadian Electrical Code, the neutral shall be bonded to the 400 A meter socket.

- (l) The 400 A meter socket bottom panel shall be secured with screws that require a tool for removal.

Access to energized conductors, in the bottom panel, shall not rely only on the presence of the BC Hydro seal and/or padlock.

5.6 Pole Mounted Transrack

See section [6.18](#) and contact BC Hydro for details.

5.7 Instrument Transformers

- (a) At 300 V phase-to-phase and less, current transformers (CTs) only are required. At greater than 300 V phase-to-phase, CTs and voltage transformers (VTs) are required.

BC Hydro typically supplies the following CTs for permanent installations.

Location	Supply System	Min Current	Max Current	Qty	Type	Section
Indoor	120/240 V 1 Phase 3 Wire	300 A	800 A	1	3 Wire Bar *	6.12
		1000 A	1200 A	2	2 Wire Bar	6.13
	3 Phase 3 Wire	300 A	1200 A	2	2 Wire Bar	-
		1500 A	6000 A	2	Window	6.15
	3 Phase 4 Wire	300 A	1200 A	3	2 Wire Bar	6.14
		1500 A	6000 A	3	Window	6.15
Outdoor	120/240 V 1 Phase 3 Wire	300 A	800 A	2	Donut	6.16 6.18
		300 A	800 A	2	Donut	6.16 6.18
	3 Phase 4 Wire	300 A	800 A	3	Donut	6.16 6.18

Donut CTs may be available for temporary master indoor installations.

However, the Customer should check with BC Hydro to determine exactly which CTs will be supplied for their installation.

When BC Hydro supplies bar-type CTs for instrument transformer enclosures, they typically also supply the primary conductor connectors.

** A 3 Wire Bar CT has 4 primary connections.*

- (b) The CT H1 primary terminal polarity marks shall be on the line side (towards BC Hydro) in accordance with the schematic drawings in section 5.2.
- (c) The CT shall be mounted, using the provided CT base holes, to the rear wall of the instrument transformer enclosure/compartment.

“Hanging” window style CTs from the conductor, or using the primary terminals to support bar style CTs, is not permitted. Mounting CTs to the side, top or bottom walls of the instrument transformer enclosure/compartment is not permitted.

- (d) The conductors shall be shaped and supported to insure that strain is not applied to the CTs.
- (e) The VT and CT primary winding terminals and secondary winding terminals shall remain accessible and the nameplates shall remain visible. The installation shall facilitate the easy replacement of the VTs and CTs.

While nameplates must remain visible, terminal accessibility and polarity orientation may position the nameplate upside-down or sideways. This is acceptable.

5.8 Meter Cabinet

- (a) The meter cabinet shall be installed, in a readily accessible location approved by BC Hydro, in accordance with section 3 and section 5.1.

The meter cabinet shall be as close as practicable to the instrument transformer enclosure/compartments and in the same room as the instrument transformer enclosure/compartments. See section 5.9 for the maximum separation distance. For detached single family residential services, section 5.1, requires that both the instrument transformer enclosure/compartments and the meter cabinet be located outdoors.

- (b) One meter cabinet is required for each 3 phase instrument transformer point-of-metering.
- (c) The meter cabinet tilt shall not exceed 3° from vertical.

5.8.1 Indoor Installations

- (a) The BC Hydro stock number 372-9206 meter cabinet, shown in section 6.19 and 6.20, is used for indoor installations.

- (b) The meter cabinet shall be wall mounted with the door hinge on the left or the right side only.

With the hinge on the right, the door lettering will be upside down. This is acceptable.

- (c) The top of the meter cabinet shall be mounted between 1,630 mm to 1,930 mm above the finished grade.

A mounting height of 1,800 mm above finished grade is preferred.

- (d) The installation shall permit self tapping screws, installed by BC Hydro to mount devices within the meter cabinet, to project through the rear wall.
- (e) The meter cabinet shall be removable.

-
- (f) The meter cabinet shall be mounted, using all four predrilled holes, on either:
- 19 mm ($\frac{3}{4}$ ") plywood backing; or
 - Metal support channels.

The plywood or metal support channels shall be securely fastened to the wall. Shooting, or otherwise mounting the meter cabinet, directly to the wall is not permitted.

- (g) The conduit shall enter the meter cabinet from the bottom or from the side, within 75 mm of the bottom.

5.8.2 Outdoor Installations

- (a) Typical outdoor meter cabinets include:

Mounting	BC Hydro Stock Number	See Section
Wall	372-9207	<u>6.21</u>
Pole	372-9204	<u>6.22</u>
Pole	372-9205	Similar to 372-9204 except there is a 1070 mm mounting hole separation, rather than a 735 mm separation.

- (b) The meter cabinet shall be mounted with the door hinge on the left side only.

- (c) The top of the meter cabinet shall be mounted between 1,630 mm to 1,930 mm above finished grade. If the Customer intends to build up the grade after the meter has been installed, a platform or ramp shall be provided during the interim period. The platform shall not be less than 900 mm by 900 mm.

A mounting height of 1,800 mm above finished grade is preferred.

- (d) The installation shall permit self tapping screws, installed by BC Hydro to mount devices within the meter cabinet, to project through the rear wall.

- (e) The meter cabinet shall be removable.

- (f) For wall mounted applications, the meter cabinet shall be mounted, using all four predrilled holes located on the external "ears", on metal support channels securely fastened to the wall. Shooting, or otherwise mounting the meter cabinet, directly to the wall is not permitted.

(g) For pole mounted applications:

- The meter cabinet shall be secured to the pole with lag screws using the two holes on the U shaped angle bracket; and
- The meter cabinet shall be located on the side of the pole that is not subject to vehicle damage. If this is not practicable, protection posts shall be installed 600 mm in front of the meter cabinet, similar to those required for meter sockets See section 6.4.

(h) The conduit shall enter the meter cabinet from the bottom only.

(i) Meter cabinets shall not be installed within 1000 mm of gas meters.

5.8.3 Grounding

(a) In accordance with section 36 of the Canadian Electrical Code, an external meter cabinet ground conductor shall be provided if:

- The associated instrument transformer compartment is within a unit substation with a high voltage (greater than 750 V) section; or
- The meter cabinet is within the same room as high voltage equipment.

(b) Where required, the external meter cabinet ground conductor shall not be less than #2/0 AWG copper and shall be connected to the station ground grid electrode.

A #2/0 AWG copper conductor is required since, due to skin effect, its large surface area provides a low impedance path for high frequency electrical noise.

5.8.4 Optional Meter Compartment

- (a) As an alternative to the BC Hydro supplied meter cabinet, the Customer may provide an optional meter compartment within the switchgear that contains the instrument transformer compartment.
- (b) The optional meter compartment shall:
- Be completely separate from the instrument transformer compartment and shall have its own door; and
 - Have its top between 1,630 mm to 1,930 mm above the finished grade; and
 - Have dimensions not less than those of a BC Hydro supplied indoor meter cabinet; and
 - Have three 10° angled studs at the top of the compartment with the same spacing as those in a BC Hydro supplied indoor meter cabinet; and
 - Permit self tapping screws, installed by BC Hydro to mount devices within the optional meter compartment; to project through the rear wall; and
 - Be permanently labelled “BC Hydro Meter”.
- (c) The Customer shall provide a continuous metal conduit, without access fittings, between the optional meter compartment and the instrument transformer compartment.
- (d) The conduit shall enter the optional meter compartment from the bottom or from the side, within 75 mm of the bottom.

5.9 Conduit

- (a) The Customer shall supply and install a conduit between the meter socket/cabinet and the instrument transformer enclosure/compartment.

The meter socket/cabinet shall be as close as practicable to the instrument transformer enclosure/compartment and in the same room as the instrument transformer enclosure/compartment. For detached single family residential services, section 5.1, requires that both the instrument transformer enclosure/compartment and the meter socket/cabinet be located outdoors.

- (b) The conduit shall be either rigid metal, EMT or rigid PVC.

ENT (electrical non-metallic tubing) is not permitted.

- (c) The conduit shall have not more than the equivalent of three 90° bends.

- (d) For 1 phase installations, the conduit length shall not exceed 3 m (10') and the minimum trade size shall be 21 (3/4").

- (e) For 3 phase installations, the conduit length shall not exceed 10 m (33') and the minimum trade size shall be 35 (1 1/4"). Except that, where special written approval is first obtained from BC Hydro, a 41 (1 1/2") conduit with a length of between 10 m (33') and 25 m (82') may be installed.

- (f) The conduit shall be continuous and without access fittings. Except that, a "LB style" fitting may be installed immediately adjacent to a meter cabinet providing the cover:

- Remains clearly visible; and
- Has provision for the installation of a BC Hydro wire seal.

- (g) The conduit shall remain visible for its entire length except where it is embedded in a concrete floor within the same room.

Conduits shall not be installed through walls or underground.

- (h) For switchgear applications, where it is necessary to route the metering wiring through other switchgear compartments, in order to reach the instrument transformer compartment, the Customer shall provide a continuous metal conduit, without access fittings, within the switchgear.

- (i) The Customer shall leave a pull string in the conduit.

6. Reference Drawings

6.1 Underground Main Service Meter Sockets

Optional for new underground services connected prior to December 1, 2007

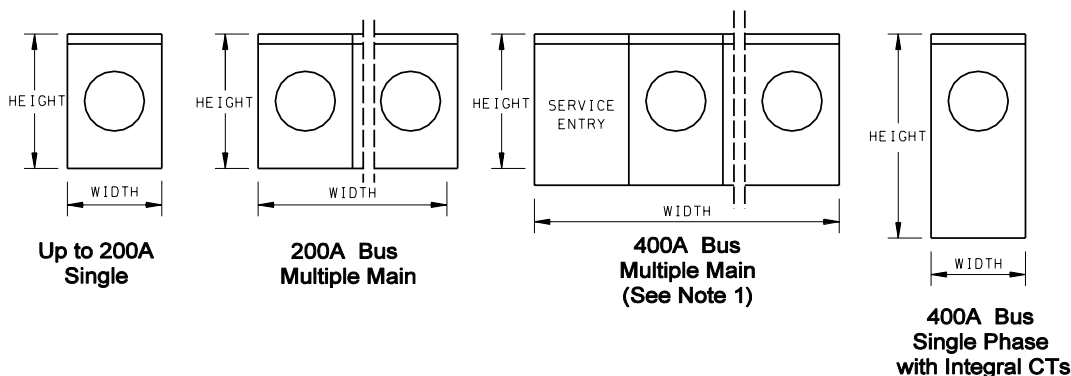

MINIMUM REQUIREMENT OF ENCLOSURES FOR METER SOCKETS

Enclosure	Sockets	Minimum Outside Dimensions			K.O. for Duct min.	Minimum Line Connector Range
		Height	Width	Depth		
Up to 200A Single	1	430	240	130	3"	#2 - 3/0 Cu #2 - 250 KCM Al
200A Main Bus	2	380	435	130	3"	#2 - 3/0 Cu #2 - 250 KCM Al
	3	380	650	130		
	4	380	870	130		
400A Main Bus (See Note 1)	2	508	665	140	4"	#1/0 - 500 KCM Cu / Al
	3	508	880	140		
	4	508	1110	140		
400A with Integral CT's	1	760	508	208	4"	#1/0 - 500 KCM Cu / Al

Notes

1. 400 A Multiple Main enclosure shall have one extra service compartment for service entry.
2. See section 3.8.
3. These requirements are applicable to underground main service meter sockets only. They are not applicable to overhead main service meter sockets or to sub service meter sockets.
4. Dimensions are in mm.

Mandatory for new underground services connected after December 1, 2007

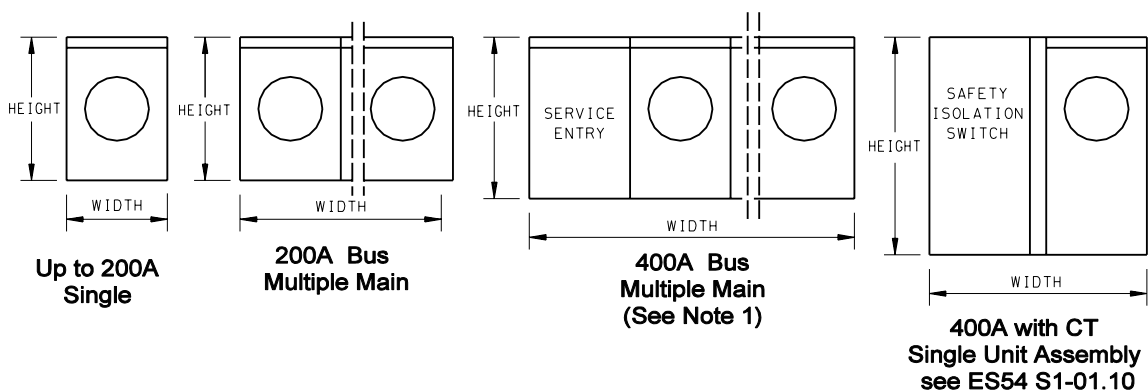

MINIMUM REQUIREMENT OF ENCLOSURES FOR METER SOCKETS

Enclosure	Sockets	Minimum Outside Dimensions			K.O. for Duct min.	Minimum Line Connector Range
		Height	Width	Depth		
Up to 200A Single	1	430	240	130	3"	#2 - 3/0 Cu #2 - 250 KCM Al
200A Main Bus	2	380	435	130	3"	#2 - 3/0 Cu #2 - 250 KCM Al
	3	380	650	130		
	4	380	870	130		
400A Main Bus (See Note 1)	2	508	665	140	3"	#1/0 - 500 KCM Cu / Al
	3	508	880	140		
	4	508	1110	140		
400A with Integral CT	1	1016	1016	222	3"	#1/0 - 500 KCM Cu / Al

NOTES:

1. 400A Multiple Main enclosures shall have one extra compartment for service entry.
2. See section 3.8.
3. These requirements are applicable to underground main service meter sockets only. They are not applicable to overhead main service meter sockets or to sub service meter sockets.
4. Dimensions are in mm.

6.2 Sealing Ring

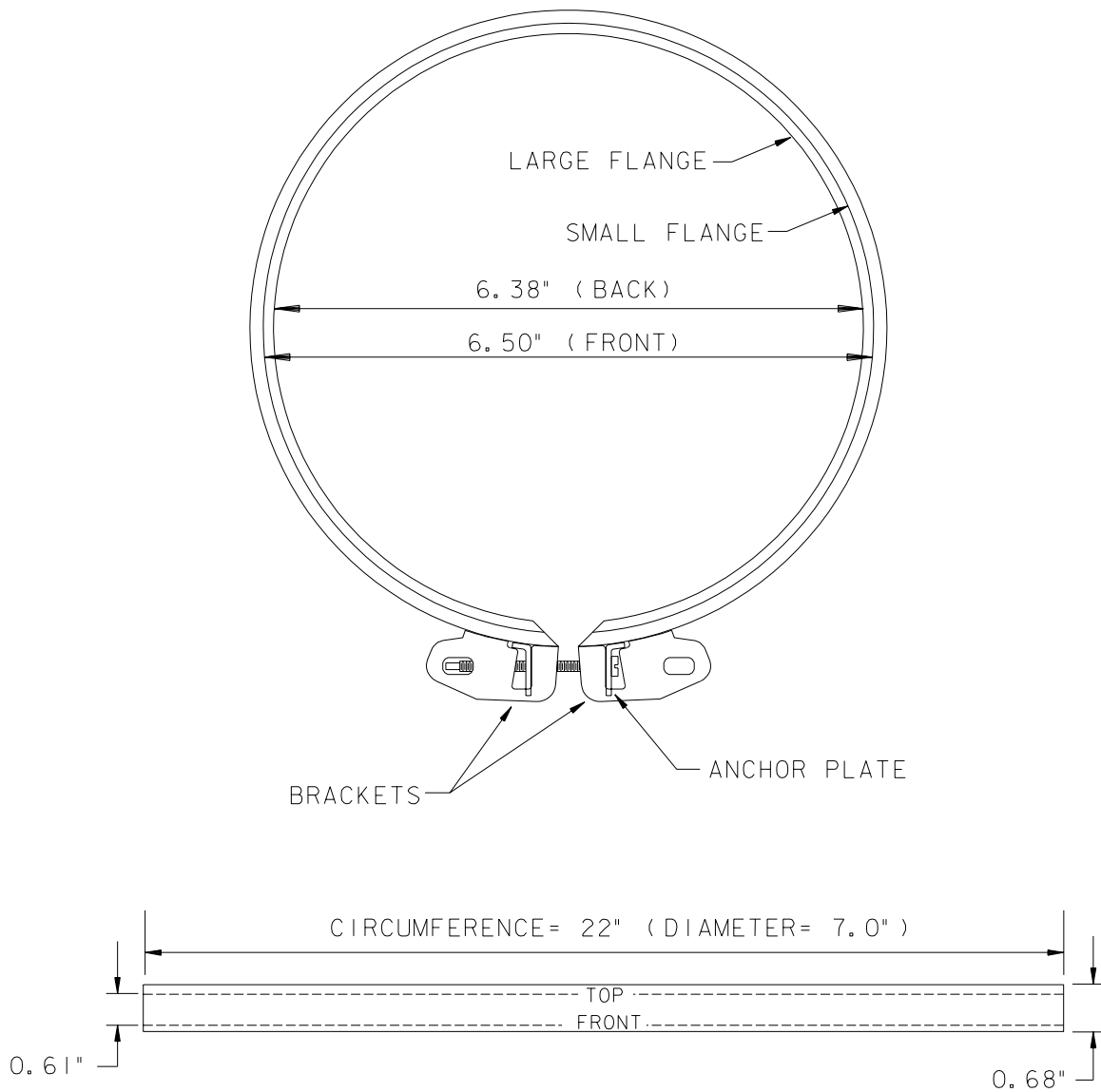

Notes:

1. See section [4.1](#).

6.3 Individual Wall Mounted Meter Socket

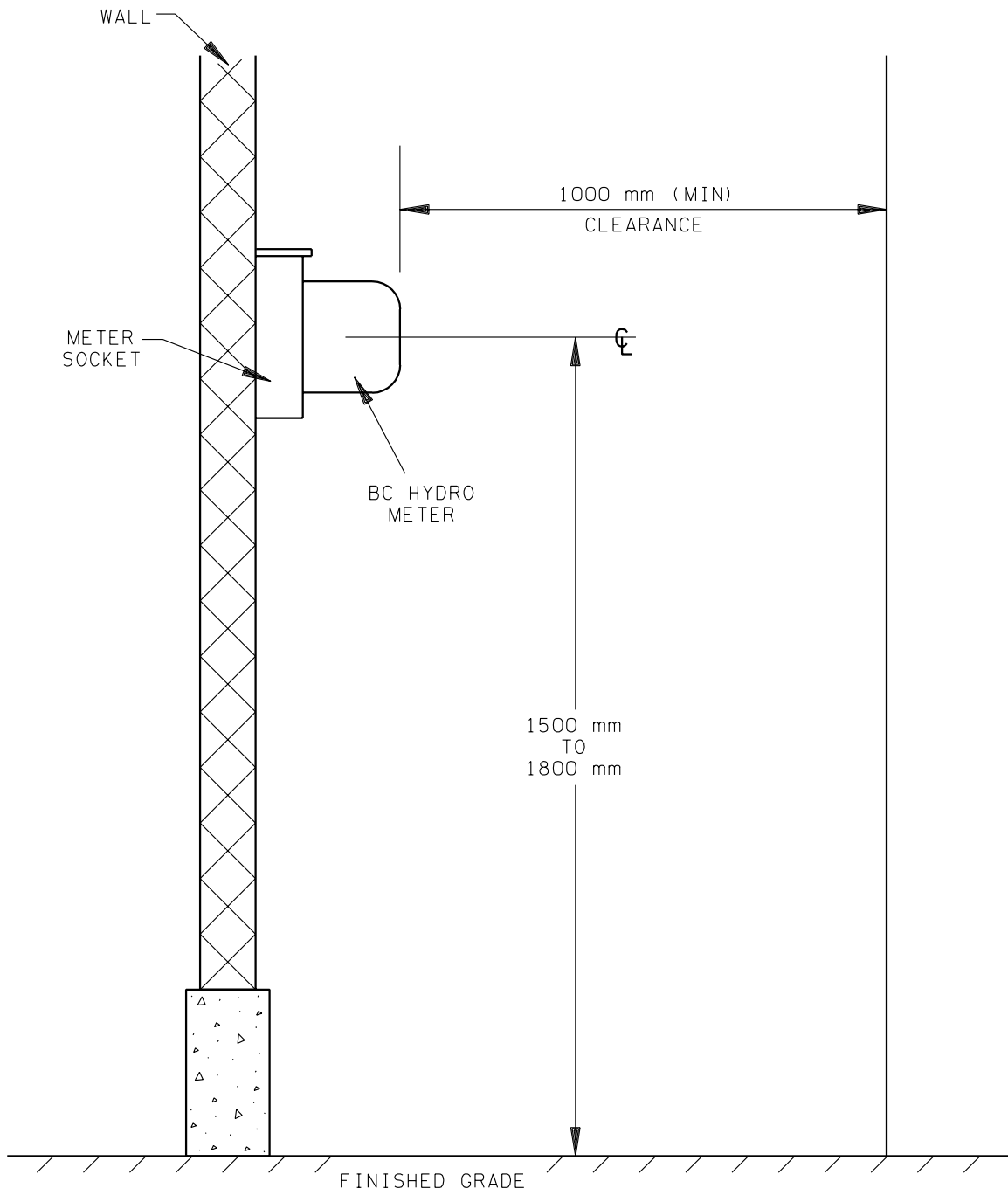

Notes:

1. See section 4.2.

6.4 Individual Pole Mounted Meter Socket

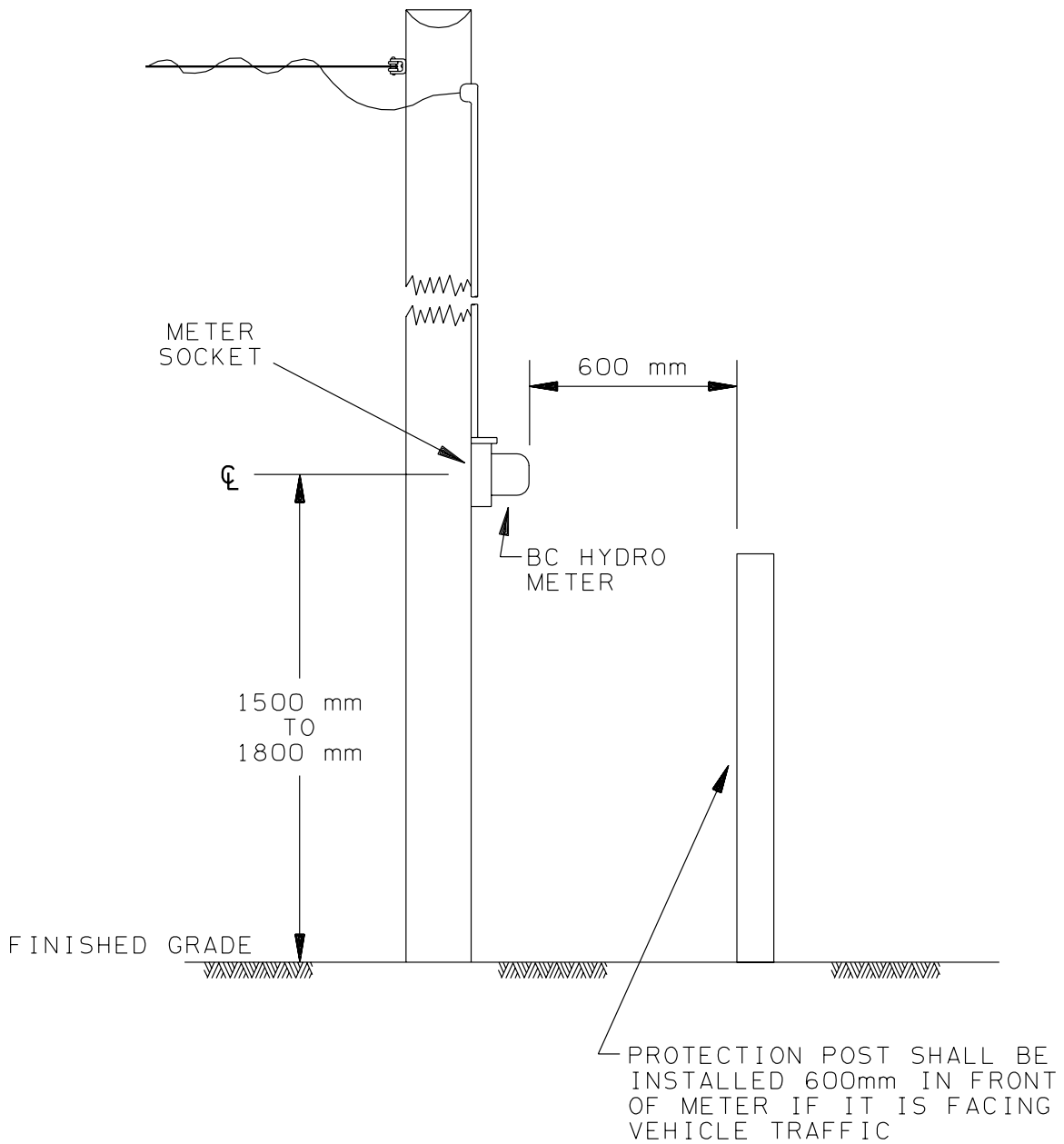

Notes:

1. See section [4.2.6](#).

6.5 Individual Wall Mounted Meter Socket Near a Gas Meter

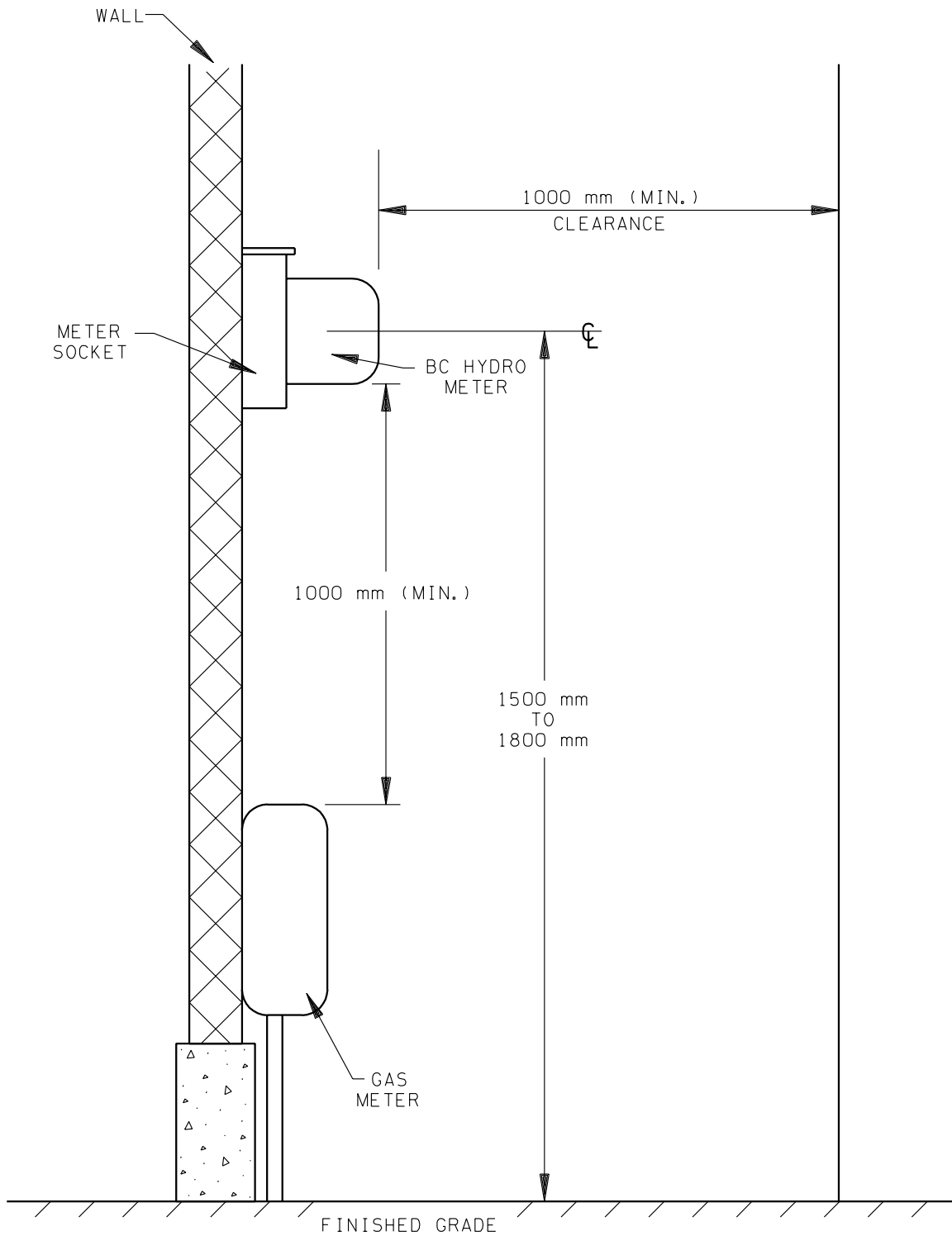

Notes:

1. See section [4.2.7](#).

6.6 Multiple Main Meter Socket

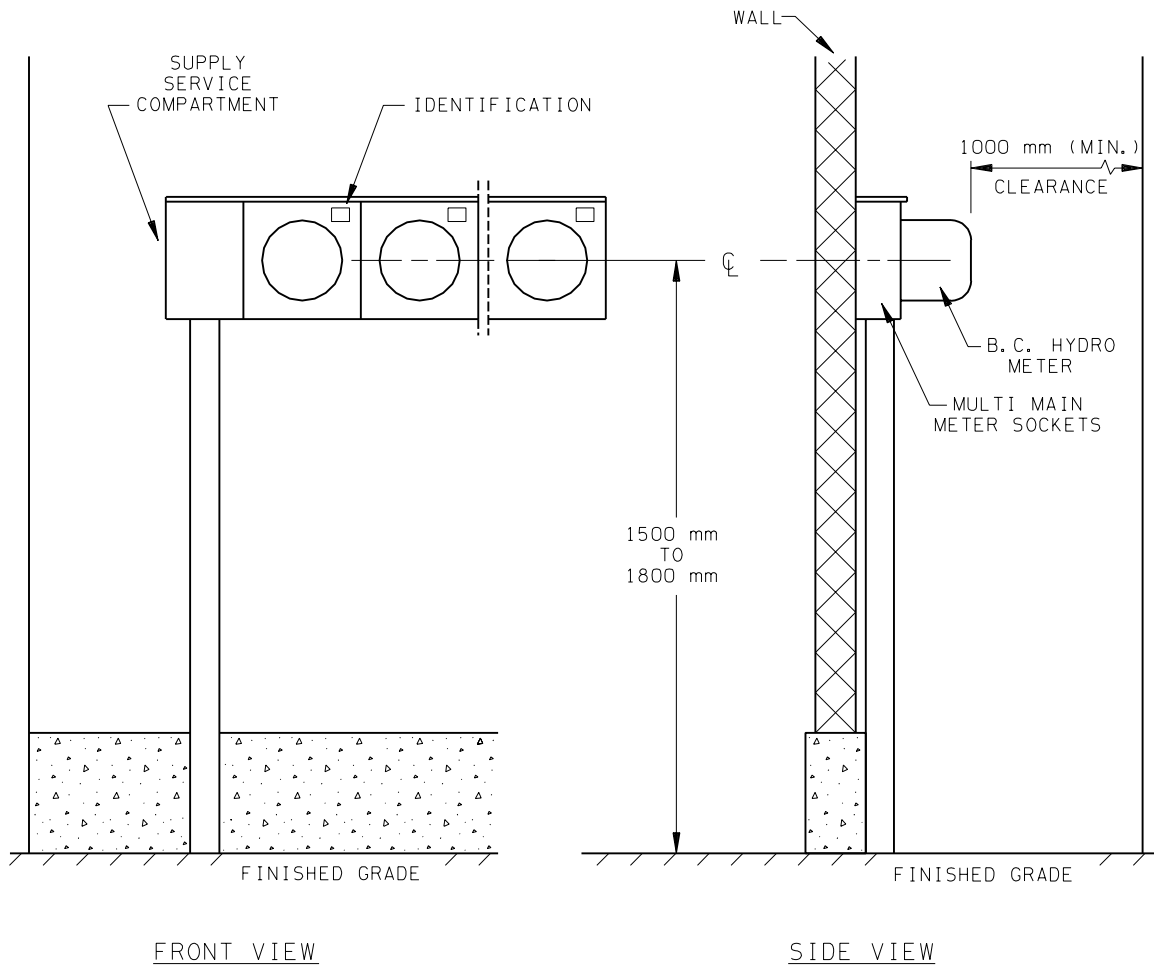

Notes:

1. See section [4.3](#).
2. Underground service illustrated.

6.7 Meter Centre

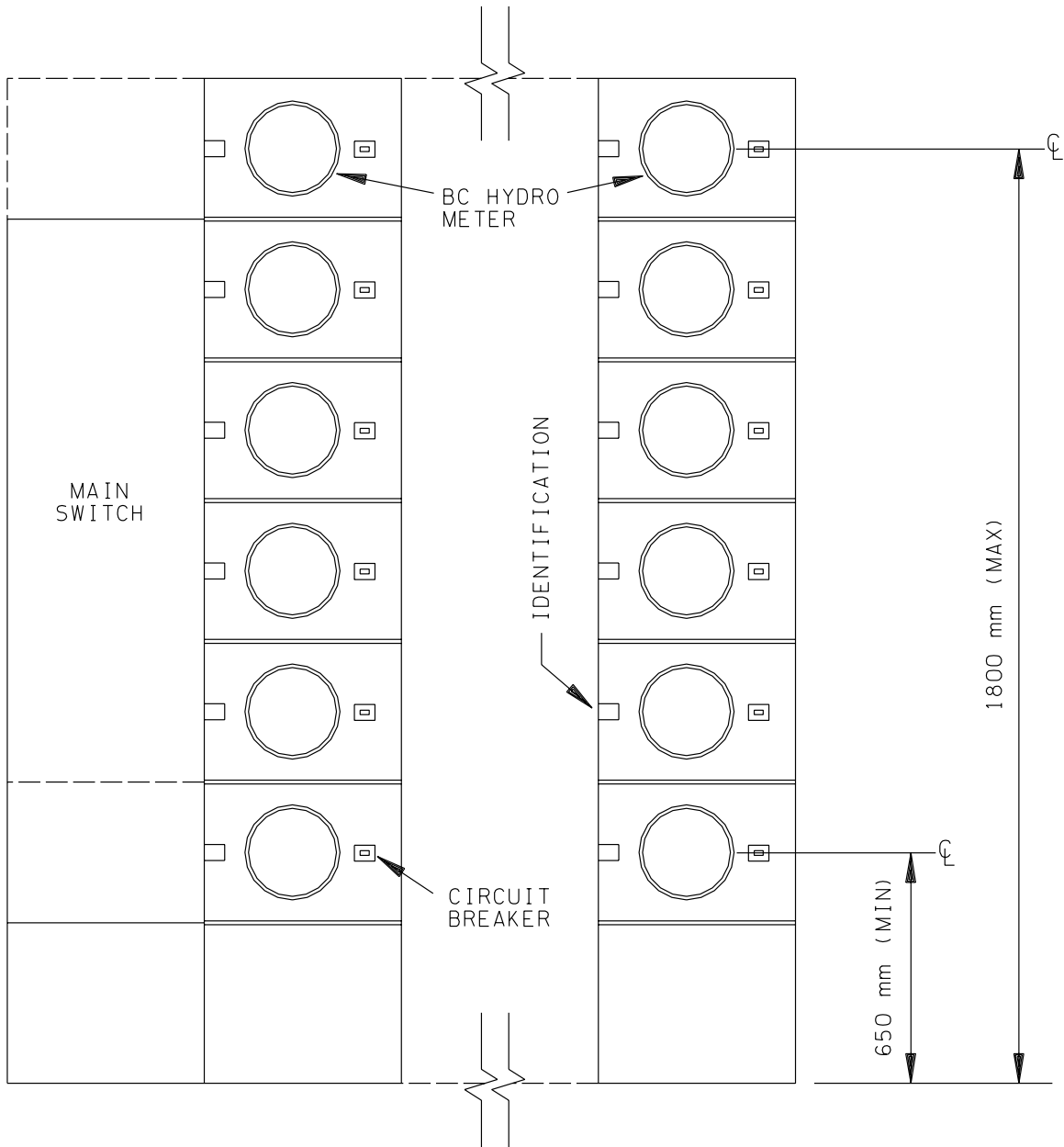

Notes:

1. See section [4.4](#).

6.8 Grouped Sub Service Metering

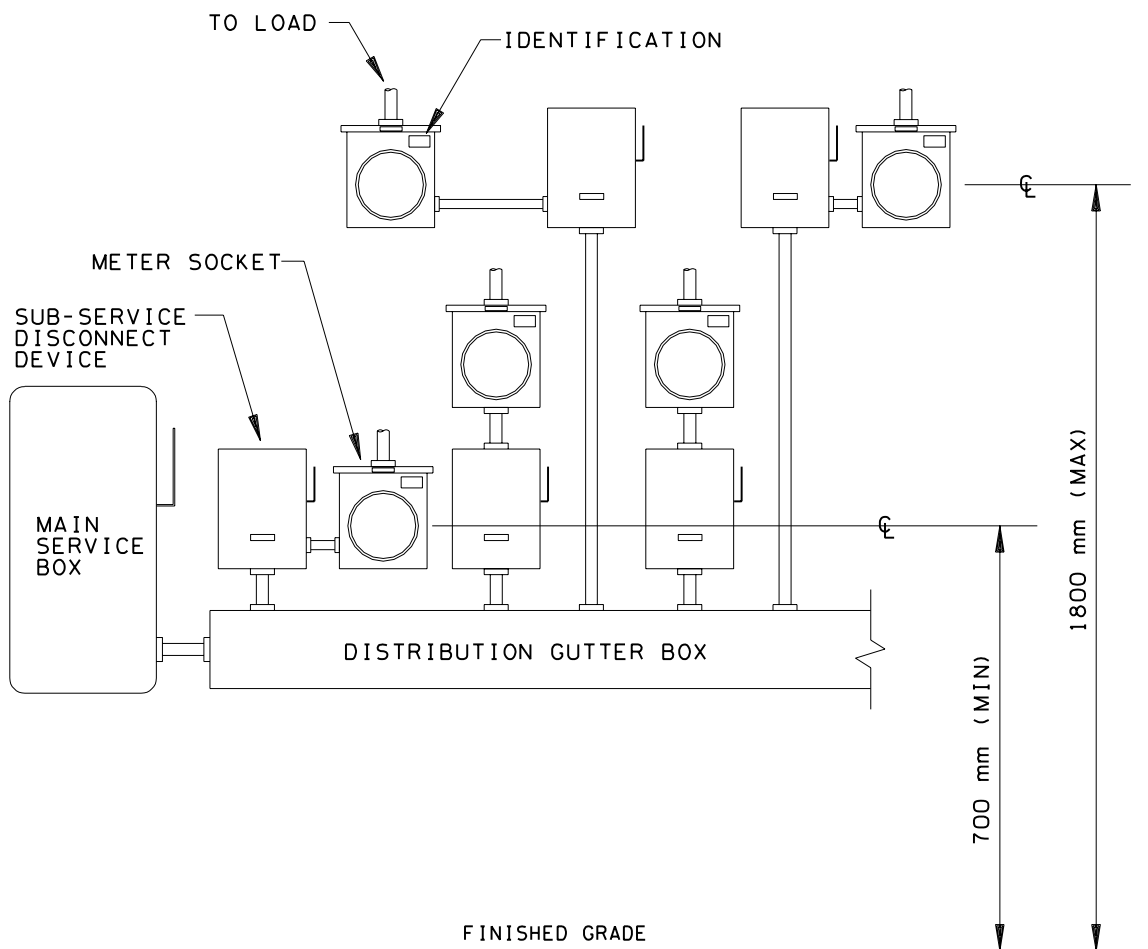

Notes:

1. See section [4.5](#).
2. Cold style metering with the meter socket on the load side of the sub service disconnect device and with the neutral isolated at the meter socket is required.
3. Each meter socket shall be adjacent to, and as close as practicable to, the controlling sub service disconnect device and in the same room as the controlling sub service disconnect device.
4. Contact BC Hydro and refer to the ES53 Series Underground Electrical standards and the ES54 Underground Civil standards for underground main service conduit, wireway and pull box requirements.

6.9 Service Pedestal

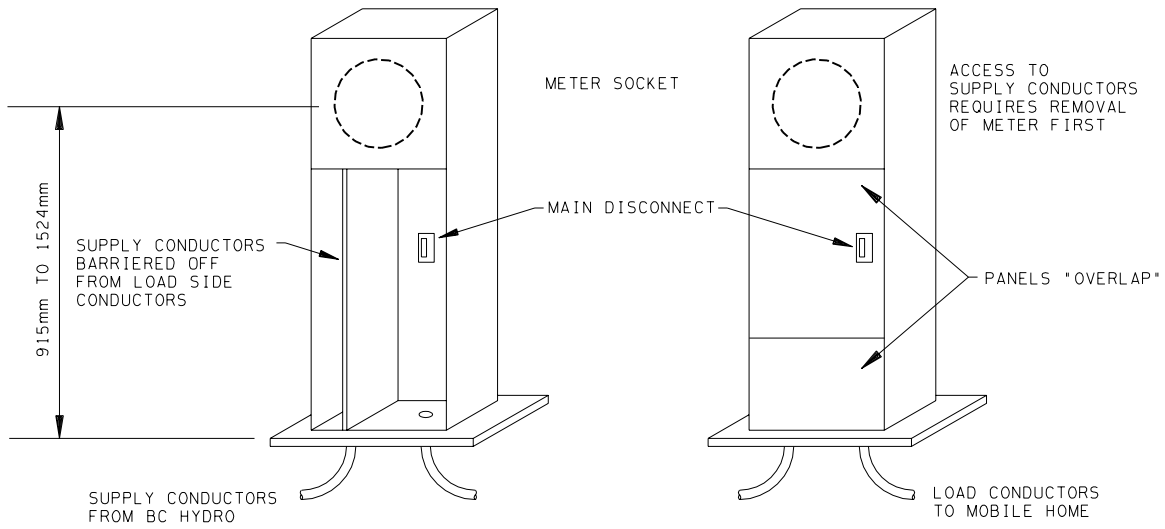

Notes:

1. See section [4.6.3](#).

6.10 120/240 V, 1 Phase, Wall Mounted Instrument Transformer Enclosure

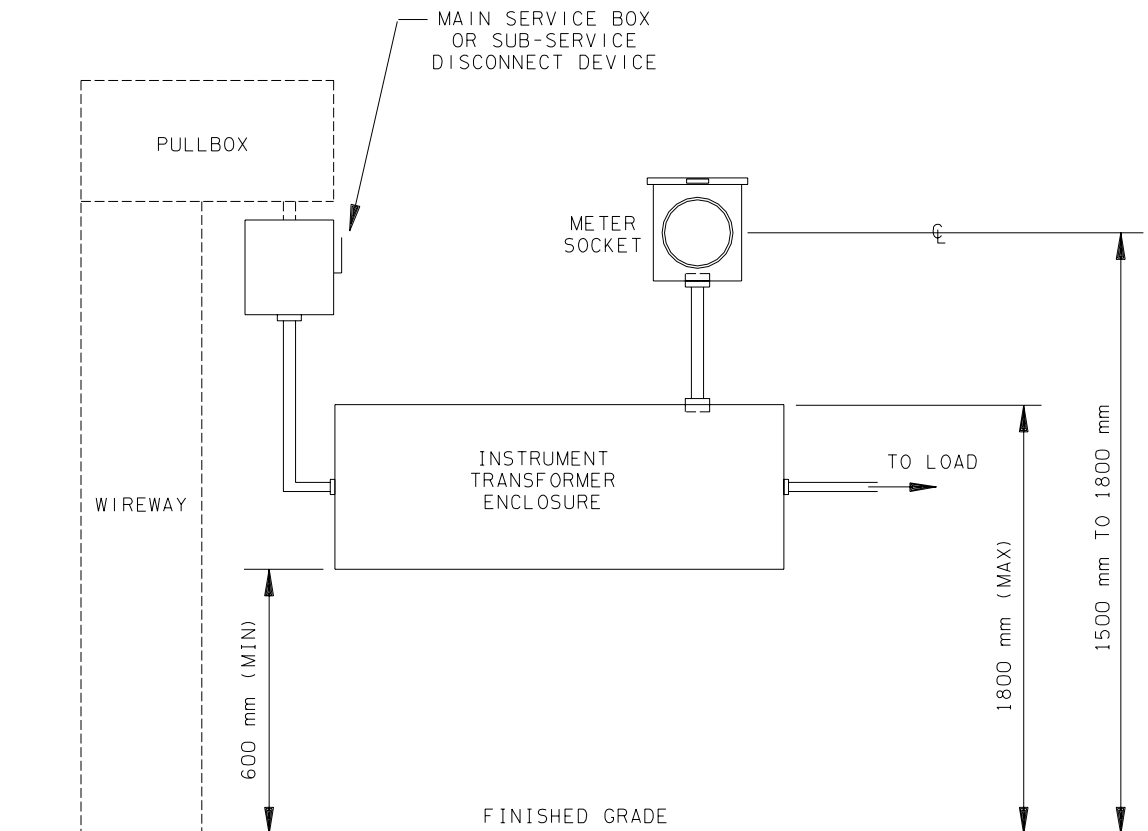

Notes:

1. See section [5.3](#).
2. The following minimum 120/240 V, 1 phase instrument transformer enclosure dimensions shall be provided.

Ampacity	Enclosure Size (W x H x D)
600 A or Less	760 mm x 420 mm x 205 mm (30" x 16" x 8")
Over 600 A	1065 mm x 460 mm x 405 mm (42" x 18" x 16")

3. An unobstructed space of 300 mm (W) x 280 mm (H) (12" x 11") shall be provided, within the instrument transformer enclosure, for the BC Hydro supplied and installed test block.
4. Illustrated equipment locations may vary provided the specified dimensions are achieved.
5. The instrument transformer enclosure shall be in the same room, adjacent to, and as close as practicable to, the main service box or sub service disconnect device.
6. The meter socket shall be in the same room, adjacent to, and as close as practicable to the instrument transformer enclosure.

-
7. Contact BC Hydro and refer to the ES53 Series Underground Electrical standards and the ES54 Underground Civil standards for underground main service conduit, wireway and pull box requirements.

6.11 3 Phase, Wall Mounted Instrument Transformer Enclosure

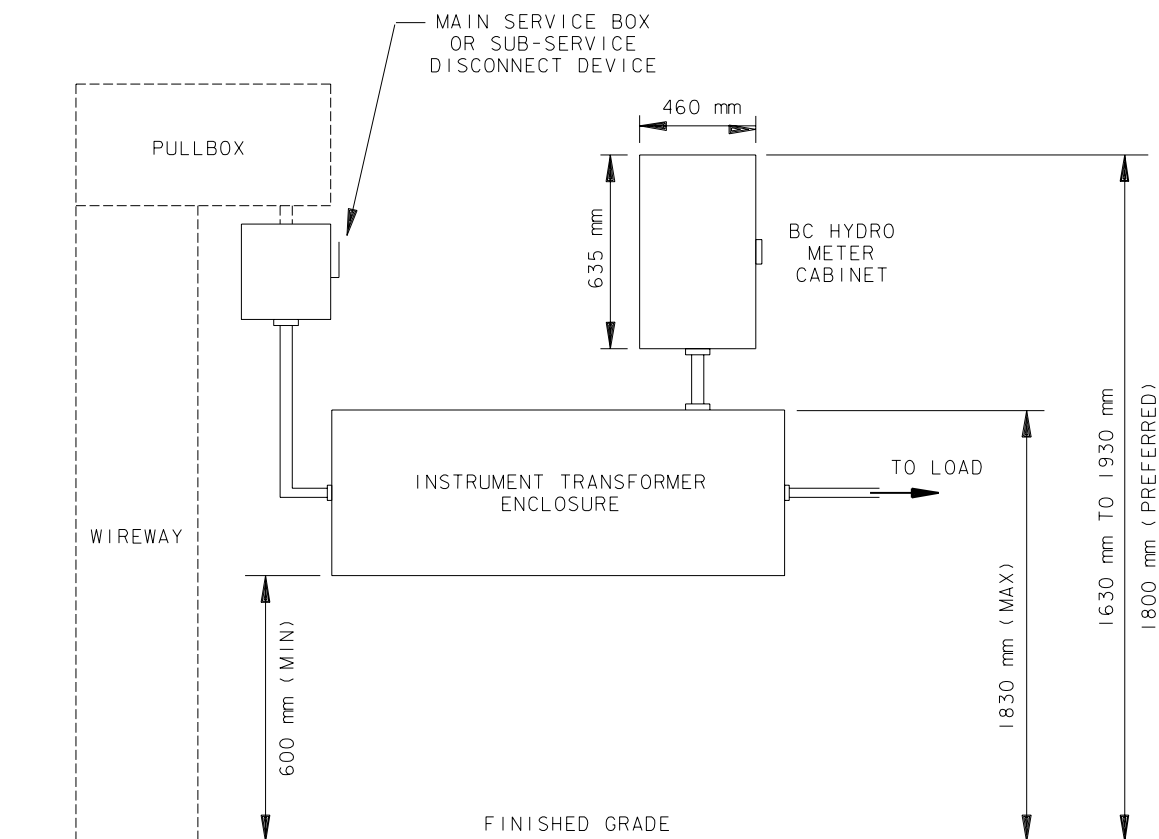

Notes:

1. See section 5.3.
2. The following minimum 3 phase instrument transformer enclosure dimensions shall be provided.

Ampacity	Voltage	Enclosure Size (W x H x D)
400 A or Less	300 V or Less	760 mm x 420 mm x 205 mm (30" x 16" x 8")
	Over 300 V	1065 mm x 460 mm x 405 mm (42" x 18" x 16")
401 A to 800 A	All	1065 mm x 460 mm x 405 mm (42" x 18" x 16")
Over 800 A	All	1065 mm x 915 mm x 610 mm (42" x 36" x 24")

3. Illustrated equipment locations may vary provided the specified dimensions are achieved.
4. The instrument transformer enclosure shall be in the same room, adjacent to, and as close as practicable to, the main service box or sub service disconnect device.

-
5. The meter cabinet shall be in the same room, adjacent to, and as close as practicable to the instrument transformer enclosure.
 6. Contact BC Hydro and refer to the ES53 Series Underground Electrical standards and the ES54 Underground Civil standards for underground main service conduit, wireway and pull box requirements.

6.12 120/240 V, 1 Phase, Metering with a Single 3 Wire Bar Type CT

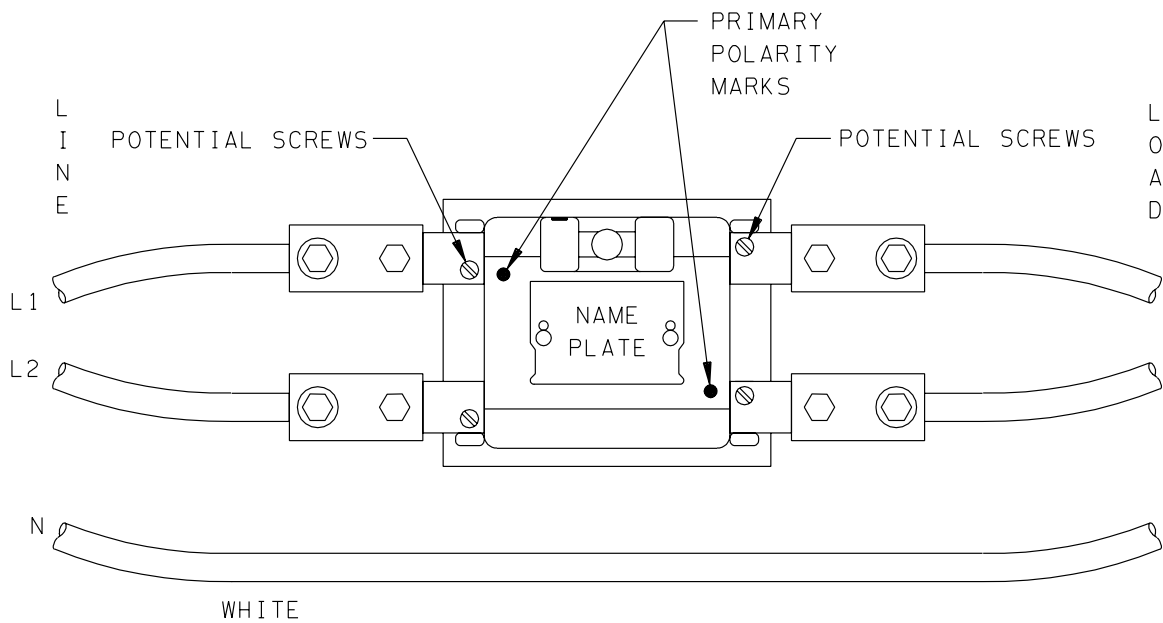

Notes:

1. See section [5.3.2.1](#).

6.13 120/240 V, 1 Phase, Metering with Two 2 Wire Bar Type CTs

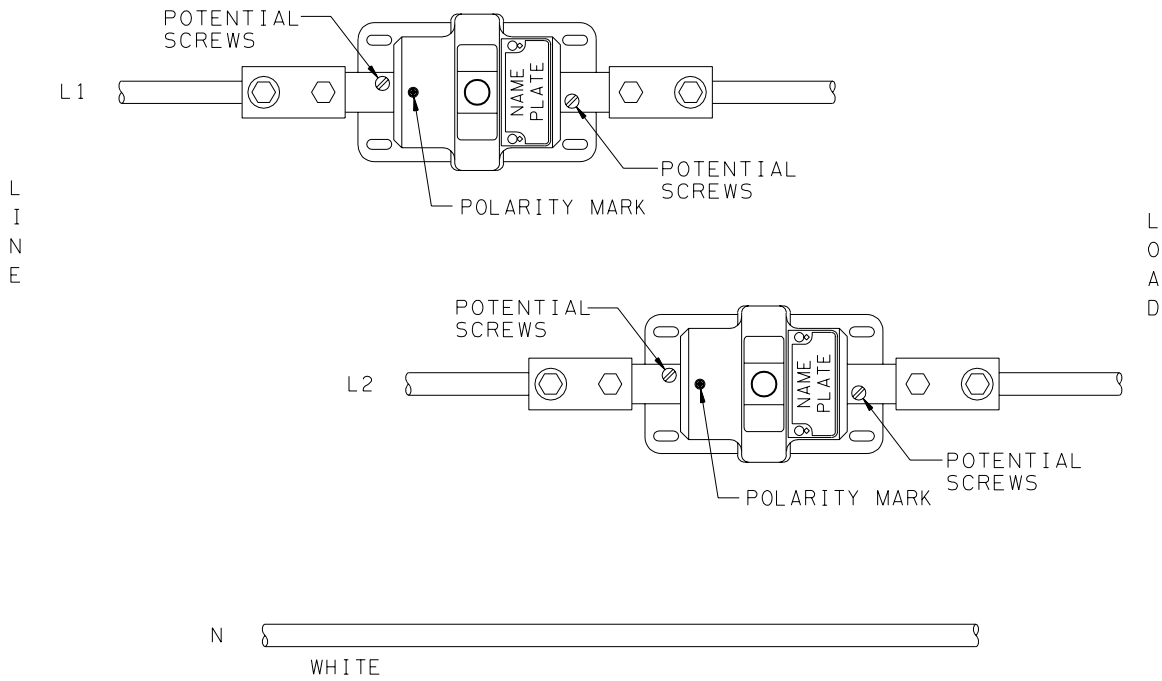

Notes:

1. See section [5.3.2.1](#).

6.14 3 Phase, 4 Wire, Metering with Bar Type CTs

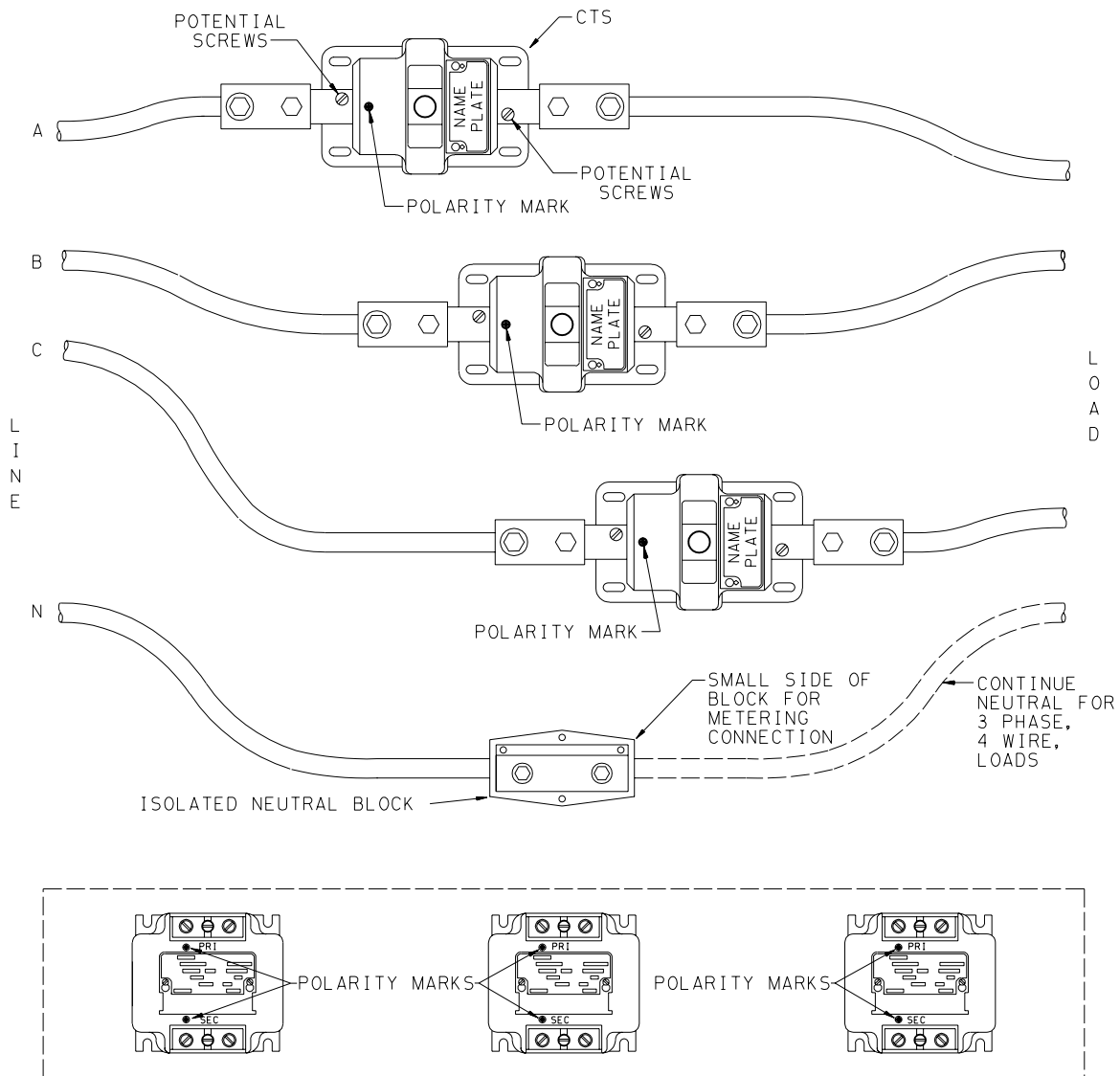

VTS NOT REQUIRED FOR 120/208Y V, 3 PHASE, 4 WIRE SUPPLY.

Notes:

1. See section [5.3.2](#).

6.15 Typical Indoor Window CT

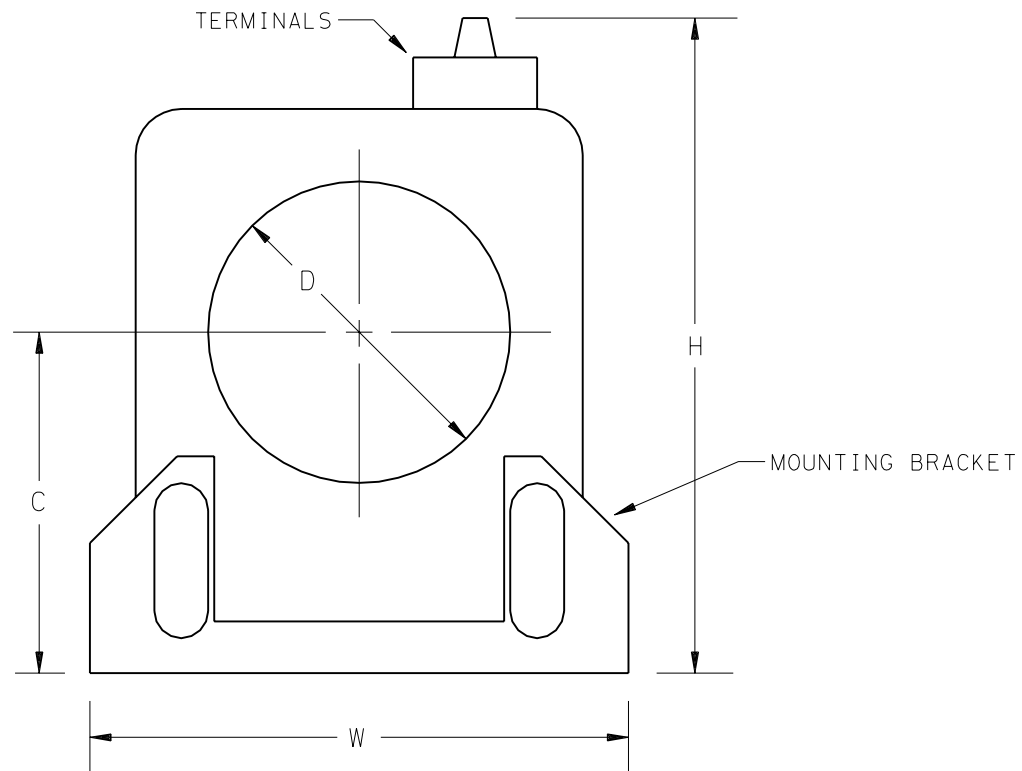

DIMENSION TABLE

Rated Current	"D" Minimum Window Diameter	"W" Maximum Body Width	"H" Maximum Overall Height	"C" Window Centre Height
1,500-5 A 2,000-5 A	146 mm (5.75")	229 mm (9.0")	292 mm (11.5")	Adjustable from 114 mm to 140 mm (4.5" to 5.5")
3,000-5 A 4,000-5 A	146 mm (5.75")	229 mm (9.0")	330 mm (13.0")	Adjustable from 146 mm to 178 mm (5.75" to 7.0")
5,000-5 A 6,000-5 A	206 mm (8.125")	292 mm (11.5")	330 mm (13.0")	145 mm \pm 3 mm (5.69" \pm 0.125")

Notes:

1. See section [5.7](#).

6.16 Typical Indoor/Outdoor Donut CT

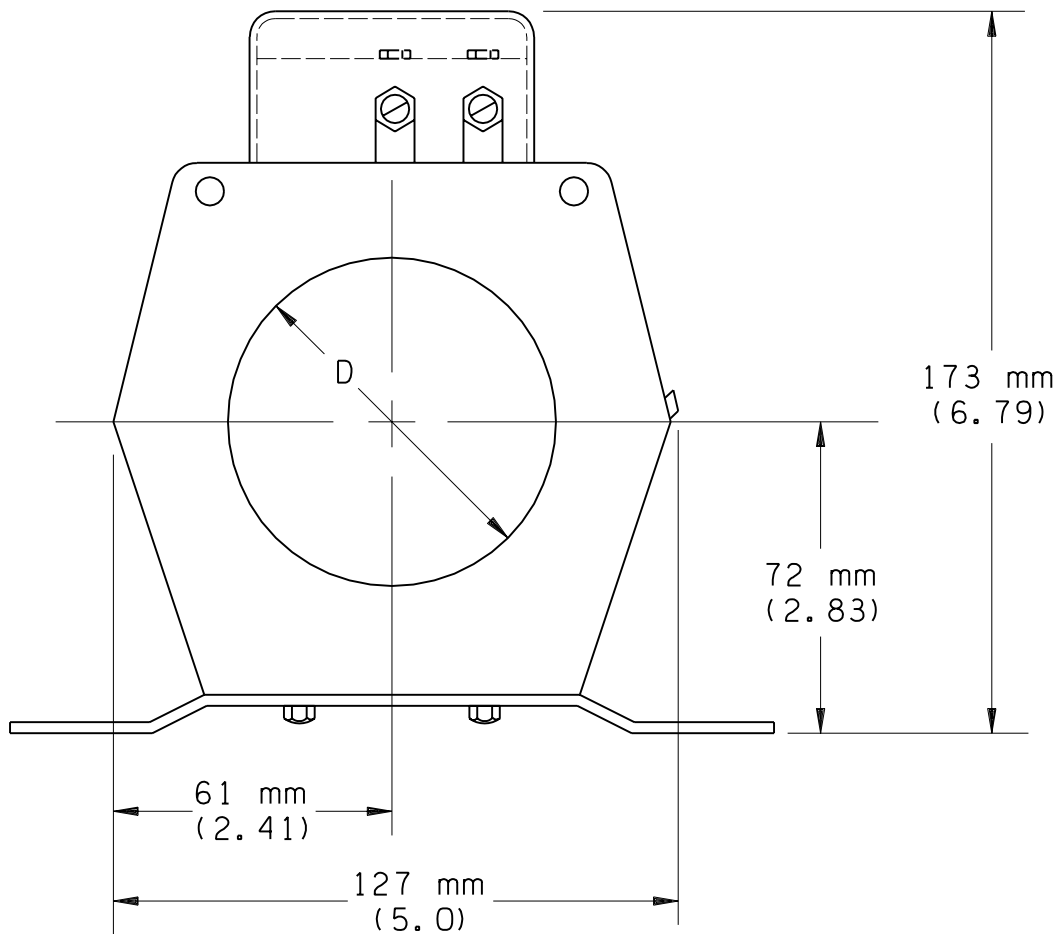

DIMENSION TABLE

Rated Current	"D" Minimum Window Diameter
200 A 300 A	63 mm (2.5")
400 A 600 A 800 A	79 mm (3.12")

Notes:

1. See section [5.7](#).

6.17 120/240 V, 1 Phase, 400 A Meter Socket Assembly, with an Integral CT

Overhead Service – Mandatory for New Services Connected after December 1, 2007

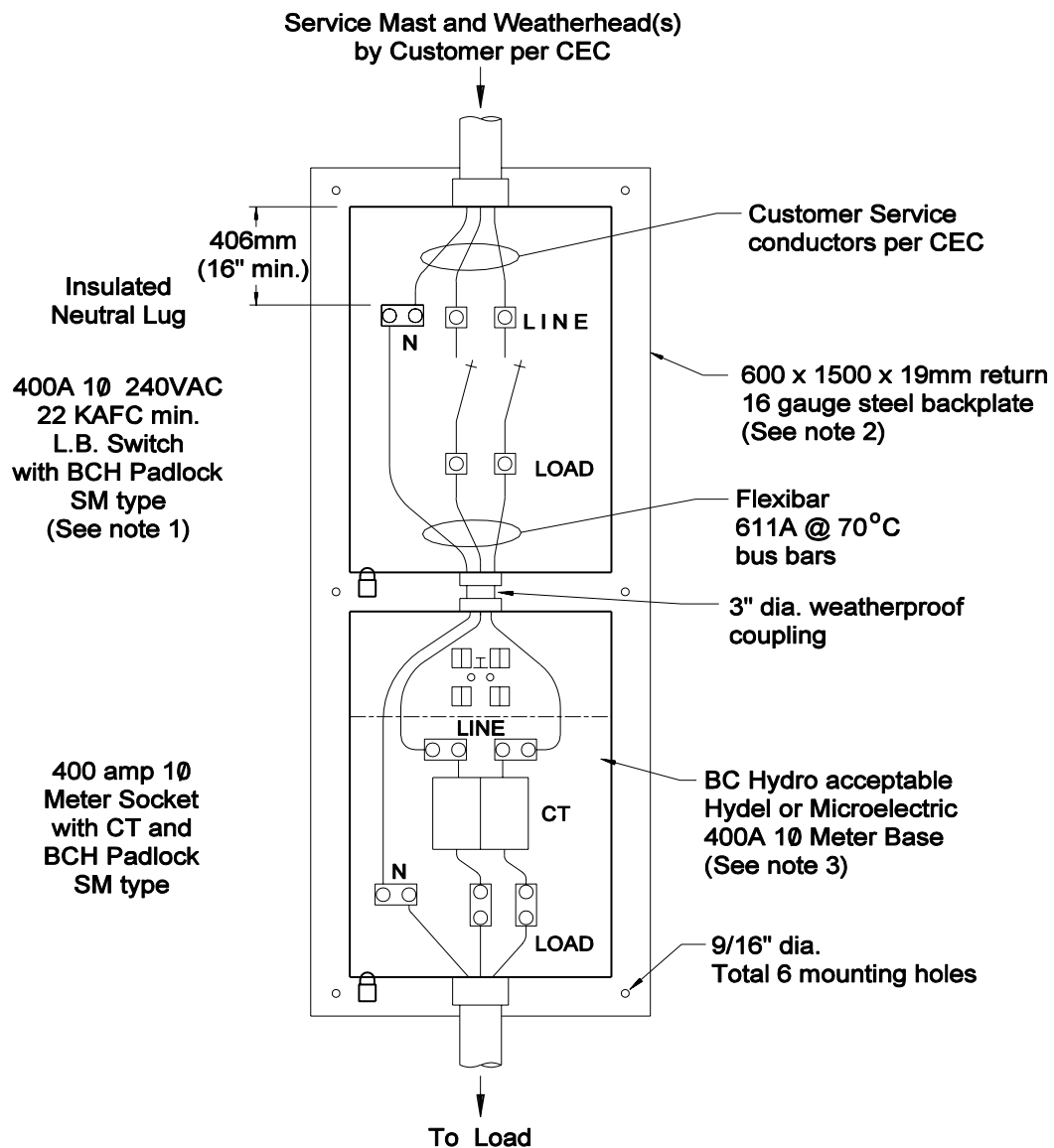

Notes:

1. BC Hydro 400A 1Ø revenue meter assembly to provide safe maintenance lockout.
2. The entire assembly shall be certified per BC Electrical Safety Regulations.
3. GESCAN Part No. BCHGT 400-0V / BCHGH 400-0V; BEAVER EL. SE401GHO / SE401GT0 are currently available certified assemblies.
4. For detailed installation refer to "BC Hydro Requirements for Secondary Metering Installations".
5. For pole mounting see ES43 G1-11.

6. See section 5.5.

Underground Service – Mandatory for New Services Connected after December 1, 2007

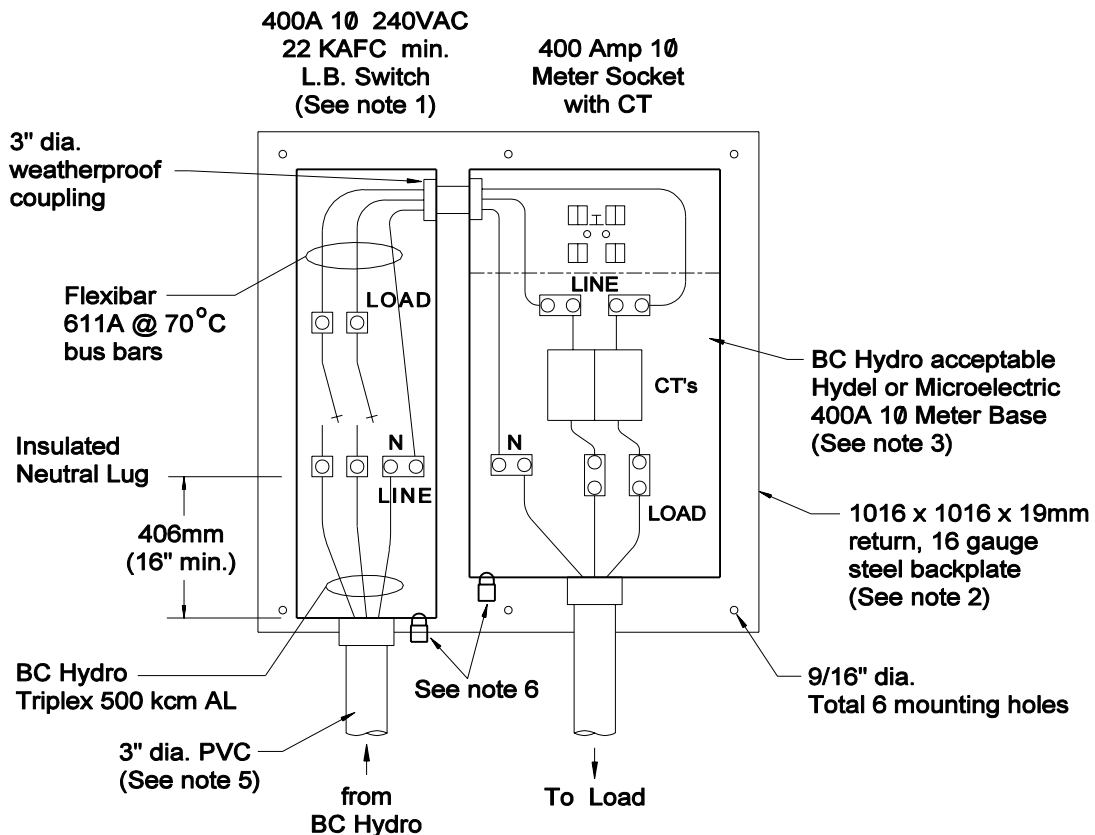

Notes:

1. BC Hydro 400A 10 revenue meter assembly to provide safe maintenance lockout.
2. The entire assembly shall be certified per BC Electrical Safety Regulations.
3. GESCAN Part No.BCHGT 400-B / BCHGH 400-B ; BEAVER EL. SE401GTB / SE401GHB are currently available assemblies.
4. For detailed installation refer to "BC Hydro Requirements for Secondary Metering Installations".
5. U/G service conduit must be installed outside foundation walls and run on surface of exterior building walls.
6. BC Hydro access only secured by SM type padlocks.
7. See section 5.5.

6.18 Outdoor Pole Mounted Transrack

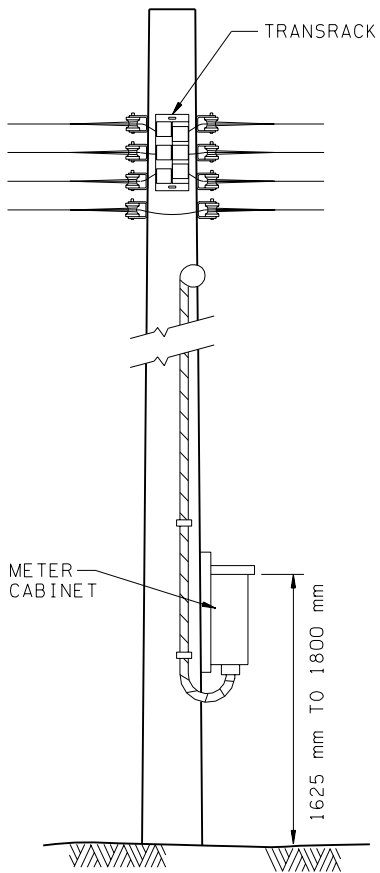

3 PHASE, 4 WIRE ILLUSTRATED

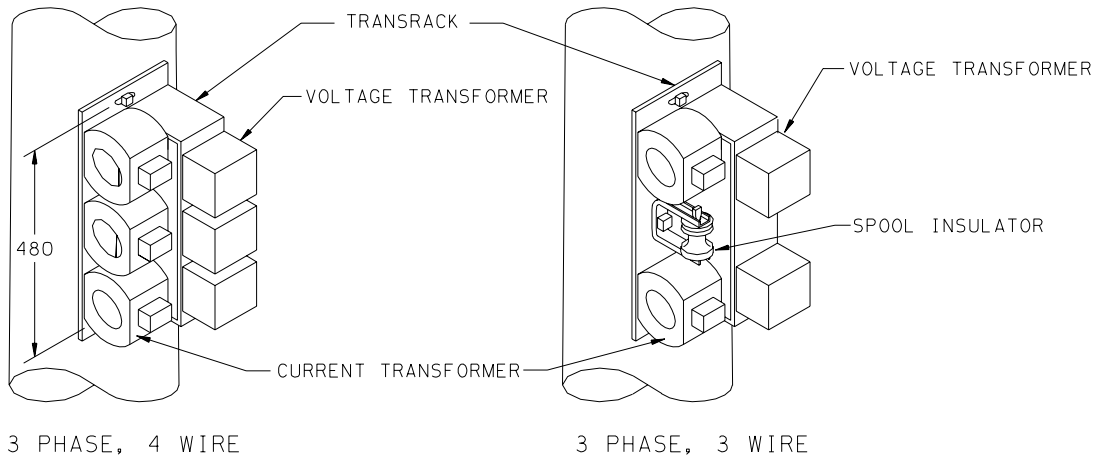

Notes:

1. See section [5.6](#).

6.19 Indoor Meter Cabinet

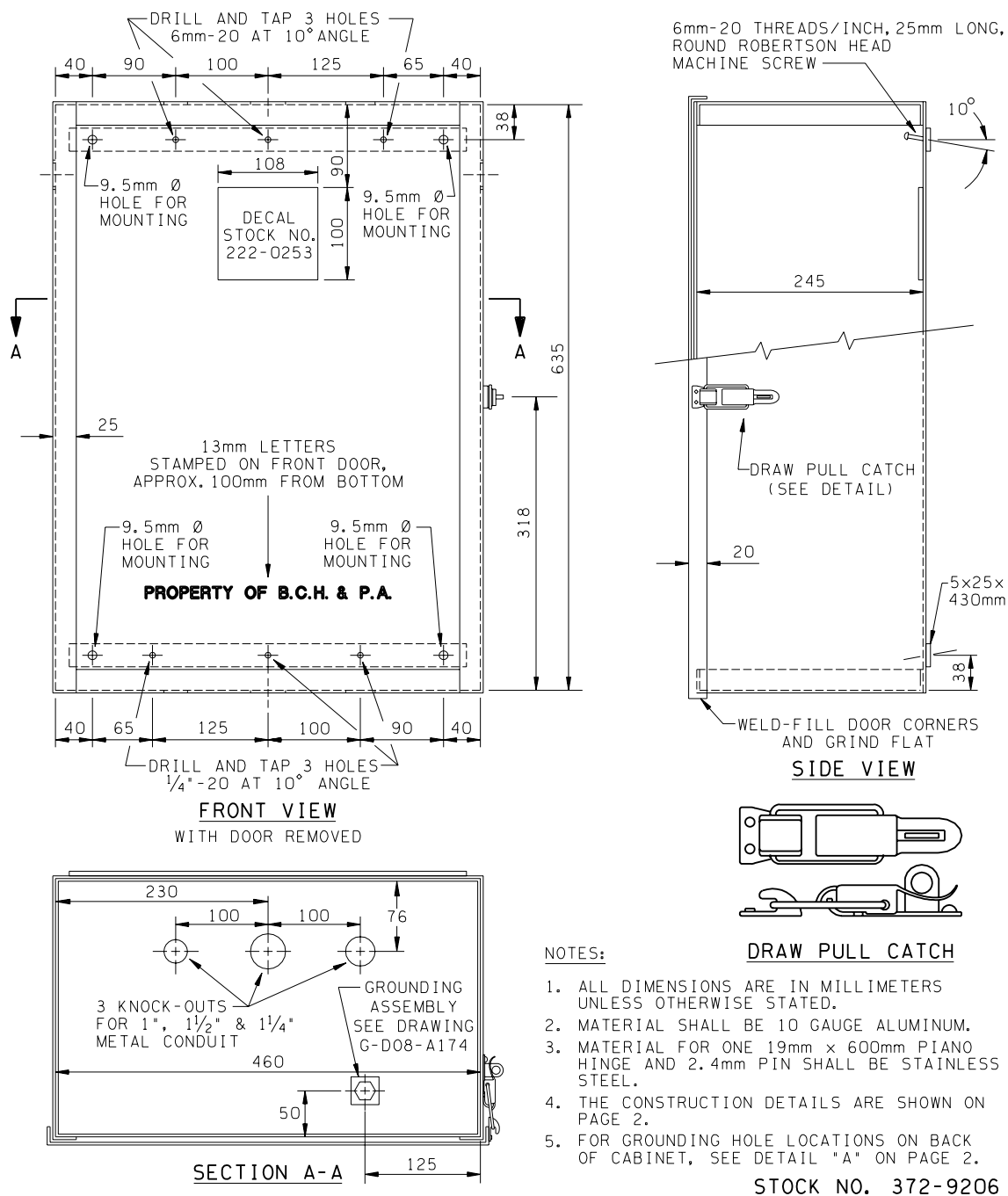

Notes:

1. See section 5.8.1.

6.20 Indoor Wall Mounted Meter Cabinet Mounting Decal

Installing instructions for indoor meter cabinet only:

BC Hydro

1. The meter cabinet shall be mounted with the door hinge on the left or the right side only. The top of the meter cabinet shall be mounted between 1630 mm (66") to 1930 mm (77") above the floor.
2. The meter cabinet shall be removable. The installation shall permit self tapping screws, installed within the meter cabinet, to project through the rear wall.

The meter cabinet shall be mounted, using all four predrilled holes, on either:

- 19 mm (3/4") plywood, using #14 – 1" wood screws; or
- Metal support channels, using 1/4" bolts.

The plywood or support channels shall be securely fastened to the wall. Shooting, or otherwise mounting the meter cabinet, directly to the wall is not permitted.

3. The conduit shall enter the meter cabinet from the bottom or from the side, within 75 mm (3") of the bottom.
4. The conduit shall be Rigid Metal, EMT or Rigid PVC. The conduit shall have not more than the equivalent of three 90° bends and shall not exceed 25 m in length.
5. The conduit minimum trade size shall be:
 - 1 1/4" (35) trade size for lengths up to 10 m;
 - 1 1/2" (41) trade size for lengths from 10 m to 25 m.

064-112 11-03

BC Hydro 

Notes:

1. See section [5.8.1](#).

6.21 Outdoor Wall Mounted Meter Cabinet

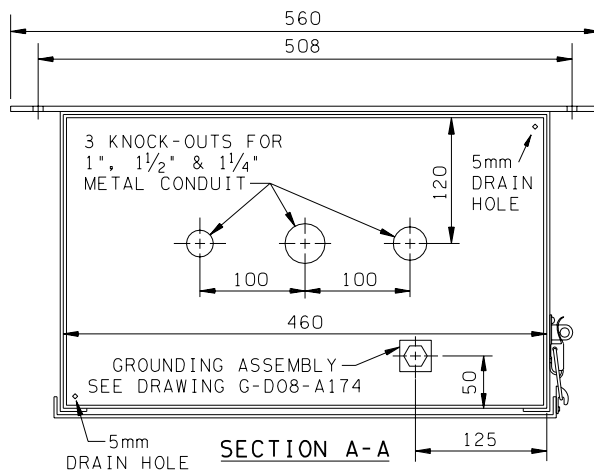
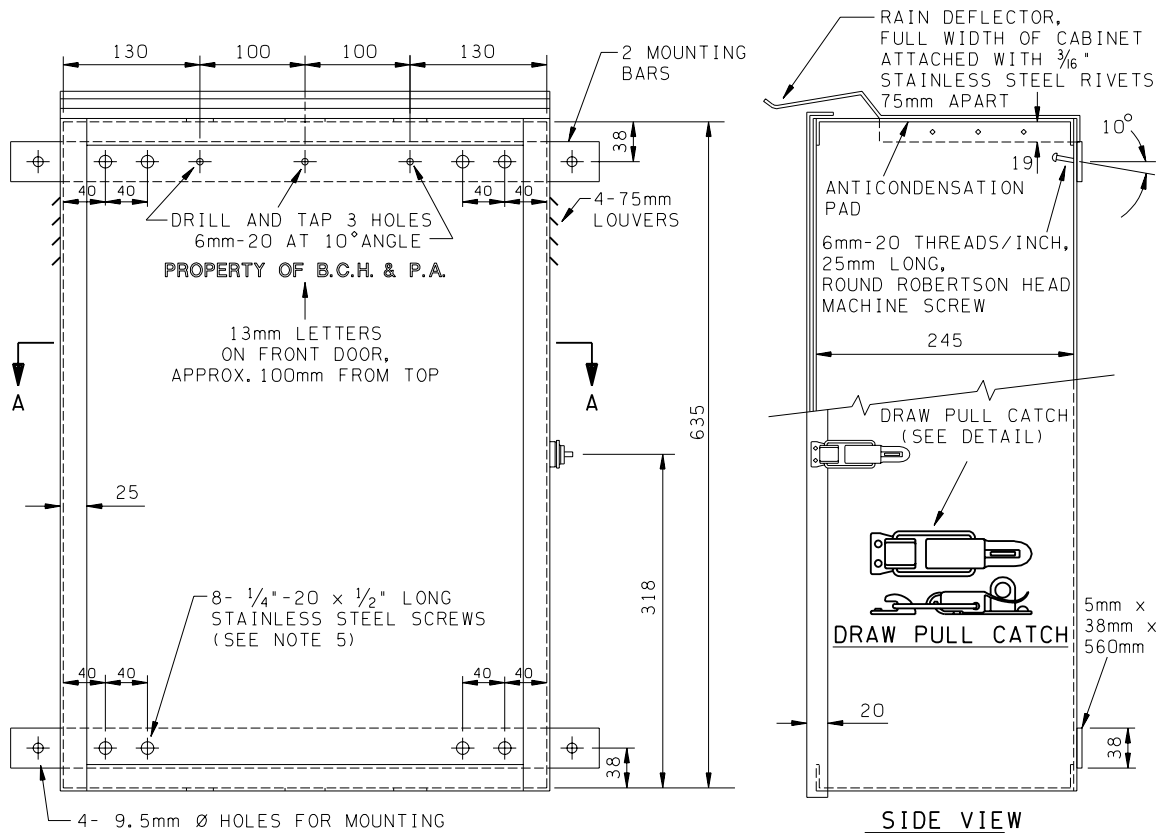

NOTES:

1. ALL DIMENSIONS ARE IN MILLIMETERS UNLESS OTHERWISE STATED.
2. MATERIAL FOR THE ENCLOSURE SHALL BE 14 GAUGE COLD ROLLED STEEL OR 14 GAUGE MAGNETIC STAINLESS STEEL, TYPE 3CR12 OR 410S.
3. MATERIAL FOR THE MOUNTING BARS AND THE ENCLOSURE SHALL BE THE SAME.
4. MATERIAL FOR ONE 19mm x 600mm PIANO HINGE AND 2.4mm PIN SHALL BE STAINLESS STEEL.
5. THE COLD ROLLED STEEL MATERIAL SHALL HAVE ASA 70 GREY POWDER COATING AS PER B. C. HYDRO SPECIFICATION 221-4000 R.0
6. WHERE COLD ROLLED MATERIAL IS USED, THE POWDER COATING SHALL BE APPLIED TO THE RAIN DEFLECTOR AND THE ENCLOSURE BEFORE ATTACHING THE TWO COMPONENTS.
7. WHERE COLD ROLLED MATERIAL IS USED, THE POWDER COATING SHALL BE APPLIED TO BOTH SIDES OF EACH MOUNTING BAR BEFORE ATTACHING TO THE CABINET WITH FOUR 1/4"-20 x 1/2" LONG ROUND HEAD STAINLESS STEEL SCREWS WITH A LOCK WASHER UNDER THE HEAD.
8. FOR FENCE MOUNTING DETAILS SEE PAGE 2.
9. FOR ALUMINUM CONSTRUCTION, THE LETTERS SHALL BE STAMPED ON DOOR.
10. FOR STAINLESS STEEL CONSTRUCTION, THE LETTERS SHALL BE SILK SCREENED IN BLACK.

STOCK NO. 372-9207

Notes:

1. See section [5.8.2](#).

6.22 Outdoor Pole Mounted Meter Cabinet

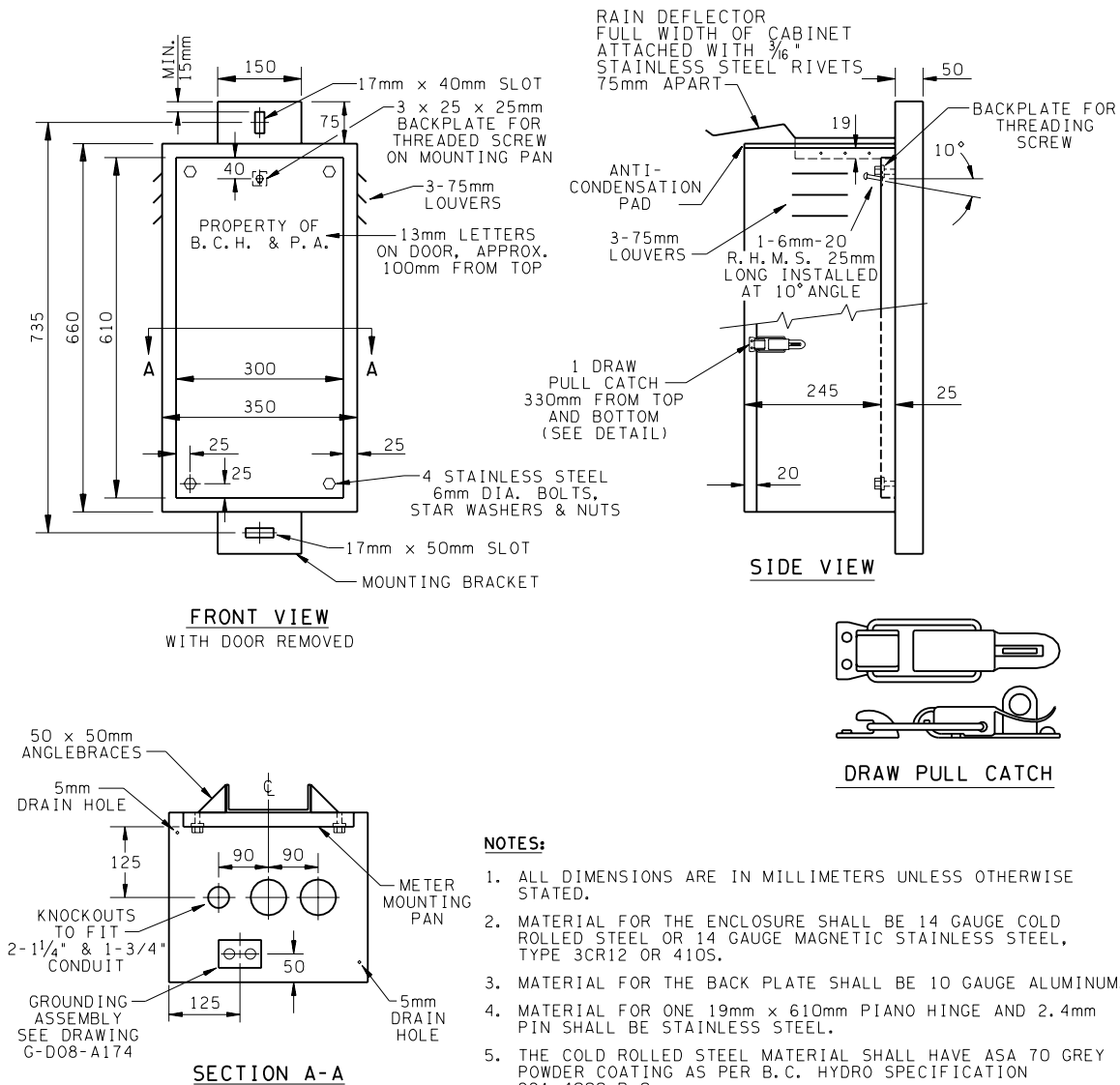

NOTES:

1. ALL DIMENSIONS ARE IN MILLIMETERS UNLESS OTHERWISE STATED.
2. MATERIAL FOR THE ENCLOSURE SHALL BE 14 GAUGE COLD ROLLED STEEL OR 14 GAUGE MAGNETIC STAINLESS STEEL, TYPE 3CR12 OR 410S.
3. MATERIAL FOR THE BACK PLATE SHALL BE 10 GAUGE ALUMINUM.
4. MATERIAL FOR ONE 19mm x 610mm PIANO HINGE AND 2.4mm PIN SHALL BE STAINLESS STEEL.
5. THE COLD ROLLED STEEL MATERIAL SHALL HAVE ASA 70 GREY POWDER COATING AS PER B. C. HYDRO SPECIFICATION 221-4000 R.0
6. WHERE COLD ROLLED MATERIAL IS USED, THE POWDER COATING SHALL BE APPLIED TO THE RAIN DEFLECTOR AND THE ENCLOSURE BEFORE ATTACHING THE TWO COMPONENTS.
7. FOR ALUMINUM CONSTRUCTION, THE LETTERS SHALL BE STAMPED ON DOOR.
8. FOR STAINLESS STEEL CONSTRUCTION, THE LETTERS SHALL BE SILK SCREENED IN BLACK.

STOCK NO. 372-9204

Notes:

1. See section 5.8.2.

To view the latest revision of this document go to:

<http://www.bchydro.com/ext/metering/>

