



**APPLICATION FOR A SPECIAL PERMIT TO OPERATE
A COMBINATION TRUCK-TRACTOR – FOUR-AXLE SEMI-TRAILER
WITH A SELF-STEERING AXLE
TO TRANSPORT DRY BULK PRODUCTS AND NC-LL PRODUCTS**
(Maximum GVW 54,000 kg – 55,500 kg)

SEND TO:

Special Permit Office
Transportation Policy Branch
New Brunswick Department of Transportation
P.O. Box 6000
Fredericton, NB E3B 5H1

FAX: (506) 444-4488
email:
special.permits@gnb.ca

Permit fee: \$50/year

Registered owner: _____

Address: _____

City _____ Prov. _____ Postal code _____

Phone no: (_____) _____ Fax: (_____) _____

TRUCK TRACTOR: (Attach list of additional trucks, including all information as marked below (►))

Make: _____ Year: _____

Full serial number: _____

Plate no: _____ Province of registration: _____

Manufacturer's rated capacity of tractor front axle: _____ kg

SEMI-TRAILER:

► Make: _____ ► Year: _____

► Full serial number: _____

► Plate no: _____ ► Province of registration: _____

Does the semi-trailer comply with all the following requirements? Yes No

- Semi-trailer axle group 5, 6 and 7 must be a tridem group utilizing a full air suspension system.
- Axle 4 must be pneumatically tied into the tridem axle group 5, 6 and 7
- For axle group 4, 5, 6, and 7, the load must be equalized between adjacent axles in the group to within 1000 kg.
- Axle 4 must be a self-steering axle
- Axle 4 may be equipped with single tires with a minimum width of 365 mm, or dual tires
- The self-steering axle may be liftable, but the controls, whether remote or manual, to raise or lower the self-steering axle must be located on the semi-trailer only, except for a semi-trailer designed to carry raw forest products where the controls can be in the cab.
- A semi-trailer may be equipped with an automatic control, which raises the self-steering axle when the vehicle is reversing.
- The tractor may have a manual controls to allow the driver to raise the self-steering axle to provide emergency drive axle traction but only if the controls do not activate unless the emergency 4-way flashers are activated and the controls must include a device which prevents the raising the axle at any speed in excess of 60 km/hr.

- The quad-axle semi-trailer must be equipped with a device that accurately displays the total weight on the semi-trailer axles in kilograms, or with a device and a table or chart from the combined use of which the total weight on the semi-trailer axles in kilograms may be readily and accurately obtained.

Truck and semi trailer combinations must comply with either diagram #1 or #2 below. Please select the diagram that matches your vehicle configurations:

(One diagram only per application)

Vehicle #1 – GVW = 55,500 kg maximum* Axle 4: single tires dual tires

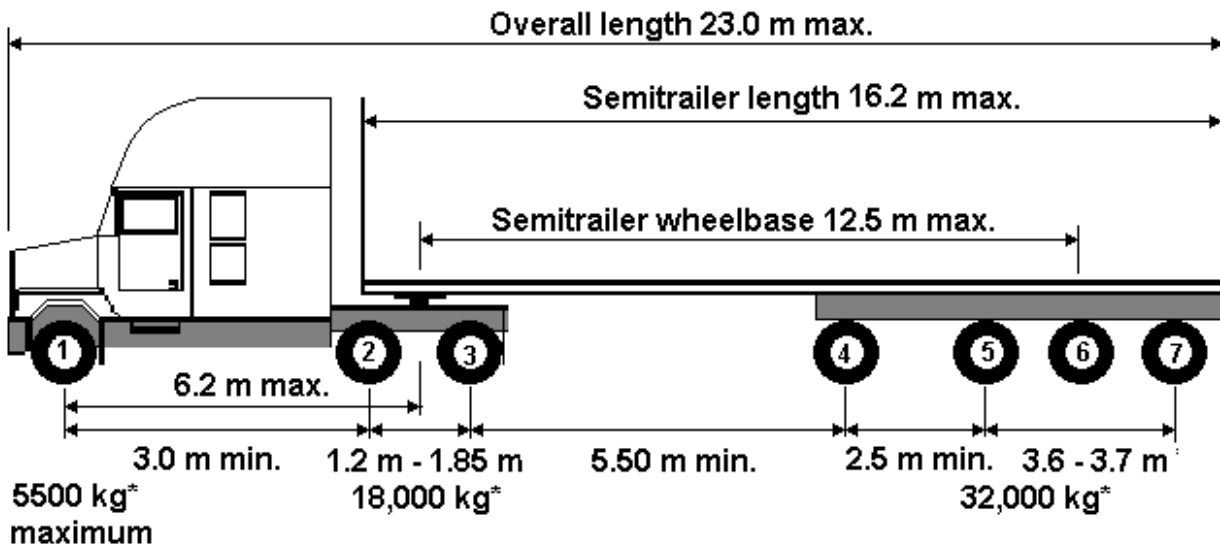

*** NOTE: No additional weight (mass) will be permitted beyond these values.**

Vehicle #2 – GVW = 54,000 kg maximum* Axle 4: single tires dual tires

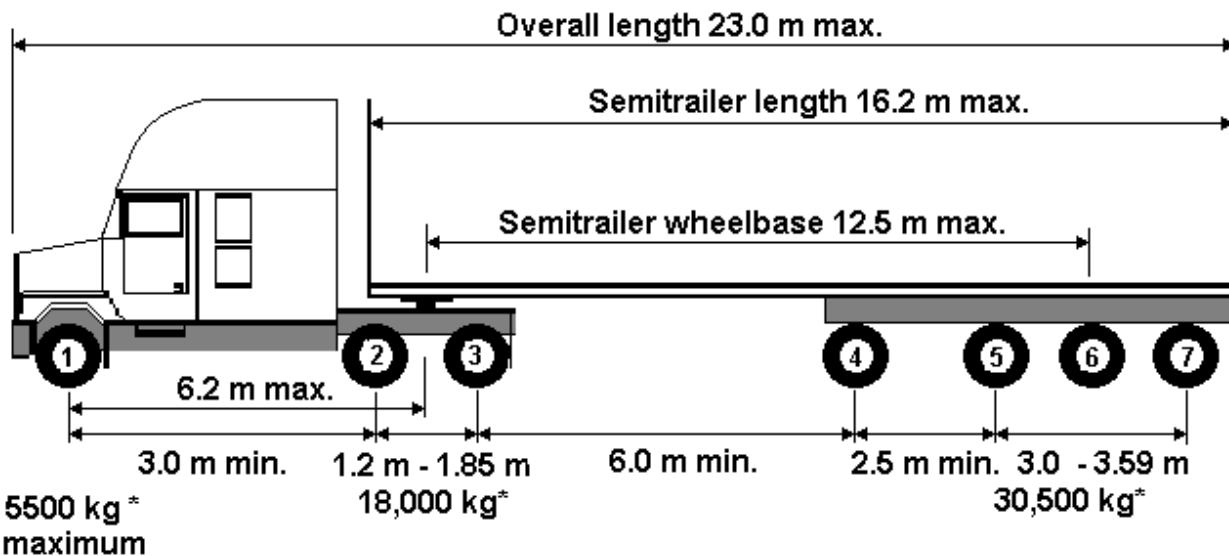

*** NOTE: No additional weight (mass) will be permitted beyond these values.**

Note: For the above diagrams #1 and #2:

- All other vehicle dimensions must comply with Regulation 2001-67
- All axles except steering axle and axle 4 must be equipped with dual tires
- All axles on trailer must utilize a full air suspension that equalizes the load between the axles to within 1000 kg
- All four axles of the semi-trailer must be deployed when trailer is loaded and operating

Dry bulk is defined as unpackaged free flowing dry solids that are loaded without being boxed, bagged or hand stowed. Examples of dry bulk include but are not limited to: sand, gravel, grain, potash, salt, sugar, aggregate, coal, grain, wood chips, cement powder, chemicals (fertilizer, plastic granules and pellets, resin powder), dry edibles (alfalfa pellets, citrus pellets, livestock feed, flour, meal, seeds, starches) and bulk mine (mineral ore, salt).

NC-LL products include round wood and logs loaded longitudinally, wood chips and hog fuel.

Vehicles must register to the gross vehicle weight authorized on the NC-DB permit for permit to be valid. Tractor must register the steer weight authorized on the NC-DB permit, if it is in excess of 5500 kg, for NC-DB permit to be valid. Registration must be in accordance with the New Brunswick Regulation 2001-67.

Payment details (do not send cash by mail):

Cash Cheque or Money order VISA Mastercard

Credit card number:

Expiry date (mm/yy):

Send permit to: Company (provide fax number if different from above)

Scale District SNB Office Location:

I hereby apply for a special permit to operate a truck-tractor and a four-axle semi-trailer, as described above, for travel in the Province of New Brunswick, transporting ONLY dry bulk products.

I understand that the permit, if it is issued, shall expire one year from the date of issue. This vehicle may be inspected during the term of said permit, to evaluate its safety and weight distribution characteristics. I further understand that an unsatisfactory carrier safety rating may be grounds for not issuing a permit, or subsequent cancellation of a permit.

I acknowledge that I have read and understood the information and requirements contained in this application and I certify that the information provided on this application is true and correct.

Name (Print): _____

Signature: _____ Date: _____