



**APPLICATION FOR A SPECIAL PERMIT TO OPERATE
A TRUCK-TRACTOR - FOUR-AXLE SEMI-TRAILER COMBINATION
TO TRANSPORT LONGITUDINALLY LOADED LOGS AND ROUNDWOOD,
WOOD CHIPS, AND FOREST BY-PRODUCTS (HOG FUEL)**

(Maximum GVW 54,000 kg – 55,500 kg)

SEND TO:

Special Permit Office
Transportation Policy Branch
New Brunswick Department of Transportation
P.O. Box 6000
Fredericton, NB E3B 5H1

FAX: (506) 444-4488
email:
special.permits@gnb.ca

Permit fee: \$50/year

Registered owner: _____

Address: _____

City _____ Prov. _____ Postal code _____

Phone no: (_____) _____ Fax: (_____) _____

TRUCK TRACTOR: (Attach list of additional trucks, including all information as marked below (►))

Make: _____ Year: _____

Full serial number: _____

Plate no: _____ Province of registration: _____

Manufacturer's rated capacity of tractor front axle: _____ kg

SEMI-TRAILER:

► Make: _____ ► Year: _____

► Full serial number: _____

► Plate no: _____ ► Province of registration: _____

Does the semi-trailer comply with the following requirements? Yes No

- The air pressure for the lift axle must not be controlled from within the cab.
- The lift axle may be fully lifted or fully lowered from within the cab.
- Semi-trailer axle group 5, 6 and 7 must be a tridem group utilizing a full air suspension system.
- Axle 4 must be pneumatically tied into the tridem axle group 5, 6 and 7
- For axle group 4, 5, 6, and 7, the load must be equalized between adjacent axles in the group to within 1000 kg.
- Only axle 4 may be a lift axle or a self-steering axle.

Vehicles must register to the gross vehicle weight authorized on the NCLL permit for permit to be valid. Tractor must register the steer weight authorized on the NCLL permit, if it is in excess of 5500 kg, for NCLL permit to be valid. Registration must be in accordance with the New Brunswick Regulation 2001-67.

Truck and semi trailer combinations must comply with either diagram #1 or #2 below.
Please select the diagram that matches your vehicle configurations:
 (One diagram only per application)

Vehicle #1 – GVW = 55,500 kg maximum*

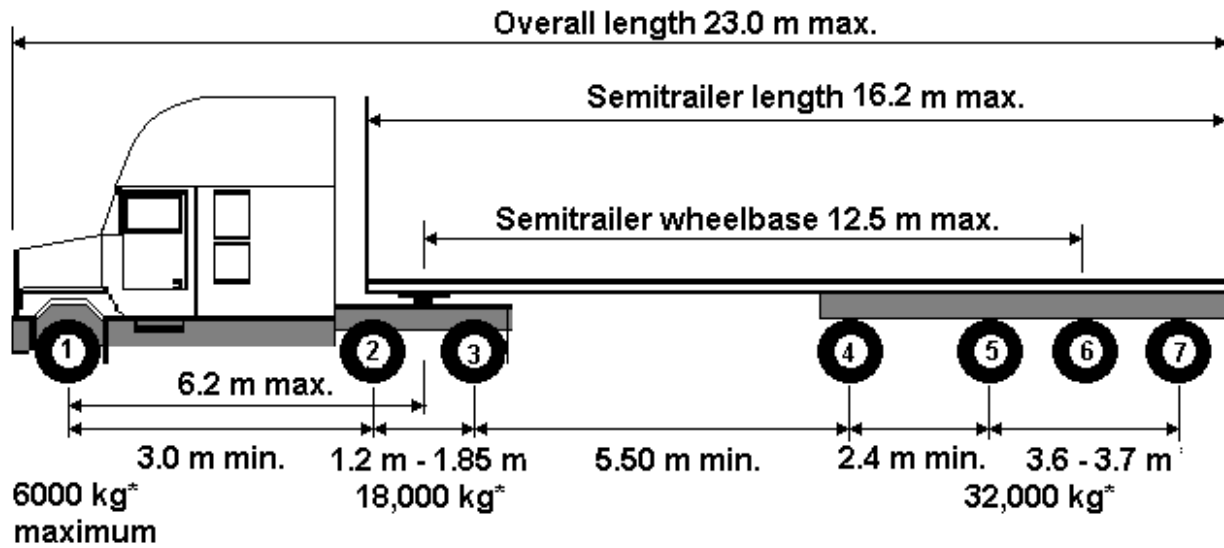

*** NOTE: No additional weight (mass) will be permitted beyond these values.**

Vehicle #2 – GVW = 54,000 kg maximum*

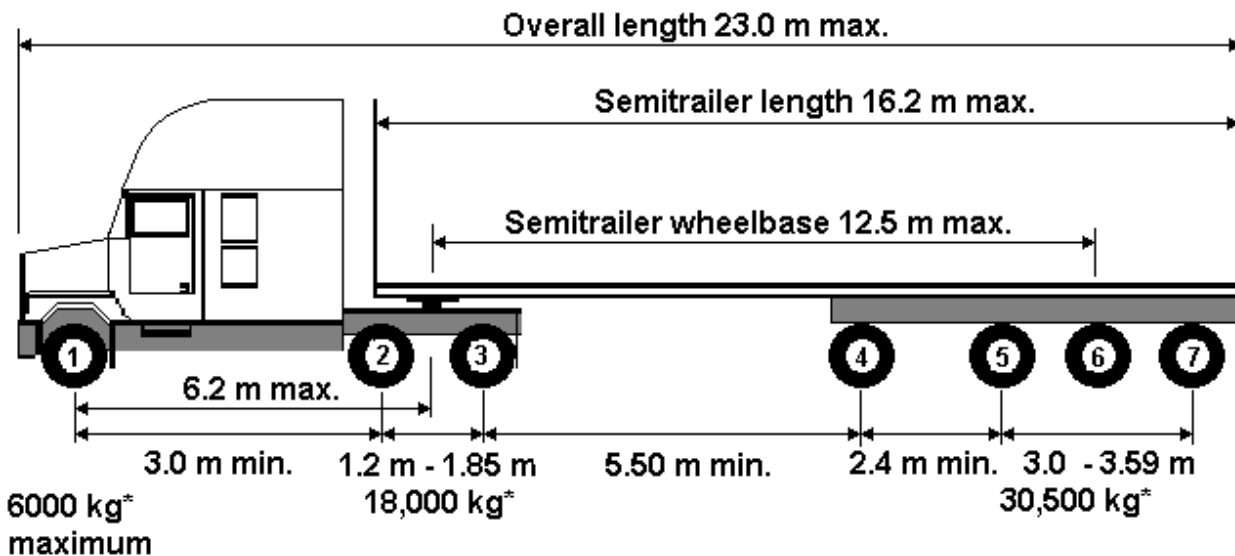

*** NOTE: No additional weight (mass) will be permitted beyond these values.**

Note: For the above diagrams #1 and #2:

- All other vehicle dimensions must comply with Regulation 2001-67
- All axles except steering axle must be equipped with dual tires
- All axles on trailer must utilize a full air suspension that equalizes the load between the axles to within 1000 kg
- All four axles of the semi-trailer must be deployed when trailer is loaded and operating

Payment details (do not send cash by mail):	
Cash <input type="checkbox"/> Cheque or Money order <input type="checkbox"/> VISA <input type="checkbox"/> Mastercard <input type="checkbox"/>	
Credit card number:	Expiry date (mm/yy):

Send permit to: Company (provide fax number if different from above) <input type="checkbox"/>
Scale <input type="checkbox"/> District <input type="checkbox"/> SNB Office <input type="checkbox"/> Location:

I hereby apply for a special permit to operate a truck-tractor and a four-axle semi-trailer, as described above, for travel in the Province of New Brunswick, transporting ONLY longitudinally loaded logs and roundwood, and wood chips.

I understand that the permit, if it is issued, shall expire one year from the date of issue. This vehicle may be inspected during the term of said permit, to evaluate its safety and weight distribution characteristics. I further understand that an unsatisfactory carrier safety rating may be grounds for not issuing a permit, or subsequent cancellation of a permit.

I acknowledge that I have read and understood the information and requirements contained in this application and I certify that the information provided on this application is true and correct.

Name (Print): _____

Signature: _____ Date: _____