



CANADIAN FORCES - DEPUTY RETURNING OFFICERS BRIEFING

**2011 FEDERAL
GENERAL ELECTION
(Military Vote: 18 Apr 2011 to 23 Apr 2011)**

DRO Lecturers and Legal Advisers

‣ LCol R. Strum, ADJAG/MJ&AL

‣ Maj M. Côté, DLaw/MJP&R

‣ Maj K.A. Reichert, DLaw/Mil Pers

‣ Mrs. S. Touchette, DLaw/CBP&E (E&E)

LECTURE OUTLINE

I – Introduction

Overview

Election officials: Role and Responsibilities

II – Duties

Commanding Officers

Liaison Officers - General duties

Deputy Returning Officers

III - Service voting procedure

Qualifications and entitlements to vote

Statement of ordinary residence

Method to take the service vote

Procedure for casting vote

Calendar - Crucial dates for Liaison Officers/Deputy Returning Officers

Financial administration

Political activities by Canadian Forces members – Restrictions

Questions

Contacts - Numbers and addresses

INTRODUCTION

1. Your CO has appointed you to establish the polling station and take the vote of CF electors.
2. You must know the procedures for CF voting.
3. You must be impartial in performing your duties, and answer questions related to the electoral process only.

OVERVIEW

Canadian Forces (CF) electors vote at federal general elections in one of two ways:

- a) under the Special Voting Rules (SVRs) - at a service polling station for a candidate running in the electoral district encompassing the selected place of ordinary residence reflected on the elector's Statement of Ordinary Residence (SOR); or
- b) if a elector has not voted under the SVRs - at a civilian polling station but only if it is in the electoral district shown on his/her SOR and he/she ordinarily resides in that electoral district as of polling day.

KEY PLAYERS

Chief Electoral Officer (CEO)

**Special Voting Rules Administrator (SVRA) and
the Military Vote Coordinator (MVC)**

Coordinating Officer (Coord O)

Liaison Officers (LOs)

Commanding Officers (COs)

Deputy Returning Officers (DROs)

Admin/Fin Clerks (RMS)

CHIEF ELECTORAL OFFICER

Incumbent: Mr. Marc Mayrand

The Chief Electoral Officer (CEO)

- supervises the conduct of elections
- ensures that all election officers act with fairness and impartiality
- issues administrative instructions
- implement public education and information programs

(ss.16 &18 CEA)

SPECIAL VOTING RULES

ADMINISTRATOR (SVRA) – ELECTIONS

CANADA

Incumbent: Ms. Lyne Morin, at Elections Canada (EC)

Assistant – Military Vote Coordinator – Michel Lefebvre, at Elections Canada

The SVRA

1. obtains from the LOs the list of names of electors from each CF unit
2. obtains from the LOs the list of names of DROs that is provided by COs
3. distributes the election materials and the list of candidates
4. receives, validates, and sorts the ballots marked by CF electors
5. proceeds with the counting of the votes of electors on civilian polling day in Ottawa (2 May 11), and
6. communicates the results of the votes cast.

(ss.181-182 CEA)

DND COORDINATING PERSONNEL - MANDATE

DND Coordinating Officer (DND Coord Offr): **Col V. Joshi**

DND Deputy Coordinating Officer (DND Deputy Coord Offr): **LCol R. Strum**

Elections Administration Officer (Elections Adm Offr): **Ms. Suzanne Touchette**

Assistant to the Elections Admin Officer (Elections Coord): **Mrs. Natalie Payant**

- The Minister of National Defence (MND) appointed the DND Coord Offr to work both during and between elections with the CEO.
- the DND Coord Offr informs service members, through a CANELECTGEN, of the terms and conditions of voting.

LIAISON OFFICERS AND SUPPORT STAFF

- LOs are appointed by the Minister
- LOs and support staff cooperate with the CEO and Coord Offr in the administration of the vote of CF electors
- LOs liaise between COs and DROs and with SVRA
- The main functions of LOs are to ensure that every CF elector receives information concerning the voting procedures, that they are given the opportunity to vote, and that the completed ballots are properly transported back to the SVRA in Ottawa.
ON TIME (2 May 11, by 18h00).

*** IF YOU HAVE ANY QUESTIONS ABOUT THE SPECIAL VOTING RULES (SVR) AND PROCEDURES, OR IF YOU ENCOUNTER DIFFICULTIES – CONTACT YOUR LO.**

COMMANDING OFFICERS

(Statutory duties of Commanding Officers)

Within seven days after writs are issued, the CO

1. Publish a notice of election in unit orders and post it prominently.
2. Prepare an alphabetical list of all CF electors serving in or attached to the CO's unit, based on the SORs held in unit records (s.205(1)(b) CEA).
3. Establish polling stations, including joint polling stations or mobile polls as needed; notify the appropriate LO of the number and location of polling stations, and arrangements for mobile polls.
4. Designate DROs for each station.
5. Provide a list of the names/ranks of DROs and electors to CEO/SVRA.
6. Provide the facilities and resources for the vote.
7. Fix voting dates and times.
8. Publish a notice of voting dates/times and places.

(ss.204-209 CEA)

COMMANDING OFFICERS

(Statutory duties of Commanding Officers)

Upon receipt of elections materials

- Acknowledge receipt
- Distribute materials to DROs in sufficient quantities

Additional Responsibilities

1. Post lists of candidates in conspicuous places
2. Provide special mailing facilities/support
3. With LO, arrange transportation of ballots and materials
4. Protect secrecy of the ballots
5. Send the ballots to the SVRA in Ottawa, by **priority post** or other service means as often as possible

(ss.204-209 CEA)

DUTIES OF DEPUTY RETURNING OFFICERS

- Attend DRO briefing session – to ensure performance of duties is in accordance with the **Canadian Elections Act**
- Be familiar with *DRO Manual* (Voting by CF electors) (EC 78130 (10/04) – (N.B. This publication is available on the JAG WEBSITE)
- Be familiar with *The Guide to Federal Electoral Districts* and *Street Indexes*
- Establish telephone/FAX communication directly with your Liaison Officer a.s.a.p. (communicate with, inform and seek advice from your LO)
- Receive all election material, ensure quantities are sufficient, count ballot papers and return by fax and mail the white copy of the supply distribution record (FORM EC 78190) to SVRA
- control voting materials until returned to CO
- Assign personnel for mobile polling stations (one DRO for mobile polling stations is sufficient). Many Reserve Force units have full-time members
- Know and comply with the dates and times during which polling stations must be opened (consult notice of election issued by the unit's CO)

DUTIES OF DEPUTY RETURNING OFFICERS

- Set up polling station to ensure the elector can vote in secrecy
- Ensure that you will have a **phone** at your polling station and an **assistant** to help you deal with list of CF electors and admin duties.
- personally supervise the operations in the polling station
- personally take the vote of all CF electors

(N.B. This task is not to be left to your assistant)

- execute SORs where necessary for Res F members
- Keep available for consultation: one set of street indexes, one guide to electoral districts, one list of candidates, and one list of electors
- Ensure that voting instructions card for Canadian Forces Electors (Form EC78120 (01/02)) are put in conspicuous places
- protect secrecy of vote and maintain decorum at the polling station
- Grant access to voting area to authorized representatives of political parties. The representative should have an authorization form signed by the political candidate (form EC 78070)

(ss.212, 213 & 267 CEA)

DUTIES OF DEPUTY RETURNING OFFICERS

- Ensure every eligible voter has the opportunity to vote, including:
 - incarcerated members
 - incapacitated members (physical disability, hospitalized members)
 - members on TD or leave in your area

DUTIES OF DEPUTY RETURNING OFFICERS

- IMPORTANT – Outer envelope - Ensure the outer envelope:
 - is personally signed and dated by the elector
 - reflects the elector's name and service number
 - reflects the correct electoral district of the CF elector and applicable code
 - the elector's unit name
- MOST CRITICAL - ensure that all completed ballots reach the **SVRA NO LATER THAN 1800 hrs** on civilian polling day (2 May 11) - send ballots by **priority post**, courier or CF means of transportation as often as practicable
- NOTE: Do not include unused/spoiled ballots or other voting material with the completed ballots marked by CF electors.

DUTIES OF DEPUTY RETURNING OFFICER AFTER VOTING IS COMPLETED

- By 29 Apr 11 - send your after action report to LO through Sr DRO
- By 12 May 11 - return all unused material including ballot stubs, and spoiled ballots to the SVRA (N.B. not with completed ballots)
- By 6 Jun 11 - DROs and LOs - send detailed expense report to Ottawa Elections HQ Fin Clerk (**MCpl Michel Pelletier**) (through Sr LO of voting area)
- Send your after action report to your local LO, through your Sr DRO, detailing relevant information concerning the taking of the vote
- **Do Not send SORs completed at the polling station by Reserve Force members to the SVRA/CEO (Elections Canada) for validation. These SORs are to be retained in Unit file**

(ss.210-219 CEA)

Voting by CF electors – 2 brochures to understand the process

- ▶ 1. It is simple, secret and it counts (EC 78003 (02/11)):
explain when and where to vote, how the vote works, counting the ballots
- ▶ 2. Message to CF electors (EC 78001 (01/02)): relates to Statement of Ordinary Residence (SOR)
- ▶ (Note: Brochures EC 78003 (02/2011) and EC 78001 (01/02) were distributed in large numbers in your region)

SERVICE VOTING PERIOD

➤ Service voting must occur during the period of the 14th and 9th day before civilian polling day (i.e. 18 Apr to 23 Apr 11 inclusively). A CO must determine when, during that period, polls will be open.

➤ **Minimum** requirements:

At least 3 days and at least 3 hours per day (ss.205(3) and 208 CEA).

➤ Where necessary, polls could be opened:

- after hours
- Saturdays

Note: Only by exceptions and only if approved by the CEO at EC, the service voting period in respect of specific electors can be held outside the service voting period. The request is made by the Liaison Officer to the DND/CF Coord SVR.

NOTICES OF ELECTION

- **First Notice**: When writs have been issued each CO shall publish, as part of unit orders, a notice informing electors:
 - that an election has been called;
 - of the polling date;
 - that CF electors may vote under SVRs;
 - that he will designate DROs; and
 - that he will fix the voting times during the voting period
- (s.204 CEA)

Second Notice: Starting 3 days prior and each day during the period 18 to 23 April 2011 inclusively, the CO must publish, in his or her unit's orders and post in a conspicuous place, a notice that states:

- the days on which the electors may vote;
- the precise location of, and the voting hours at, each polling station, other than a mobile polling station; and
- in the case of a mobile polling station, its location and the anticipated period during which it is to remain at that location.

(s.208 CEA)

CF ELECTOR - QUALIFICATIONS AND ENTITLEMENT TO VOTE

- Canadian Citizen
- 18 years of age or over on civilian polling day
- Member of the Regular Force
- Member of the Reserve Force on full-time training or service, or on active service (Class B or C - any time from **26 Mar 11** to **30 Apr 11** inclusive)
- Civilian elector who is employed outside Canada by the CF as a teacher in, or as a member of the administrative support staff for a CF school

STATEMENT OF ORDINARY RESIDENCE

- Members of Regular Force (DND 406):
 - must complete on enrolment - subsequent amendment is discretionary (Note to DRO: In June 2010, Elections Canada sent a letter to all CF electors providing the opportunity to verify or amend their SOR)
- Members of Reserve Force on full-time training or service (DND 407):
 - must complete where on full-time training or service **between date of issue of writs and the Saturday preceding civilian polling day** N.B.: on full-time training or service means CF members on Class B or C Reserve Service
- Members of Reserve Force on Active Service
 - must complete when placed on active service
 - N.B.: Reserve Force members are considered on active service anywhere beyond Canada (OIC P.C. 1989-583 of 6 Apr 89)

STATEMENT OF ORDINARY RESIDENCE

The SOR indicates:

- the person's surname, given names, sex and rank;
- the person's date of birth;
- the civic address of the person's place of ordinary residence in Canada immediately before enrolment, transfer or hiring; and
- the person's current mailing address.

(ss.194-195 CEA)

AMENDMENTS TO STATEMENT OF ORDINARY RESIDENCE

- Members of Regular Force may amend their SOR at any time
- The amendment comes into effect 60 days after its reception by the CO of the unit responsible for the records (URS), except when made during an election period
- If made during an election period, the amendment comes into effect 14 days after civilian polling day
- **N.B.: In June 2010, Elections Canada sent a letter to all CF electors providing the opportunity to verify or amend their SOR information.**

(CANFORGEN 160/07, DJAGMJAL 021418Z NOV 07 was also distributed to CF electors in Nov 2007, informing them of the procedure to be followed, should they wish to amend their SOR)

PLACE OF ORDINARY RESIDENCE

- ▶ A CF elector's ordinary residence is one of the following locations:
 - the place of ordinary residence of the spouse, the common-law partner, a relative or a dependant of the eligible elector, a relative of his or her spouse or common-law partner or a person with whom the elector would live but for his or her being enrolled in or hired by the CF;
 - the place where the member is residing by reason of his or her performance of services as a member of the CF; or
 - the elector's place of his or her ordinary residence immediately before being enrolled in or hired by the CF.

VOTING AT A CIVILIAN POLLING STATION

Voting at a civilian polling station is authorized only if:

- a. the elector completed a SOR;
- b. the elector actually resides in the electoral district that the elector has named in his or her SOR;
- c. (1) the elector's name is included on the national Register of electors, or
(2) the elector provides satisfactory proof of identity and residence, or
(3) the elector takes the prescribed oath and is accompanied by an elector whose name appears on the list of electors for the same polling division and who vouches for him or her on oath in the prescribed form; and (s.161 CEA)
- d. the elector has not voted under the SVR at a service polling station.

METHODS TO TAKE THE SERVICE VOTE

Fixed polling station: polling station established at the unit

Joint polling stations: if two or more units are in the same locality and it would be expedient that CF electors cast their ballots before one DRO

Mobile poll: if elector cannot conveniently reach the polling stations established at the elector's unit

Individual DRO: may be appropriate for remote locations and where few CF members are located

MEMBERS IN HOSPITAL

If DRO designated to take the vote of members in hospital and officer in charge of hospital approves, designated DRO may go from room to room.

If DRO is not designated to take the vote of members in hospital, the DRO appointed for the unit to which the hospital belongs may take the ballot of electors.

(s.217(2) (3) CEA)

CF ELECTOR FROM ANOTHER UNIT

(Temporary Duty or Leave)

- CF elector on TD or leave may vote at any service polling station if the elector has proof that he is a qualified CF elector.
- COs should ensure that leave forms or travel claims have a notation showing the electoral district of the CF elector.
- Each LO will be provided with an alphabetical list of all CF electors and will be able to confirm, on request from a DRO, the name of the member's electoral district.

CF ELECTOR FROM ANOTHER UNIT

(Temporary Duty or Leave)

The name of an elector from another unit will not be recorded on your unit list of CF electors. To ascertain the electoral district:

1. Check member's documentation (i.e. annotated travel claims or leave form):

- a) check Guide to Federal Electoral Districts and Street Indexes
- b) if in doubt, call your LO to obtain the member's electoral district from the CF Alphabetical List (Reg Force)

2. Where a CF elector has no documentation or does not know his/her address and/or city as recorded on SOR:

- a) call your LO to obtain the member's electoral district from the Alpha list; or
- b) call the member's unit to check unit record for SOR and the member's electoral district

INCARCERATED ELECTOR

A incarcerated CF elector is entitled to vote

At a service polling station if elector is in a detention barrack or service prison; or
(this includes accused in pre-trial custody)

Before a DRO, if elector is in a civil correctional institution. Check with incarcerated CF elector to determine if he or she wants to vote.

(s.245, CEA)

LIST OF CANDIDATES FOR THE 308 ELECTORAL DISTRICTS

This list of candidates for each of the 308 electoral districts will be issued by CANELECTGEN message on or about **14 Apr 11**.

N.B. The list of candidates for the 2011 election will also be posted on the JAG Website.

How to determine your CF elector's electoral district:

You can consult the Elections Canada Website, and on the front page enter the appropriate member's postal code for the address of the member's SOR, which should relate to your assigned electoral district; or

Use *Street Indexes* or *Guide to Federal Electoral Districts*

PREPARATION FOR VOTING

- 1 - Have the list of CF electors prepared by the unit, provided by CO (not ADM(HR Mil)/DHRIM list)
- 2 - Obtain adequate voting material and other required supplies from LOs/SVRA, including sufficient quantities of postage stamps. You can use the “**Unit Requirement of Election Material**” form to order supplies.
- 3 - Check the voting material, count ballot papers and return, via FAX the white copy of the supply distribution record (EC 78190 or Ref 78190) to SVRA in Ottawa
- 4 - Keep ballots in secure place
- 5 - Properly set up polling station to enable electors to vote in secret and **ensure that EC large posters are affixed at the right locations (so that electors know where to vote)**
- 6 - Know the dates and time of your polling station - notice of election issued by CO - ensure notice has been posted and published in routine orders
- 7 - Receive list of candidates and political parties - draw a heavy line above and below the list of candidates for each electoral district
- 8 - Instructions Cards (at least two) (EC 78120) to be posted conspicuously in the polling station

UNIT REQUIREMENT OF ELECTION MATERIAL
REQUISITION DU MATÉRIEL D'ÉLECTION POUR LES UNITÉS

FROM/DE: LO/OL _____

TO/À: SVR – Military Vote Coordinator/RÉS - Coordonnateur - Vote militaire

The units listed hereunder will require material for the number of electors and Deputy Returning Officers as indicated/les unité figurant plus bas ont besoin du matériel pour le nombre d'électeurs et les scrutateurs tel qu'indiqué:

UNIT(S) AND SHIPPING ADDRESS/UNITÉ ET ADRESSE D'ENVOI:

NAME OF CONTACT PERSON (Sr DRO/DRO) AND TELEPHONE NUMBER/
NOM DE LA PERSONNE RESSOURCE (SCRUTATEUR SUPÉRIEUR/
SCRUTATEUR ET NUMÉRO DE TÉLÉPHONE

NUMBER OF ELECTORS/NOMBRE D'ÉLECTEURS :

NUMBER OF RESERVISTS ON CLASS C/B :

NUMBER OF DROs/NOMBRE DE SCRUTATEURS

NUMBER OF POLLING STATIONS/NOMBRE DE BUREAUX DE SCRUTIN :

NOTE: Shipping address must be an actual building, street number where materials can be delivered by courier. Postal boxes, CFPOs, FMOs are not acceptable/L'adresse d'envoi doit être actuellement un édifice, numéro de rue etc où le matériel peut être livré par messagerie. Les casiers postaux des Forces canadiennes et américaines sont inacceptables.

**(forward by hand or by fax to/faire parvenir en personne ou par télécopieur au :
613-991-4366 or 1-888-770-2062)**

Contact information if you have questions/Les contacts à Élections Canada si vous avez des questions supplémentaires

Michel Lefebvre (613) 949-3100 cell : (613) 808-7901
Miville Roy (613) 991-4470 cell : (613) 298-1568

2011-04-08

Unit requirement of Election Material Form

PREPARATION FOR VOTING (Cont'd)

9 - Ensure that each CF elector will have access to:

- Special Voting Rules (SVR) - Part 11 of the Canada Elections Act
- Guide to Federal Electoral Districts (EC06508)
- Street indexes
- List of the names of candidates
- Instructions Cards (EC78120) (s.210(1)(b) CEA)

10 - Ensure there is a pen or sharpened pencil available to mark the ballot

11 – Obtain postage stamps in sufficient quantity: (for CF electors who wish to mail their ballot themselves)

12 - Prepare and check the polling station before opening time

13 - If a representative of a political party is present, ensure that you receive a properly signed appointment form (EC78070). Make a copy of the form and annotate time period representative remains on premises. Retain the original form while representative is at the polling station and return original to representative upon his/her departure from premises

Authorisation of a political party representative

(EC 78070)



EC 78070
(03/00)

AUTHORIZATION OF A POLITICAL PARTY REPRESENTATIVE

AUTORISATION D'UN REPRÉSENTANT D'UN PARTI POLITIQUE

TYPE OR PRINT IN BLOCK LETTERS / DACTYLOGRAPHIER OU ÉCRIRE EN LETTRES MOULÉES

NAME / NOM	POLITICAL PARTY / PARTI POLITIQUE
POLLING STATION / BUREAU DU SCRUTIN	

I hereby authorize the above-named person to act as a representative of my political party at this polling station set up for voting by Canadian Forces electors for the current federal election.

J'autorise par la présente la personne mentionnée plus haut à agir comme représentant(e) de mon parti politique à ce bureau de scrutin établi pour la tenue du vote des électeurs des Forces canadiennes, à l'élection fédérale en cours.

CANDIDATE'S SIGNATURE / SIGNATURE DU CANDIDAT

DATE

THIS AUTHORIZATION MUST BE DELIVERED TO AND
RETAINED BY THE DEPUTY RETURNING OFFICER

CETTE AUTORISATION DOIT ÊTRE REMISE AU
SCRUTATEUR QUI DOIT LA CONSERVER

OATH OF REPRESENTATIVE

I, the undersigned, authorized to be in attendance at this polling station, swear or solemnly affirm that:

- I will maintain and aid in maintaining the secrecy of the vote;
- I will not interfere with the marking of a ballot paper by an elector or obtain or communicate any information as to how an elector is about to vote or has voted;
- I will not directly or indirectly induce an elector to show a marked ballot paper to any person.

SERMENT DU REPRÉSENTANT

Je, soussigné(e), étant autorisé(e) à être présent(e) à ce bureau de scrutin, jure ou affirme solennellement que :

- je garderai et aiderai à garder le secret du vote;
- je n'interviendrai pas auprès d'un électeur qui marque son bulletin de vote et ne tenterai pas de savoir comment un électeur est sur le point de voter ou a voté;
- je n'inciterai pas un électeur, directement ou indirectement, à montrer un bulletin de vote marqué à qui que ce soit.

SWORN OR AFFIRMED BEFORE ME
SERMENT PRÊTÉ OU AFFIRMATION FAITE DEVANT MOI

AT A		
This Ce	day of jour de	year année

DEPUTY RETURNING OFFICER / SCRUTATEUR

SIGNATURE OF PERSON TAKING OATH / SIGNATURE DU DÉCLARANT

FOR DEPUTY RETURNING OFFICER:

AU SCRUTATEUR :

ON COMPLETION OF ALL DUTIES, RETURN THIS DOCUMENT
TO THE COMMANDING OFFICER

APRÈS AVOIR REMPLI TOUTES VOS FONCTIONS,
RETROUVEZ CE FORMULAIRE AU COMMANDANT

PROHIBITIONS – EMBLEMS, FLAGS, CAMPAIGN LITERATURE

No person shall:

- post or display any campaign literature or other material in a polling place or in the exterior surface of a polling place
- while in a polling station, wear any emblem, flag, banner or other object that supports or opposes any candidate or registered party
- influence electors to vote or refrain from voting in a polling station

(s.166 CEA)

SERVICE POLLING STATION SET UP

How to physically arrange the polling station:

- DRO's table (DRO and assistant)
- representatives of political parties - different table but on either side or DRO's table so that they have a clear view of the proceedings
- polling booth (corner - away from the two tables)
- Instructions Cards (EC78120) to be posted in both official languages (at least two copies) – best location is at the polling booth(s)
- Dividers (Elections Canada should send dividers with voting material)
- decorum (quiet location)

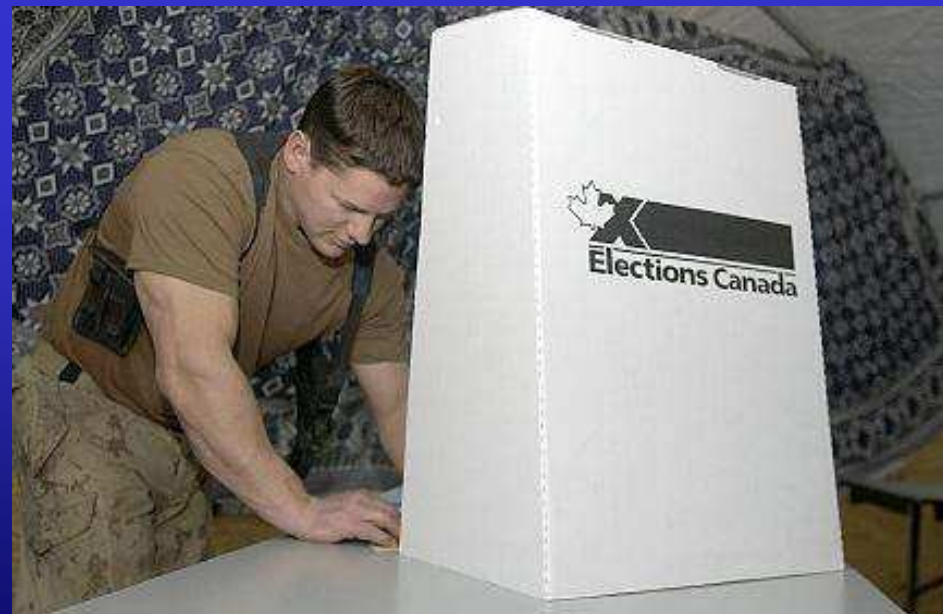

**SETTING UP A POLLING STATION /
MISE EN PLACE D'UN BUREAU DE SCRUTIN**

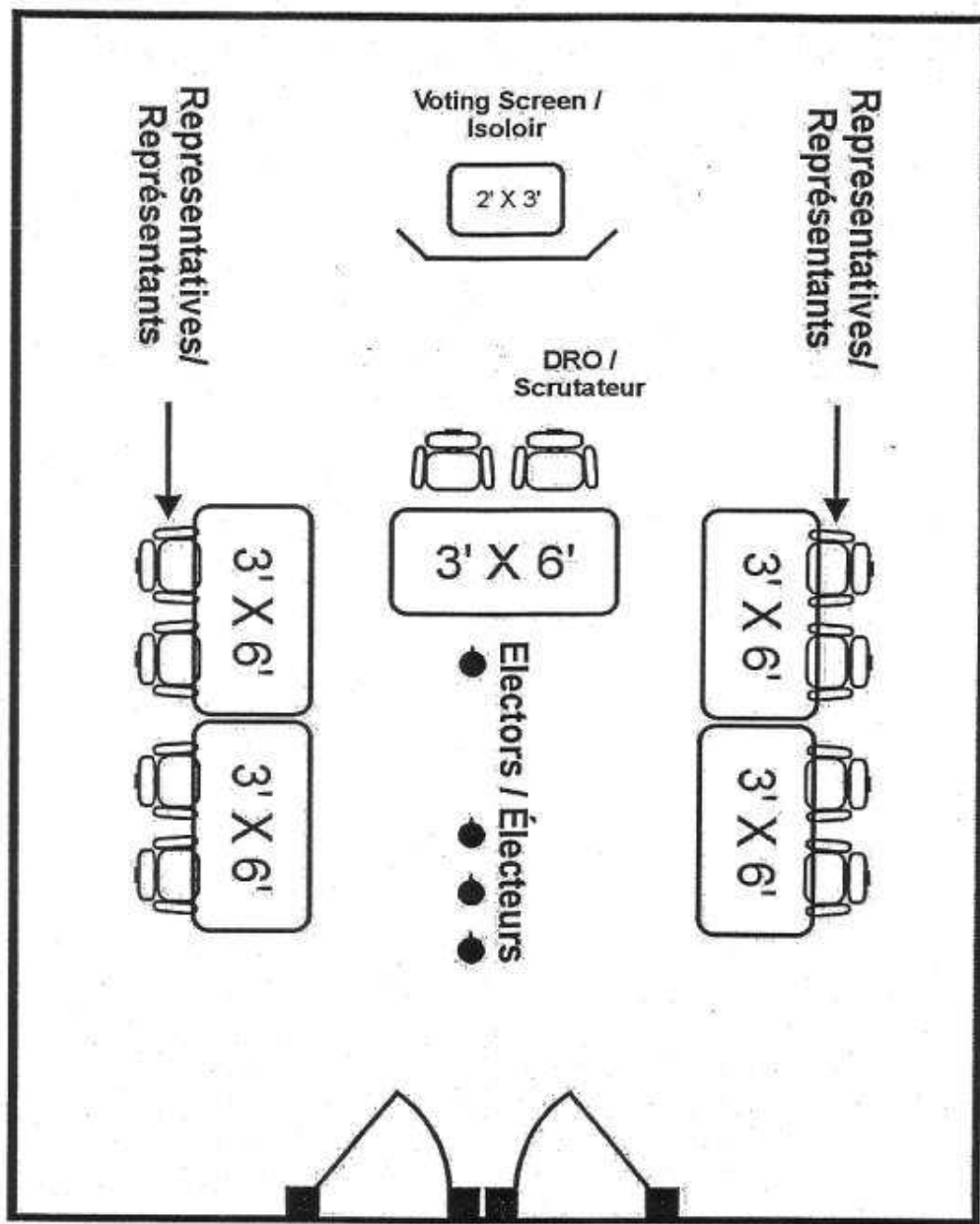

SETTING UP A CENTRAL POLLING PLACE / MISE EN PLACE D'UN CENTRE DE SCRUTIN

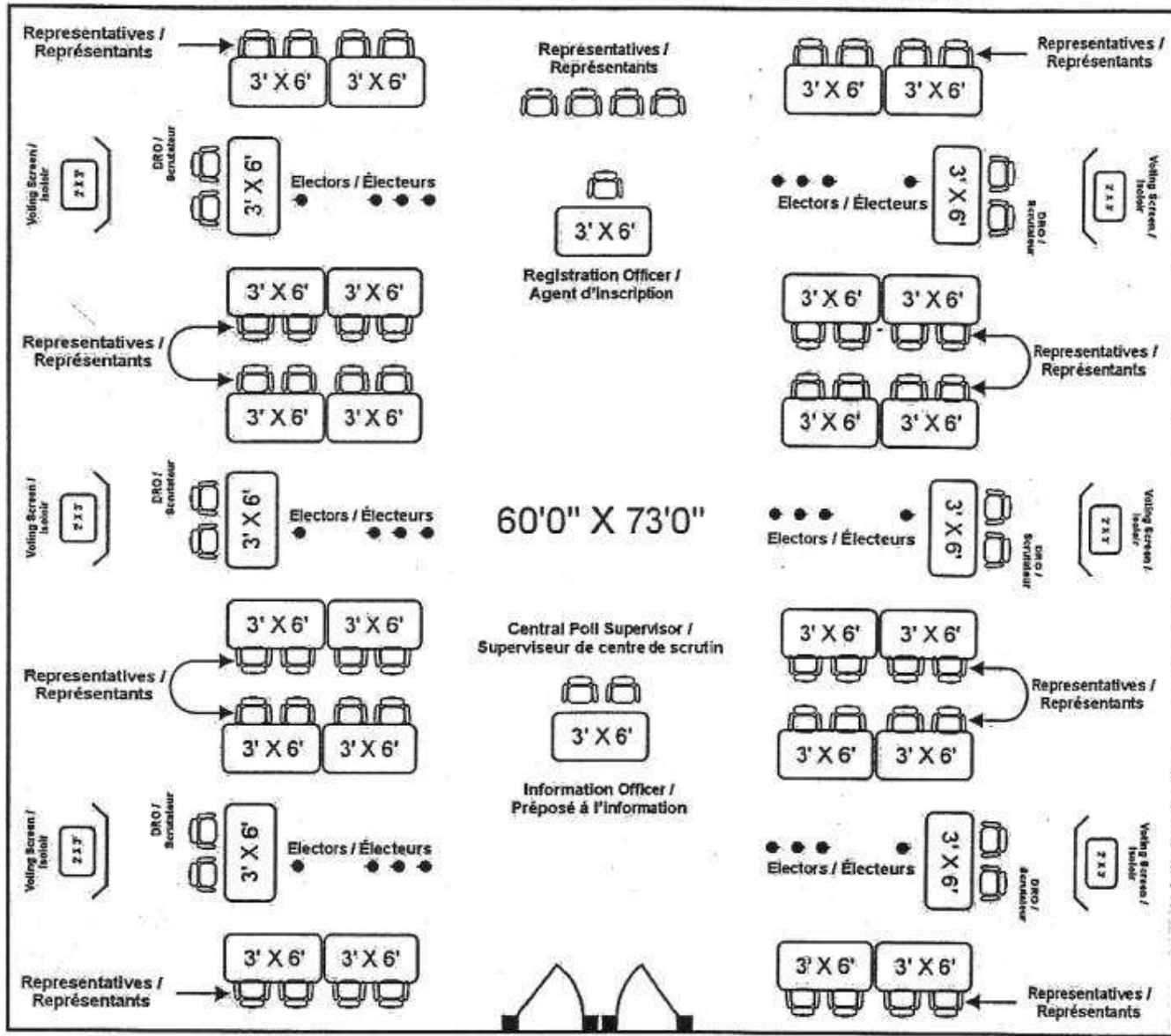

DOCUMENTATION USED TO TAKE THE VOTE

- outer envelope, including at the back of the envelope the declaration signed by the elector
- inner envelope
- ballot paper
- list of names of candidates
- statement of ordinary residence, if required to be completed before voting (Res F members)

QUÉBEC / QUEBEC

24001 Abitibi—Témiscamingue
 24002 Ahuntsic
 24003 Alfred-Pellan
 24004 Argenteuil—Papineau—Mirabel
 24005 Beauce
 24006 Beauharnois—Salaberry
 24007 Beaufort—Lamontou
 24008 Berthier—Maskinongé
 24009 Bourassa
 24010 Brome—Missisquoi
 24011 Brossard—La Prairie
 24012 Chambly—Borduas
 24013 Charlesbourg—Haute-Saint-Charles
 24014 Moutonency—Charlevoix—Haute-Côte-Nord
 24015 Châteauguay—Saint-Constant
 24016 Chicoutimi—Le Fjord
 24017 Compton—Stanstead
 24018 Drummond
 24019 Gaspésie—Îles-de-la-Madeleine
 24020 Gatineau
 24021 Hochelaga
 24022 Honoré-Mercier
 24023 Hull—Aylmer
 24024 Jeanne-Le Ber
 24025 Joliette
 24026 Jonquière—Alma
 24027 Lac-Saint-Louis
 24028 La Pointe-de-l'Île
 24029 LaSalle—Émard
 24030 Laurentides—Labelle
 24031 Laurier—Sainte-Marie
 24032 Laval
 24033 Laval—Les Îles
 24034 Lévis—Bellevue
 24035 Longueuil—Pierre-Boucher
 24036 Lotbinière—Chutes-de-la-Chaudière
 24037 Louis-Hébert
 24038 Louis-Saint-Laurent
 24039 Manicouagan
 24040 Marc-Aurèle-Fortin

24041 Haute-Gaspésie—La Mitis—Matane—Matapédia
 24042 Mégantic—L'Érable
 24043 Montcalm
 24044 Mont-Royal / Mount Royal
 24045 Notre-Dame-de-Grâce—Lachine
 24046 Abitibi—Baie-James—Nunavik—Eeyou
 24047 Outremont
 24048 Papineau
 24049 Pierrefonds—Dollard
 24050 Pontiac
 24051 Portneuf—Jacques-Cartier
 24052 Québec
 24053 Repentigny
 24054 Bas-Richelieu—Nicolet—Béacouac
 24055 Richmond—Arthabaska
 24056 Rimouski-Neigette—Témiscouata—Les Basques
 24057 Rivière-des-Mille-Îles
 24058 Montmagny—L'Islet—Kamouraska—Rivière-du-Loup
 24059 Rivière-du-Nord
 24060 Roberval—Lac-Saint-Jean
 24061 Rosemont—La Petite-Patrie
 24062 Saint-Benoît—Saint-Hubert
 24063 Saint-Hyacinthe—Bégin
 24064 Saint-Jean
 24065 Saint-Lambert
 24066 Saint-Laurent—Cartierville
 24067 Saint-Léonard—Saint-Michel
 24068 Saint-Maurice—Champlain
 24069 Shefford
 24070 Sherbrooke
 24071 Terrebonne—Blainville
 24072 Trois-Rivières
 24073 Veillonville—Soulanges
 24074 Veillonville—Les Patriotes
 24075 Westmount—Ville-Marie

ONTARIO

35001 Ajax—Pickering

35002 Algoma—Manitoulin—Kapuskaing
 35003 Ancaster—Dundas—Flamborough—Westdale
 35004 Barrie
 35005 Beaches—East York
 35006 Bramalea—Gore—Malton
 35007 Brampton—Springdale
 35008 Brampton West / Brampton-Ouest
 35009 Brant
 35010 Burlington
 35011 Cambridge
 35012 Carleton—Mississippi Mills
 35013 Chatham-Kent—Essex
 35014 Durham
 35015 Davenport
 35016 Don Valley East / Don Valley-Est
 35017 Don Valley West / Don Valley-Ouest
 35018 Dufferin—Caledon
 35019 Eglinton—Lawrence
 35020 Elgin—Middlesex—London
 35021 Essex
 35022 Etobicoke Centre / Etobicoke-Centre
 35023 Etobicoke—Lakeshore
 35024 Etobicoke North / Etobicoke-Nord
 35025 Glengary—Prescott—Russell
 35026 Bruce—Grey—Owen Sound
 35027 Guelph
 35028 Haldimand—Norfolk
 35029 Haliburton—Kawartha Lakes—Brock
 35030 Halton
 35031 Hamilton Centre / Hamilton-Centre
 35032 Hamilton East—Stoney Creek / Hamilton-Est—Stoney Creek
 35033 Hamilton Mountain
 35034 Huron—Bruce
 35035 Kenora
 35036 Kingston and the Islands / Kingston et les Îles

35037 Kitchener Centre / Kitchener-Centre
 35038 Kitchener—Conestoga
 35039 Kitchener—Waterloo
 35040 Leamington—Protonac—Lennox and Addington
 35041 Leeds—Grenville
 35042 London—Fanshawe
 35043 London North Centre / London-Centre-Nord
 35044 London West / London-Ouest
 35045 Markham—Unionville
 35046 Lambton—Kent—Middlesex
 35047 Mississauga—Brampton South / Mississauga—Brampton-Sud
 35048 Mississauga East—Cooksville / Mississauga-Est—Cooksville
 35049 Mississauga—Erindale
 35050 Mississauga South / Mississauga-Sud
 35051 Mississauga—Streetsville
 35052 Nepean—Carleton
 35053 Newmarket—Aurora
 35054 Niagara Falls
 35055 Niagara West—Glanbrook / Niagara-Ouest—Glanbrook
 35056 Nickel Belt
 35057 Nipissing—Timiskaming
 35058 Northumberland—Quinte West
 35059 Oak Ridges—Markham
 35060 Oakville
 35061 Oshawa
 35062 Ottawa Centre / Ottawa-Centre
 35063 Ottawa—Orléans
 35064 Ottawa South / Ottawa-Sud
 35065 Ottawa—Vanier
 35066 Ottawa West—Nepean / Ottawa-Ouest—Nepean
 35067 Oxford
 35068 Parkdale—High Park
 35069 Parry Sound—Muskoka
 35070 Perth—Wellington
 35071 Peterborough

35072 Pickering—Scarborough East / Pickering—Scarborough-Est
 35073 Prince Edward—Hastings
 35074 Renfrew—Nipissing—Pembroke
 35075 Richmond Hill
 35076 St. Catharines
 35077 St. Paul's
 35078 Simia—Lambton
 35079 Sault Ste. Marie
 35080 Scarborough—Agincourt
 35081 Scarborough Centre / Scarborough-Centre
 35082 Scarborough—Guildwood
 35083 Scarborough—Rouge River
 35084 Scarborough Southwest / Scarborough-Sud-Ouest
 35085 Simcoe—Grey
 35086 Simcoe North / Simcoe-Nord
 35087 Stormont—Dundas—South Glengary
 35088 Sudbury
 35089 Thornhill
 35090 Thunder Bay—Rainy River
 35091 Thunder Bay—Superior North / Thunder Bay—Superior-Nord
 35092 Timmins—James Bay / Timmins—Baie James
 35093 Toronto Centre / Toronto-Centre
 35094 Toronto—Danforth
 35095 Trinity—Spadina
 35096 Vaughan
 35097 Welland
 35098 Wellington—Halton Hills
 35099 Whitby—Oshawa
 35100 Willowdale
 35101 Windsor—Tecumseh
 35102 Windsor West / Windsor-Ouest
 35103 York Centre / York-Centre
 35104 York—Simcoe
 35105 York South—Weston / York-Sud—Weston
 35106 York West / York-Ouest

**NEWFOUNDLAND AND LABRADOR /
TERRE-NEUVE-ET-LABRADOR**

- 10001 Avalon
10002 Bonaville—Gander—Grand
Falls—Windsor
10003 Humber—St. Barbe—Baie
Verte
10004 Labrador
10005 Random—Beris—St. George's
10006 St. John's East / St. John's-Est
10007 St. John's South—Mount Pearl /
St. John's-Sud—Mount Pearl

**PRINCE EDWARD ISLAND /
ÎLE-DU-PRINCE-ÉDOUARD**

- 11001 Carleton
11002 Charlottetown
11003 Egmont
11004 Malpeque

**NOVA SCOTIA /
NOUVELLE-ÉCOSSE**

- 12001 Cape Breton—Canso
12002 Central Nova / Nova-Centre
12003 Dartmouth—Cole Harbour
12004 Halifax
12005 Halifax West / Halifax-Ouest
12006 Kings—Hants
12007 Cumberland—Colchester—
Missquodoboit Valley
12008 Sackville—Eastern Shore
12009 South Shore—St. Margaret's
12010 Sydney—Victoria
12011 West Nova / Nova-Ouest

**NEW BRUNSWICK /
NOUVEAU-BRUNSWICK**

- 13001 Acadie—Bathurst
13002 Beauséjour
13003 Fredericton
13004 Fundy Royal
13005 Madawaska—Restigouche

- 13006 Miramichi
13007 Moncton—Riverview—Dieppe
13008 New Brunswick Southwest /
Nouveau-Brunswick-Sud-Ouest
13009 Saint John
13010 Tobique—Mactaquac

MANITOBA

- 46001 Brandon—Souris
46002 Charleswood—St. James—
Assiniboia
46003 Churchill
46004 Dauphin—Swan River—
Marquette
46005 Elmwood—Trurocona
46006 Kildonan—St. Paul
46007 Portage—Lisgar
46008 Provencher
46009 Saint Boniface / Saint-Boniface
46010 Selkirk—Interlake
46011 Winnipeg Centre / Winnipeg-
Centre
46012 Winnipeg North / Winnipeg-Nord
46013 Winnipeg South / Winnipeg-Sud
46014 Winnipeg South Centre /
Winnipeg-Centre-Sud

SASKATCHEWAN

- 47001 Battlefords—Lloydminster
47002 Blackstrap
47003 Desnethé—Mississippi—Churchill
River / Desnethé—Mississippi—
Rivière Churchill
47004 Cypress Hills—Grasslands
47005 Palliser
47006 Prince Albert
47007 Regina—Lumsden—Lake Centre
47008 Regina—Qu'Appelle
47009 Saskatoon—Humboldt
47010 Saskatoon—Rosetown—Biggar
47011 Saskatoon—Waskowin
47012 Souris—Moose Mountain
47013 Wascana
47014 Yorkton—Melville

ALBERTA

- 48001 Fort McMurray—Athabasca
48002 Calgary East / Calgary-Est
48003 Calgary Centre-North /
Calgary-Centre-Nord
48004 Calgary Northeast /
Calgary-Nord-Est
48005 Calgary—Nose Hill
48006 Calgary Centre / Calgary-Centre
48007 Calgary Southeast / Calgary-
Sud-Est
48008 Calgary Southwest /
Calgary-Sud-Ouest
48009 Calgary West / Calgary-Ouest
48010 Crowfoot
48011 Edmonton—Mill Woods—
Beaumont
48012 Edmonton Centre / Edmonton-
Centre
48013 Edmonton East / Edmonton-Est
48014 Edmonton—Leduc
48015 Edmonton—St. Albert
48016 Edmonton—Sherwood Park
48017 Edmonton—Spruce Grove
48018 Edmonton—Strathcona
48019 Lethbridge
48020 Macleod
48021 Medicine Hat
48022 Peace River
48023 Red Deer
48024 Vegreville—Wainwright
48025 Westlock—St. Paul
48026 Wetaskiwin
48027 Wild Rose
48028 Yellowhead

**BRITISH COLUMBIA /
COLUMBIE-BRITANNIQUE**

- 59001 Abbotsford
59002 Burnaby—Douglas
59003 Burnaby—New Westminster
59004 Cariboo—Prince George
59005 Chilliwack—Fraser Canyon

- 59006 Delta—Richmond East /
Delta—Richmond-Est
59007 Pitt Meadows—Maple Ridge—
Mission
59008 Esquimalt—Juan de Fuca
59009 Fleetwood—Port Kells
59010 Kamloops—Thompson—Cariboo
59011 Kelowna—Lake Country
59012 Kootenay—Columbia
59013 Langley
59014 Nanaimo—Alberni
59015 Nanaimo—Cowichan
59016 Newton—North Delta /
Newton—Delta-Nord
59017 New Westminster—Coquitlam
59018 Okanagan—Shuswap
59019 North Vancouver
59020 Okanagan—Coquitlam
59021 Port Moody—Westwood—Port
Coquitlam
59022 Prince George—Peace River
59023 Richmond
59024 Saanich—Gulf Islands
59025 Skeena—Bulkley Valley
59026 British Columbia Southern
Interior / Colombie-Britannique-
Southern Interior
59027 South Surrey—White Rock—
Cloverdale /
Surrey-Sud—White Rock—
Cloverdale
59028 Surrey North / Surrey-Nord
59029 Vancouver Centre / Vancouver-
Centre
59030 Vancouver East / Vancouver-Est
59031 Vancouver Island North /
Île de Vancouver-Nord
59032 Vancouver-Kingsway
59033 Vancouver-Quadra
59034 Vancouver South / Vancouver-
Sud
59035 Victoria

- 59036 West Vancouver—Sunshine
Coast—Sea to Sky Country

YUKON

- 60001 Yukon

**NORTHWEST TERRITORIES /
TERRITOIRES DU NORD-OUEST**

- 61001 Western Arctic

NUNAVUT

- 62001 Nunavut

PROHIBITIONS

No person shall:

- knowingly make a false statement in a declaration signed by him or her before a DRO;
- knowingly make a false declaration in the SOR completed by him or her;

No person, who has voted at an election, may request a second ballot at that election (unless the first ballot has been spoiled)

(s.281 CEA)

PROHIBITIONS – CONCERNING BALLOT PAPERS

No person shall:

- provide a ballot to a person unless authorized by law to do so
- have a ballot in his/her possession unless authorized by law to do so

No DRO shall write or mark on any ballot to be given to an elector (with the intent that the elector may be identified)

(s.167(1) & (3) CEA)

PROCEDURES FOR CASTING VOTE



INSTRUCTION CARD

EC 38(2)
(01/02)

FOR CANADIAN FORCES ELECTORS AT A FEDERAL ELECTION OR REFERENDUM

1. You may vote at a federal election or referendum only once.
2. First, the deputy returning officer will hand you an outer envelope. Complete the information requested on this envelope and sign your name under the declaration.
3. After you have signed your name on the outer envelope, the deputy returning officer will hand you a ballot paper and an inner envelope. At an election, the deputy returning officer will also hand you the list of confirmed candidates, opened to the page corresponding to your home riding. Go to the designated private area to mark your ballot.
4. At an election, write with a pen or pencil the given name(s) or initial(s) and surname of the candidate of your choice in the space provided for that purpose on the ballot paper. If there are two or more candidates with the same name, you will also write in the candidate's political affiliation. Fold your ballot paper and go back to the deputy returning officer.

At a referendum, make an "X" in the space corresponding to the word "yes" or "no" in answer to the referendum question on the ballot. You must then fold the ballot paper and return it to the deputy returning officer, who will remove the numbered counterfoil and return the ballot to you.
5. In the presence of the deputy returning officer:
 - a) insert the folded ballot paper in the inner envelope and seal it; and
 - b) insert the inner envelope in the outer envelope and seal it.
6. Transmit the completed ballot, sealed in the inner and outer envelopes, to Elections Canada by mail or by other such means as directed by the deputy returning officer. By law, to be counted, the completed ballot must be received by Elections Canada in Ottawa no later than 6:00 p.m., Ottawa time, on civilian polling day.
7. Should you inadvertently spoil a ballot paper, you must return it to the deputy returning officer, who will hand you another ballot paper. This can only be done once.
8. Your vote will not be counted if:
 - Your ballot paper is marked for more than one candidate or referendum option
 - At an election, you have only voted for a political party and not a candidate
 - Your ballot paper contains a mark by which you can afterwards be identified.

PROCEDURES FOR CASTING VOTE

- DRO requests that elector completes and signs outer envelope indicating correct electoral district in which elector will vote
- If no SOR, elector may complete one of the following :
 - EC78000/DND 406 - Regular Force/Civilian Teachers/Staff
 - EC78020/DND 407 - Reserve Force
- NOTE: Every Regular Force member must have an SOR form already completed.
- Ballot paper, inner and outer envelopes, and list of candidates to elector
- Write given names or initials and surname of candidate
- Elector seals all envelopes in presence of DRO
- Must be received by SVRA / Military Vote Coordinator no later than 18h00 on civilian polling day (**2 May 2011**)
- Postage paid
- Only one spoiled ballot allowed

PROCEDURES FOR CASTING VOTE CASE: WHEN CF ELECTOR'S NAME ONLY IS REFLECTED ON THE LIST

DRO asks elector if he/she has completed an SOR -

- (a) if no, then must complete one before voting. Determine the electoral district of the elector by using the Guide to Federal Electoral Districts and the Street Indexes
- (b) if elector states that he/she has completed an SOR:
 - Ask someone in the elector unit's orderly room to find out the elector's current SOR and confirm the address/ electoral district reflected of the statement

PROCEDURES FOR CASTING VOTE

- 1 - Elector presents himself/herself at the polling station and gives his/her service number, rank, name and initials to DRO. DRO checks the elector's identification card (ID).

- 2 - DRO checks if elector is on the list of CF electors.
 - (a) When elector's name is not on the list, follow procedure at p.15 of DRO Manual.

 - (b) When the elector's address and electoral district are not on the list, follow procedure at p. 14 of DRO Manual

- 3 - When the elector' name is on the list, DRO writes the assigned electoral district on the back of the outer envelope.
 - when elector's name is not on the list, record, at the end of the unit list, the service number, rank, surname, initials, unit, and the electoral district of the elector.

PROCEDURES FOR CASTING VOTE

- 4 - DRO records the elector's electoral district and the appropriate code for the electoral district. Asks elector to read the back of the outer envelope, to complete (name - John Smith - unit must be identified with location where deployed e.g. 1 PPCLI/TFA Battle Group, Afghanistan) sign and date the outer envelope before him/her. (The date confirms that elector voted within the service voting period).
- 5 - DRO ensures that electoral district recorded on list of CF electors and outer envelope matches and that elector's name is struck from the list.
- 6 - DRO ensures that elector's signature and date appear on the outer envelope (IMPORTANT NOTE: **If signature is missing, or if the electoral district cannot be ascertained or that the correct electoral district of the elector cannot be ascertained, the ballot will not be counted** (s.267(1)(b) (c))
- 7 - DRO hands the elector a ballot paper, an inner envelope, the outer envelope bearing the signature of the elector and the list of confirmed candidates

PROCEDURES FOR CASTING VOTE

- 8 - The list of candidates must be turned to the pages corresponding to the elector's electoral district.
- 9 - The DRO informs the elector that he/she must write on the ballot, the given name(s) or initials and surname of the candidate of his/her choice
 - if two or more candidates have the same name, the elector must also write the political party or the word “independent”, as the case may be.
- 10 - The DRO informs the elector that if the elector votes for a political party only, the vote will be rejected.
- 11 - The elector then goes to a separate table (with Elections Canada Voting Screen - cardboard) to mark and fold the ballot paper

PROCEDURES FOR CASTING VOTE

12 - If elector has inadvertently spoiled the ballot:

- DRO marks the returned ballot paper as spoiled, without unfolding it, and places it in the Spoiled Ballot Papers Envelope (EC 78270)
- DRO hands another ballot paper to the elector

N.B.: Only one other ballot may be given to the elector after a ballot paper has been spoiled (s.213(5) CEA)

13 - The elector returns to the DRO's table and, in plain view of the DRO, the elector must:

- insert the folded ballot paper into the inner envelope
- seal the inner envelope
- insert the inner envelope into the outer envelope
- seal and hand you the outer envelope

PROCEDURES FOR CASTING VOTE

- 14 – DRO informs the elector where to deposit the envelope which you will send to the SVRA in Ottawa, following arrangements made by your unit's CO.
- 15 – DRO informs the elector that he/she may mail the envelope personally. DRO must provide postage and advise the elector:
- (a) that in order to be counted, the outer envelope must be received by the SVRA in Ottawa no later than 1800 hours on civilian polling day (2 May 2011)
 - (b) of the nearest post office or mail box.
- 16 - (a) DRO arranges to return outer envelopes by priority post, courier or other means as often as practicable and not in bulk at the end of the service voting period
- (b) Confirm the number of completed outer envelopes to your LO by fax
 - (c) Complete a DND 728 Form to confirm what you are sending to SVRA

OUTER ENVELOPE

DID YOU SIGN AND DATE THIS ENVELOPE?
AVEZ-VOUS SIGNÉ ET DATÉ CETTE ENVELOPPE?

Your ballot will not be counted
if this envelope is not signed.

Votre bulletin ne comptera pas
si cette enveloppe n'est pas signée



OUTER ENVELOPE
FOR CANADIAN FORCES ELECTORS

ENVELOPPE EXTÉRIEURE POUR LES
ÉLECTEURS DES FORCES CANADIENNES

EC 78200
(10/04)

Name of elector / Nom de l'électeur		Service No.(SN)/No. de matricule(NM):
Electoral district NAME / NOM de la circonscription		
Electoral district CODE / CODE de la circonscription		
Unit name / Nom de l'unité		
<p>Declaration</p> <ul style="list-style-type: none"> - I am a Canadian citizen; - I will be 18 years or older on polling day; - I have not previously voted and will not attempt to vote again at the pending electoral event; - My name is as stated above. 		<p>Déclaration</p> <ul style="list-style-type: none"> - J'ai la citoyenneté canadienne; - J'aurai au moins 18 ans le jour du scrutin; - Je n'ai pas déjà voté et ne tenterai pas de voter de nouveau au scrutin en cours; - Mon nom est tel qu'il apparaît ci-haut.
<p>X _____</p> <p>Signature of elector / Signature de l'électeur</p>		<p>_____</p> <p>Date</p>
To be signed only when an elector has received help in voting. / À signer seulement si l'électeur a obtenu de l'aide pour voter.		
<p>_____</p> <p>Signature of Deputy Returning Officer / Signature du scrutateur</p>		<p>_____</p> <p>Signature of Witness / Signature du témoin</p>

DECLARATION/DÉCLARATION

Outer Envelope For Canadian Forces Electors/ Enveloppe extérieure pour les électeurs des Forces canadiennes

EC 78200 (10/04)

Name of elector/Nom de l'électeur
Electoral district name/Nom de la circonscription
Electoral district CODE/CODE de la circonscription
Unit name/Nom de l'unité

Declaration/Déclaration

- I am a Canadian citizen/J'ai la citoyenneté canadienne;
- I will be at least 18 years old on polling day/J'aurai au moins 18 ans le jour du scrutin;
- I have not previously voted and will not attempt to vote again at the pending electoral event/Je n'ai pas déjà voté et ne tenterai pas de voter de nouveau au scrutin en cours;
- My name is as stated above/Mon nom est tel qu'il apparaît ci-haut

Signature of elector/Signature de l'électeur

Date

To be signed only when an elector has received help in voting/À signer seulement si l'électeur a obtenu de l'aide pour voter.

Signature of Deputy Returning Officer/Signature du scrutateur

Signature of Witness/Signature du témoin

CALENDAR - CRUCIAL DATES FOR LIAISON OFFICERS/DEPUTY RETURNING OFFICERS

		<u>REF</u>
Issuance of Writs	26 March 2011	
Lists of CF electors and names of DROs prepared by COs to be forwarded by LOs to SVRA	2 Apr 2011	Para. 41(a) and 42(b) of CFAO
First Notice: General notice – writs	At the earliest opportunity	S. 204 of the CEA
Second Notice: Notice to be issued by COs establishing service voting period, which will set locations, dates and times	15 Apr 2011 or earlier	S. 208 of the CEA and Para. 41(b) of CFAO (to be posted and published in routine orders)
Briefing to DROs	Between 11 – 15 Apr 2011	Depending on the area
Voting material to be with DROs (1 week before voting period) SVRA in Ottawa will send	TBD by SVRA (See Elections Canada Calendar) 11 Apr 2011	
List of candidates to be issued by DND/CF Coord Offr through CANELECTGEN	14 -15 Apr 2011	

CALENDAR - CRUCIAL DATES FOR LIAISON OFFICERS/DEPUTY RETURNING OFFICERS

		<u>REF</u>
<u>Service</u> Voting Period (DAY 14 to 9)	18 Apr to 23 Apr 11 inclusive	s. 190, 205(3) and 208 of the CEA Minimum: 3 days 3hrs/day
DRO after action report to LO	29 Apr 11	
<u>Completed</u> ballots received by SVRA in Ottawa by 1800 hrs	2 May 11	s. 214 of the CEA
<u>Civilian</u> Polling day	2 May 11	
All other unused material, including ballot stubs and spoiled ballots to SVRA in Ottawa	12 May 11	
LO After Election Report to – their respective HQ Voting Area	4 May 11	
Consolidated Sr LO After election Report to JAG Coord Offr SVR	No later than 16 May 11	
Detailed expenses from DROs and LOs to voting area HQ	19 May 11	Required for all DROs/LOs
Detailed expenses report to JAG (no later than 5 weeks after polling day)	17 Jun 11	From MCpl M. Pelletier to JAG/Coord Offr

FINANCIAL ADMINISTRATION

Cost Recovery Policy

DFASO Financial Instruction

Reporting Requirements

DROs and LOs must ensure cost recovery reports are submitted to the Fin Clerk (MCpl M. Pelletier), HQ Voting Area Central, Ottawa, through the LO of your voting area, no later than 19 May 11.

Points of Contact at DCMFA:

(First POC) DCMFA 3: Claire Gauthier (613) 992-2947

(Second POC) DCMFA 3-3: Sheila Bennett (613) 992-5741

Fax for all POCs: (613) 996-2931

POLITICAL ACTIVITIES BY CF MEMBERS - RESTRICTIONS

Prohibited activities:

No member of the Regular Force shall:

- (a) take an active part in the affairs of a political organization or party;
- (b) make a political speech to electors, or announce himself or allow himself to be announced as a candidate, or prospective candidate, for election to the Parliament of Canada or a provincial legislature; or
- (c) except with the permission of the Chief of Defence Staff (CDS), accept an office in a municipal corporation or other local government body or allow himself to be nominated for election to such office.

(QR&O 19.44(7))

POLITICAL ACTIVITIES BY CF MEMBERS - RESTRICTIONS

No officer or non-commissioned member shall organize or take part in a political meeting on a defence establishment

NOTES

Examples of meetings or speeches that might be considered to be political meetings or political speeches are those that are designed to:

- (a) solicit votes for a candidate in a federal, provincial or municipal election;
- (b) solicit funds to support a candidate in a federal, provincial or municipal election or a political party; or
- (c) organize a lobby to maintain or change public policy at the federal, provincial or municipal level.

POLITICAL NEUTRALITY – CANADIAN FORCES AND CF MEMBERS

CF members shall ensure at any time that their acts and conduct do not affect the actual or perceived neutrality of the CF.

(para. 7 of CFAO 99-9)

Osborne v. The Treasury Board – Supreme Court of Canada –
1991 ruling

- reiterated the requirement of having an impartial Public Service
- Public Service employees must be able to perform their duties with impartiality

POLITICAL ACTIVITIES BY CF MEMBERS

Activities permitted:

- attend and vote at a political meetings and conventions, while not in uniform
- register and vote at elections
- be a member of a political party
- make contributions to a political party or to a candidate's election campaign fund
- display political signs, except in areas owned, occupied or controlled by DND or the CF

POTENTIAL QUESTIONS

- Non-validated SOR
- CF elector on leave who does not know his electoral district/with no leave pass
- Amendment to SOR (Regular Force) and new SOR (Reserve Force)
- Elector says the list is wrong
- Preparation of lists per unit
- SOR for teachers and school administrative staff

WEBSITES

Office of the Judge Advocate General (JAG):

Intranet: jag.mil.ca

Internet: www.forces.gc.ca/jag

-- Click on “**Estates and Elections**” menu button

Elections Canada:

Internet: www.elections.ca

CONTACT NAMES/NUMBERS
HQ OTTAWA - CENTRAL VOTING AREA/SVRA ELECTIONS CANADA
and DND Coord SVR

(SVRA) Ms. Lyne Morin
Special Voting Rules Administrator

Phone: (613) 991-2044
Cell: (613) 850-8493
E-mail: lyne.morin@elections.ca

Fax: (613) 998-8393
Toll free 1-800-363-4796

Military Vote Coordinator

Mr. Michel Lefebvre

Phone: (613) 949-3100
Cell: (613) 808-7901
E-mail: michel.lefebvre@elections.ca

Fax: (613) 949-4366 or
Toll free 1-888-770-2062

DND Coord Offr

Col Vihar Joshi

Phone: (613) 995-2628
Cell: (613) 608-3607
E-mail: Vihar.Joshi@forces.gc.ca

Fax: (613) 995-3155

DND Deputy Coord Offr

LCol Roger Strum

Phone: (613) 995-2102
E-mail: Roger.Strum@forces.gc.ca

Fax: (613) 995-3155

Elections Administration Officer

Suzanne Touchette

Phone: (613) 992-0073
E-mail: Suzanne.Touchette@forces.gc.ca

Fax: (613) 995-3155

Assistant to the Elections Administration Officer

Natalie Payant

Phone: (613) 992-1010
E-mail: Natalie.Payant@forces.gc.ca

Fax: (613) 995-3155

CONTACT NAMES and NUMBERS **LIAISON OFFICERS - 5 VOTING AREAS**

1. Voting HQ Ottawa

Deployed Operations

Cdr DM. Peters

Tel: (613) 945-2305

Fax: (613) 945-2304

E-mail:

Darrell.Peters2@forces.gc.ca

(Québec)

LCol L. Gagnon

Tel: (613) 996-9148

Fax: (613) 995-1032

E-mail:

Lucy.Gagnon@forces.gc.ca

NDHQ Ottawa

Cdr P. McCabe

Tel: (613) 995-5989

Fax: (613) 996-7326

E-mail:

Paul.Mccabe@forces.gc.ca

(Ontario)

LCol K. Gash

Tel: (613) 996-0352

Fax: (613) 996-0529

E-mail: Kelly.Gash@forces.gc.ca

(RMS Finance - Ottawa)

MCpl M. Pelletier

Tel: (613) 995-1577

Fax: (613) 996-7326

E-mail: Michel.Pelletier7@forces.gc.ca

CONTACT NAMES/NUMBERS

LIAISON OFFICERS - 5 VOTING AREAS

2. Voting HQ Edmonton

CLS (Land)

LCol Bruno Vanasse
(Edmonton)

Tel: (780) 973-4011 ext. 6002

CSN 528-6002

Fax: (780) 973-1900

E-mail:

[Bruno.Vanasse@forces.gc.ca](mailto: Bruno.Vanasse@forces.gc.ca)

CAS (Air)

LCol Steven Power
(Cold Lake)

Tel: (780) 840-8000 ext 8101

CSN 690-8101

Fax: (780) 840-4811

E-mail:

[Steven.Power@forces.gc.ca](mailto: Steven.Power@forces.gc.ca)

CMS (Navy)

Cdr D. MacKeen
(Esquimalt)

Tel: (250) 363-4017

CSN 333-4017

Fax: (250) 363-5602

E-mail:

[Doug.Mackeen@forces.gc.ca](mailto: Doug.Mackeen@forces.gc.ca)

CONTACT NAMES/NUMBERS

LIAISON OFFICERS - 5 VOTING AREAS

3. Voting HQ Halifax

CLS (Land)

LCol Joël Pilotte

Tel: (902) 427-0735

CSN: 427-0735

Fax: (902) 427-7275

E-mail:

Joel.Pilotte.@forces.gc.ca

CAS (Air)

LCol S. Connor

Tel: (902) 720-1284

CSN: 720-1284

Fax: (902) 720-3207

Email:

Sid.Connor@forces.gc.ca

CMS (Navy)

Maj R.G. Doucet

Tel: (902) 721-8114

CSN: 721-8114

Fax: (902) 721-0330

E-mail:

Rod.Doucet@forces.gc.ca

CONTACT NAMES/NUMBERS

LIAISON OFFICERS - 5 VOTING AREAS

4. Voting HQ CFSU(E) Geilenkirchen **(Germany)**

(RMS – Admin)

LCol J.M.S. Turbide

Tel: +49-2451-717100

Fax: +49-2451-65505

Email:

Sylvain.Turbide@forces.gc.ca

Cpl Tina Francis

Tel: 011-49-2451-717132

Fax: 011-49-2451-65505

Email:

Tina.Francis@forces.gc.ca

CONTACT NAMES/NUMBERS **LIAISON OFFICERS - 5 VOTING AREAS**

5. Voting HQ Washington

Maj Verna Wirth

Tel: (202) 682-7640

CSN: 312-251-7640

Fax: (202) 682-7643

Email:

Verna.Wirth@forces.gc.ca

(RMS – Admin)

MS C.N. Kelly

Tel: (202) 448-6252

CSN: 312-251-7459

Fax: (202) 682-7673

Email:

Corrina.Kelly@forces.gc.ca