

ITS SERVICE BOOK

ITS917 WILDLIFE DETECTION AND WARNING SYSTEM

Purpose

The Wildlife Detection and Warning System utilize a combination of roadside technologies to monitor, detect, and warn of wildlife that may be encroaching a stretch of travelled roadway. Furthermore, it can help to identify points of weaknesses along fence lines where the wildlife is entering the right of way.

Thousands of Animal-Vehicle Collisions (AVCs) are reported each year on provincial highways and pose a major safety hazard.

The targeted animals include:

- Deer, Elk, Moose, Bear, etc.

The objectives of a Wildlife Detection and Warning System are to:

- Reduce animal-vehicle collisions
- Reduce animal and human deaths and injuries resulting from the collisions
- Minimize impact to an animal species

Considerations for Use

Wildlife Warning and Detection Systems can be considered for highways/freeways located in unbuilt areas.

Although ITS provides the opportunity for significant benefits, other non-ITS options may be considered in concurrence or as a precursor to help deter wildlife traffic onto roadways. These options may include:

- Exclusion fencing
- Wildlife escape ramps
- Signage
- Reflectors
- Highway design
- Driver education

Notwithstanding the non-ITS options, the following decision tree provides a method for determining the need for Wildlife Detection and Warning Systems on Ontario roads.

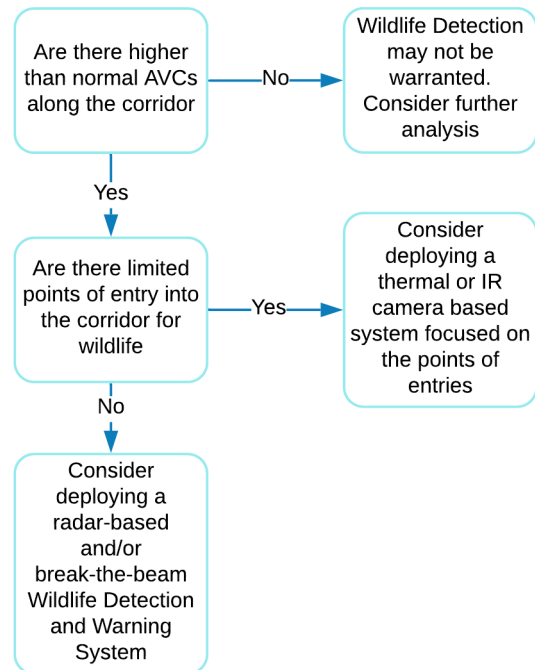

ITS Service Applicability and Limitations of this Service Book

This Service Book may be used in conjunction with other related MTO ITS Services that may have Service Books associated with them.

Limitations

This Service Book may be used in conjunction with other Service Books that have been developed.

This Service Book will aid in determining the need, for a Wildlife Detection and Warning System. Further analysis, specific to the application, is encouraged.

While technologies and data sources continue to evolve, this Service Book references technologies open to using by the MTO.

System Components

The key components of a Wildlife Detection and Warning System are:

- **Detection/Verification** – a means to monitor, detect, and verify wildlife along a corridor

- **Processing**—a means to process the detection data for Operations, Maintenance and/or Traveller Information
- **Traveller Information** – a means to convey to travellers the warning messages associated with the conditions

Detection/Verification

A variety of technologies are available to detect/verify the presence of wildlife within a right of way. It is important to detect the animal's location and where the wildlife may be relative to the roadway. Corridor right-of-way may extend tens of metres beyond the edge of travelled lane requiring a vast detection zone.

This section details technology that has been deployed or is planned to be piloted by the MTO.

The various technologies may be deployed in isolation, but typically are deployed in tandem. False positives may occur through radar/thermal detection, and additional cameras provide the ability to verify the presence of animals and monitor the efficiency of the system.

Radar

Radar uses roadside-mounted technology and can differentiate between wildlife, vehicles, and people. Radar provides 360-degree coverage and a radius of up to 700 metres.

Break the Beam

Break the beam systems utilize a linear line of sight between adjacent transceiver units using infrared or laser technology. Transceivers are typically spaced on straight stretches of the roadway at 150-200 metres at heights based on the target wildlife. A break in a beam triggers an output which may actuate sign messages and/or log the event to a local/central server.

Break the beam systems may be prone to false positives which may impact the credibility of the system.

Video Cameras

Video cameras outfit with video analytics capabilities can detect wildlife. Camera specifications may vary based on the application but consider:

- Pan-tilt-zoom (PTZ) vs. Fixed camera
- Infrared (IR) illumination range
- Camera focal lengths to meet detection zone and inter-camera spacing needs
- On-board analytics vs. central analytics depending on availability of bandwidth and streaming rate

Video cameras provide limited coverage compared to thermal imagers but come at a lower cost. Video cameras can be used for detection and/or verification purposes.

Thermal Imagers

Thermal Imagers outfit with analytics provides the ability to detect wildlife with typically higher rates of success than video cameras. Thermal imager specifications may vary based on the application but consider:

- PTZ vs. Fixed camera
- Viewing distance
- Focal lengths to meet detection zone and inter-camera spacing needs
- On-board analytics vs. central analytics (may depend on the availability of bandwidth and required streaming rates)

Thermal imagers can cover longer ranges than typically video cameras but are at a higher cost. These cameras can be used for detection and/or verification purposes



Processing

On-site Processing

Considering many Wildlife Detection and Warning Systems are warranted in rural areas, it is important for the system to be able to operate autonomously due to potential delay or lack of ability to communicate to a central point. Processing may be performed by an on-site server or a system depending on the type of detection scheme implemented.

Alerts sent to a central operator provide the ability to verify through a video stream from the on-site cameras.

Traveller Information

An application programming interface (API) or the use of digital outputs provide the ability to share and interface data to Traveller Information Systems:

Dynamic Message Signs

- Digital/hybrid message signs upstream of the detection zone relay relevant information via messages to approaching travellers

OPP/Media

- Communication with media partners/OPP for education campaigns

Architecture

The following architecture provides an overview of the system components, their interaction and the flow of information. Note more than one detection technology can be integrated together to improve overall reliability.

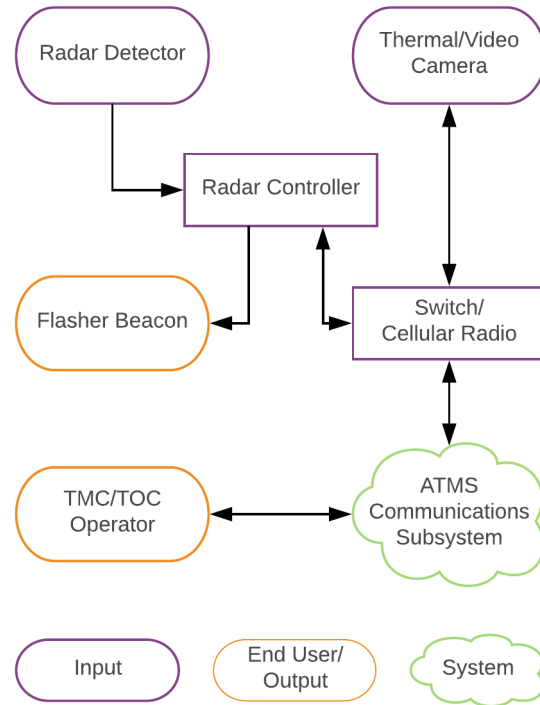

Traffic Management

Wildlife Detection and Warning Systems can operate autonomously between the various cameras, sensors in the field and the DMS. TMC/TOC will have access to on-site cameras to verify and/or override the system when warranted.

Concept

An example concept of a Wildlife Detection and Warning System is shown below using radar.

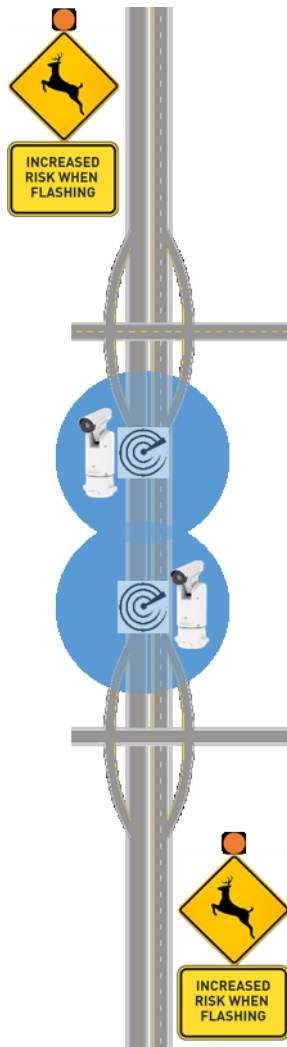

Deployment Considerations

The following are some considerations as part of the deployment of Wildlife Detection and Warning Systems:

- Utilize existing infrastructure for mounting where possible. This may include poles and existing sign supports
- Utilize existing infrastructure for power and communications where possible
- For solar-powered applications, consider areas exposed to sunlight throughout the day

- Try to place wildlife detectors as close as possible to the area prone to wildlife and/or history of collisions
- Consider geometric constraints, sightlines, and local grading when placing traveller information
- Place upstream DMS within 2 km of the detection area
- For longer sections of roadway prone to wildlife, deploy multiple DMS signs along the corridor, especially after on-ramps
- Ensure messages are reset once the wildlife is no longer within the detection zone
- Consider maintenance roles, responsibilities, and processes for each component
- Consider safe maintenance access while locating the equipment
- Consider distance thresholds from the roadway to trigger alerts
- CCTV camera monitoring is recommended to verify detections and any false positives
- PTZ thermal imagers or cameras with IR should be considered for monitoring purposes to allow for flexible viewing to match the radar coverage area

Messaging Examples

Examples of existing messages are limited but the system being piloted by MTO is similar to that of TranBC

Wildlife Warning (Hwy 26)



Wildlife Warning (Northeastern Region)



Wildlife Warning (Eastern Region)



Costs and Procurement Strategy

Budgetary costs are provided below for system components. A combination of the components can help to provide an estimate for a specific application.

However, there may be additional costs to integrate the system to the MTO’s TMC/TOC Operations and associated systems.

Refer to HiCo for additional details and regional estimates.

Element	Cost (2019)
Purchase: Supply and Install	
Radar Detector	\$30,000
Thermal Camera	\$25,000
Break the Beam System	\$100,000 per km
Dome Camera	\$5,000

Element	Cost (2019)
Cabinet Enclosure	\$1,000
Solar Power Kit	\$3,000
Cellular Modem	\$1,000
Static Sign with Flasher Beacons	\$3,000
RF Communicator Set	\$3,000
Portable VMS	\$30,000
Hybrid Static/Variable Sign	\$6,000
Civil Provisions (Ducts, F/O, Power)	\$150,000 per km
9.0 m Concrete Pole	\$2,800
9.0 m Wood Pole	\$1,800
Traffic Control (per lane closure)	\$4,000
Operations and Maintenance	
Cellular Fees (if applicable)	\$75 per month
Maintenance of signs, cabinets, detectors, etc.	~10% of capital/year

Sample Cost Deployment

An example of a Wildlife Detection and Warning System for a section of roadway prone to animal collisions may consist of:

- Detection/Verification Technology
 - 1 x \$30,000 = \$30,000 (radar)
 - 1 x \$25,000 = \$25,000 (thermal)
- Miscellaneous
 - 1 x \$2,800 = \$2,800 (pole)
 - 1 x \$1,000 = \$1,000 (cabinet enclosure)
 - 1 x \$10,000 = \$10,000 (server/software)
 - 1 x \$1,000 = \$1,000 (cell modems)
 - 2 x \$3,000 = \$6,000 (static sign with flashers)
 - 2 x \$3,000 = \$6,000 (RF set)
- Power, Communications, and Civil
 - \$15,000 (miscellaneous civil works)
- Total Deployment = \$96,800 for one station

System Life Cycle

The expected life cycle may range from 5 to 10 years depending on the configuration.

The mean time between failures (MTBF) of relevant equipment for planning, and rehabilitation purposes:

- CCTV Camera – 5 years
- Cellular Modem – 5 years
- Civil Provisions – 25+ years
- Controller Cabinet – 25+ years
- F/O Cable – 25+ years
- Network Switch – 15 years+
- Poles – 25 years+
- Portable VMS – 5 years

Case Studies/Previous Deployments

Description	Components
<p>Highway 416 Large Animal Detection System Ministry of Transportation Ontario</p>	<ul style="list-style-type: none"> • Two (2) 360-degree radar units deployed along Highway 416 near Kemptville • 360-degree radar signal sent out every second with a radius of 700 m • Roadside-flasher beacons actuated upon detection • Drivers reduce speed on average 15% when lights flashing
<p>Highway 17 Wildlife Detection System Ministry of Transportation Ontario</p>	<ul style="list-style-type: none"> • Utilized infrared sensors for a break-the-beam system • Roadside-flasher beacons actuated for 90 seconds upon beam-break • No data currently available to assess the effectiveness • Was prone to false positives and battery issues during winter weather

Description	Components
<p>Wildlife Detection System on Highway 3 Tran BC</p>	<ul style="list-style-type: none"> • Utilize Frequency Modulated Continuous Wave (FMCW) radar technology for detection and thermal and video cameras for verification which would actuate flasher beacons and SLOW DOWN on message sign



Performance Measures

- Reduce the number of AVCs
- Reduce human injuries and fatalities
- Reduce impacts on local animal populations
- Increase in overall mobility due to reduced incidents