



EC2013-625

**ENVIRONMENTAL PROTECTION ACT
SEWAGE DISPOSAL SYSTEMS REGULATIONS**

Pursuant to section 25 of the *Environmental Protection Act* R.S.P.E.I. 1988, Cap. E-9, Council made the following regulations:

- | | |
|--|---|
| 1. (1) In these regulations | Interpretation |
| (a) “bedrock” means a solid or continuous body of rock, with or without fractures, or a weathered or broken body of rock fragments overlying a solid body of rock; | bedrock |
| (b) “certificate of compliance” means a certificate referred to in section 10 respecting completed work; | certificate of compliance |
| (c) “certified” means guaranteed by a Standards Council of Canada Accredited Testing Agency as being in conformance with the latest CSA Standard pertinent to the application of the product; | certified |
| (d) “contractor” means any person, corporation, company, firm, organization or partnership who proposes to perform or engage to perform for his, her or its own benefit or that of another, with or without remuneration or gain, any sewage disposal system work or installation within the scope of these regulations; | contractor |
| (e) “CSA” means the Canadian Standards Association; | CSA |
| (f) “dwelling” means a building or portion thereof designed, arranged or intended for residential occupancy; | dwelling |
| (g) “dwelling unit” means two or more rooms used or intended for domestic use of one or more individuals living as a single housekeeping unit with cooking and sanitary facilities; | dwelling unit |
| (h) “license” means a license issued pursuant to these regulations by the Minister to any person or any contractor; | license |
| (i) “licensed pumper” means a person who holds a pumper’s license; | licensed pumper |
| (j) “licensed septic contractor” means a contractor who holds a septic contractor’s license; | licensed septic contractor |
| (k) “licensed site assessor” means a person who holds a site assessor’s license; | licensed site assessor |
| (l) “Minister” means the Minister responsible for the Department of Environment, Labour and Justice; | Minister |
| (m) “natural boundary” means the visible high water mark of any stream, river, or other body of water; | natural boundary |
| (n) “owner” includes any person, firm, corporation or agent controlling or occupying the property under consideration; | owner |
| (o) “parcel” means any lot, block or other area in which real property is held or into which real property is subdivided and can include two or more adjacent lots, blocks or areas of property upon which a sewage disposal system is being situated; | parcel |
| (p) “permeable soil” means soil having a hydraulic conductivity in the range of 8.0×10^{-3} cm/s to 8.0×10^{-5} cm/s (3.1×10^{-8} in/s to 3.1×10^{-5} in/s); | permeable soil |
| (q) “professional engineer” means a professional engineer as defined in the <i>Engineering Profession Act</i> R.S.P.E.I. 1988, Cap. E-8.1; | professional engineer
pumper’s license |

- (r) “pumper’s license” means a pumper’s license issued under subsection 14(2);
- (s) “registered document” means a written document that sets out site suitability assessment information and information respecting layout and selection of a sewage disposal system as required by the Standards; registered document
- (t) “registered installer” means a person who is employed and supervised by a contractor, and is registered with the Minister as a person qualified to install sewage disposal systems; registered installer
- (u) “restaurant” means a place where meals can be bought and eaten and includes a cafeteria and an institutional kitchen; restaurant
- (v) “septage” means all settled solids, scum, liquid or other material removed from a septic tank or disposal field; septage
- (w) “septic contractor’s license” means a septic contractor’s license issued under section 4; septic contractor’s license
- (x) “septic tank” means a watertight receptacle that receives sewage which is designed and installed to permit settling of settleable solids from the sewage, retention of the solids and scum, partial digestion of the organic matter, and discharge of the liquid portion into a disposal field; septic tank
- (y) “sewage” means any human waste emitted from a house or premises where persons work, live or frequent and includes waste from ablutions, culinary activities and laundering; sewage
- (z) “sewage disposal system” includes any system or part thereof for disposing of sewage or waste by means of one or more settling or septic tanks and one or more disposal fields, and any other system or part thereof for sewage or waste disposal not directly connected to a municipal or approved central sewage collection system; sewage disposal system
- (aa) “sewage disposal system installation permit” means a permit for the installation of an on-site sewage disposal system issued under section 7; sewage disposal system installation permit
- (bb) “sewage holding tank” means a closed, water-tight receptacle designed and used to receive and store sewage or septic tank effluent which does not discharge waste water; sewage holding tank
- (cc) “site assessor’s license” means a license issued under section 5; site assessor’s license
- (dd) “site suitability assessment” means an assessment completed on property to determine the suitability of that property for on-site sewage disposal and may include test pit inspection(s) and permeability test(s); site suitability assessment
- (ee) “sludge” means the semi-liquid material that is removed from a wastewater treatment system as an end product of the treatment process; sludge
- (ff) “Standards” means the “Minimum Regulatory Requirements for the Selection and Construction of On-Site Sewage Disposal Systems on Prince Edward Island” set out in the Schedule to these regulations; Standards
- (gg) “unstabilized sewage” means sewage that has been held in a septic tank or a holding tank for less than 30 days. unstabilized sewage
- (2) In these regulations, Imperial measurements are added editorially for convenience and are not intended to be relied on as exact equivalents of the metric measurements specified. Imperial measurements
2. For the purposes of these regulations and the Standards, a Category I, II, III, IV or V lot is a property that has been assessed as such in accordance with the Subdivision and Development Regulations made under the *Planning Act* R.S.P.E.I. 1988, Cap. P-8, in a site suitability assessment completed in accordance with section 11. Categories of property
3. (1) These regulations and the Standards apply to the installation, construction, reconstruction or modification of sewage disposal systems. Application
- (2) Where an existing sewage disposal system is to be expanded or modified, the Minister may by order, for the purpose of protecting public health or the environment, require the entire existing sewage disposal Order re system expansion or modification

system or any part thereof to be modified or replaced in conformance with the provisions of these regulations and the Standards.

LICENSES, REGISTRATION AND PERMITS

- 4.** (1) No person shall install, construct, reconstruct or modify a sewage disposal system, or cause the same to be done, unless the person holds a valid septic contractor's license. Contractor's license
- (2) A person may apply for a septic contractor's license by submitting to the Minister Application
- (a) a completed application in the form approved by the Minister; and
- (b) the fee set out in clause 9(1)(d).
- (3) A septic contractor's license shall be granted to an applicant if Qualifications
- (a) the applicant has submitted an application and the prescribed fee in accordance with subsection (2); and
- (b) the applicant
- (i) has attended a seminar approved by the Minister and has completed and passed an examination administered by the Minister, and
- (ii) holds
- (A) a site assessor's license, or
- (B) a license issued by another province or territory that in the opinion of the Minister is equivalent to a septic contractor's license issued under these regulations.
- (4) No licensed septic contractor shall permit a sewage disposal system to be installed, constructed, reconstructed or modified unless the licensed septic contractor, or a registered installer in the employ of the licensed septic contractor, is present on the job site during the installation, construction, reconstruction or modification. Site supervision
- (5) Where a licensed septic contractor carries out work on a sewage disposal system, or causes it to be carried out, the licensed septic contractor shall ensure that the work is carried out in compliance with the requirements prescribed in these regulations and the Standards. Responsibility
- (6) A septic contractor's license is not transferable. Transfer
- (7) A septic contractor's license expires on the date indicated on the license, which shall not be more than twenty-four months from the date of issuance and may be renewed on payment of the renewal fee set out in clause 9(1)(d). Time frame
- (8) A licensed septic contractor shall attend a seminar approved by the Minister at least once in each two-year period. Seminar
- (9) The Minister may suspend a septic contractor's license for a period of time specified by the Minister, not exceeding the remainder of the period during which the license is valid, if the Minister is satisfied that one or all of the following conditions prevail: Suspension
- (a) the license holder has installed, constructed, reconstructed or modified a sewage disposal system that is not designed, located, installed, constructed, reconstructed or modified in accordance with the requirements set out in these regulations and the Standards;
- (b) the license holder has obtained the license through misrepresentation or fraud;
- (c) the license holder has allowed another person to have the use of the license;
- (d) the license holder has failed to attend a seminar approved by the Minister as required under subsection (8);
- (e) the license holder has failed to submit to the Minister a certificate of compliance for an on-site sewage disposal system pursuant to section 9 of these regulations.
- (10) Where a septic contractor's license is suspended under subsection (9) he or she may reapply to the Minister under subsection (2) upon the expiry of the suspension period specified under subsection (9), subject to an order by the Minister requiring re-examination pursuant to subclause (3)(b)(i). Reinstatement
- 5.** (1) A person may apply for a site assessor's license by submitting to the Minister Site assessor's license

- (a) a completed application in the form approved by the Minister;
and
(b) the fee set out in clause 9(1)(e).
- (2) The Minister shall, on application, grant a site assessor's license to an applicant if Qualifications
(a) the application is made in accordance with subsection (1); and
(b) the applicant has
(i) at least two years of post-secondary education in a related field of study, and
(ii) either
(A) has successfully completed a course of instruction approved by the Minister, or
(B) holds a license issued by another province or territory that the Minister considers to be equivalent to a site assessor's license.
- (3) The Minister may grant a site assessor's license to an applicant under subsection (2), notwithstanding that the applicant does not have the post-secondary education in a related field that is required by that subsection, if the applicant has practical experience in a related field that the Minister considers to be equivalent to that post secondary education. Exception
- (4) A site assessor's license is not transferable. License not transferable
- (5) A site assessor's license expires on the date indicated on the license, which shall not be more than twenty-four months from the date of issuance, and may be renewed on payment of the renewal fee set out in clause 9(1)(e). Expiry
- (6) The Minister may suspend a site assessor's license for the period specified by the Minister, not exceeding the remainder of the period during which the license is valid, if the Minister is satisfied that the license holder has Suspension
(a) obtained the license through misrepresentation or fraud; or
(b) allowed another person to have the use of the license.
- 6.** (1) A person may apply for registration as a registered installer by attending a seminar approved by the Minister and paying the application fee set out in clause 9(1)(f). Registered installer
- (2) The registration for a registered installer is valid for not more than twenty-four months from the date of registration or renewal and may be renewed on payment of the renewal fee set out in clause 9(1)(f). Term
- (3) A registered installer shall attend a seminar approved by the Minister at least once in each two-year period. Seminar
- (4) Any registered installer who fails to attend a seminar approved by the Minister as required under subsection (3) shall cease to be registered. Continuing education
- 7.** (1) A licensed septic contractor who does not hold a valid site assessor's license may apply for a sewage disposal system installation permit by submitting to the Minister Application for permit
(a) a completed application in the form approved by the Minister;
and
(b) the fee set out in clause 9(1)(a).
- (2) No licensed septic contractor who does not hold a valid site assessor's license or owner of a dwelling shall commence the construction, reconstruction, installation or modification of a sewage disposal system, or cause the same to be done, unless Sewage disposal system installation permit required
(a) a sewage disposal system installation permit has been issued pursuant to subsection (1);
(b) the application fee has been paid in full; and
(c) the licensed septic contractor or owner installing the system has a copy of the sewage disposal system installation permit in his or her possession on site.
- (3) Notwithstanding the provisions of subsection (2), a licensed septic contractor may commence the construction, reconstruction, installation or modification of a sewage disposal system without applying for a sewage disposal system installation permit, if Exception
(a) the licensed septic contractor holds a valid site assessor's license;
and

(b) the licensed septic contractor has completed a registered document and submitted it to the Minister.

(4) No person shall install, construct, reconstruct or modify a sewage disposal system unless it is designed, located, installed, constructed, reconstructed or modified in accordance with requirements prescribed in these regulations and the Standards. Construction and installation

(5) The Minister may by order prohibit the construction, reconstruction, installation or modification of a sewage disposal system when, in the Minister’s opinion, weather conditions or ground conditions are unsuitable. Construction prohibited

(6) A professional engineer or a licensed septic contractor who holds a valid site assessor’s license and proposes to install a sewage disposal system shall provide notice to the Minister twenty-four hours prior to commencing the installation of the sewage disposal system. Notice of installation

(7) Upon receipt of a sewage disposal system installation permit, no licensed septic contractor or registered installer shall deviate from the conditions of the permit without prior approval of the Minister. Deviation

(8) A sewage disposal system installation permit issued pursuant to subsection (1) shall be valid for a period of twenty-four months from the date of issue. Permit duration

(9) A professional engineer or a licensed septic contractor who holds a valid site assessor’s license is exempt from the requirements of subsections (1) and (2) and subsection 8(1). Exception

8. (1) No licensed septic contractor who does not hold a valid site assessor’s license, registered installer, owner of a dwelling or other person shall cover a sewage disposal system, or cause the same to be done, without having first served notice to, and received instructions from, the Minister. Covering system

(2) Where the Minister finds that a sewage disposal system has been constructed, reconstructed, installed or modified and covered without permission, the Minister may order the owner of the system or the licensed septic contractor to uncover all or part of the system for inspection. Order to uncover system

9. (1) The fees payable for an application are as follows: Fees

- (a) for an application by a licensed septic contractor for a sewage disposal system permit..... \$100
- (b) for an application for a site suitability assessment per lot..... \$300
- (c) for an application for, or renewal of, a pumper’s license (2 yrs)..... \$250
- (d) for an application for, or renewal of, a septic contractor’s license (2 yrs)..... \$250
- (e) for an application for, or renewal of, a site assessor’s license (2 yrs)..... \$250
- (f) for an application to be registered as a registered installer, or to renew a registration as a registered installer (2 yrs)..... \$ 25
- (g) for submission by a licensed septic contractor of a registered document..... \$100

(2) An inspection fee of \$50 per inspection shall be payable where extra inspections are required Extra inspections

- (a) for reinspection of a sewage disposal system that has been found to have deficiencies;
- (b) for additional requested inspections.

10. Within 60 days of modification, construction, reconstruction or installation of a sewage disposal system, the licensed septic contractor shall furnish a certificate of compliance to the owner and the Minister. Certificate of compliance

11. (1) The Minister may require that the owner of a lot for which an application for a sewage disposal system installation permit has been submitted have a site suitability assessment completed on the lot. Site suitability assessment

(2) A site suitability assessment of a lot shall assess the lot as a Category I, II, III, IV or V Lot in accordance with section 23 of the Categories of lot

Subdivision and Development Regulations under the *Planning Act* in accordance with the standards specified in that section.

12. (1) Subject to subsection (2), no person shall perform a site suitability assessment unless that person holds a valid site assessor's license. Site assessor's license

(2) A person may perform a site suitability assessment without a site assessor's license if the person is Exceptions

- (a) a professional engineer; or
- (b) an environment officer appointed or designated under the *Environmental Protection Act* R.S.P.E.I. 1988, Cap. E-9.

13. Notwithstanding the provisions of these regulations and the Standards affecting the design and location of a sewage disposal system, the Minister may vary those provisions where, because of existing lot size or other reasons, compliance is impossible, except that the variance with respect to setback from a well shall not be reduced by more than 10 per cent of the required distance. Variances

DISPOSAL OF SLUDGE

14. (1) No person shall engage in the cleaning of a sewage disposal system or a wastewater treatment system, or in the spreading of sludge on land, unless the person Sewage disposal system cleaning

- (a) holds a pumper's license issued under this section; and
- (b) complies with the provisions of these regulations.

(2) The Minister shall, on an application for the issuance or renewal of a pumper's license referred to in subsection (1), issue or renew the license if the application Pumper's license

- (a) is made in a form acceptable to the Minister;
- (b) is accompanied by the fee set out in clause 9(1)(c); and
- (c) in the case of an application for renewal of a license, all records have been kept and reports submitted by the applicant as required under subsections (3) and (5).

(3) The holder of a pumper's license shall, in respect of each septic system from which the license holder has removed septage, create and maintain a record in the form approved by the Minister containing the following information: Records

- (a) the civic address of each site where septage has been removed from a septic system;
- (b) the date on which septage was removed from the septic system;
- (c) the volume of septage removed on the date referred to in clause (b); and
- (d) the date of disposal of collected septage and the location of its disposal.

(4) The information referred to in clauses (3)(a) to (d) shall be entered in the record for the septic system to which it pertains immediately after removal of the septage. Entry of information

(5) A person who made, or caused to be made, a record under this section shall submit a written report to the Minister in the form approved by the Minister in respect of removal of septage from septic systems in the preceding calendar year that contains the following information: Report

- (a) the civic address of each sites where septage was removed from a septic system;
- (b) the dates on which septage was removed from each septic system referred to in clause (a);
- (c) the total annual volume of septage removed;
- (d) the location and date of disposal of collected septage.

(6) A person who made, or caused to be made, a record under this section shall Duties respecting records and reports

- (a) retain the record for a period of three years from the date on which the septage was removed from the septic system;
- (b) submit the written report referred to in subsection (5) to the Minister on or before April 1 of each year; and
- (c) make the records referred to in clause (a) available immediately on request to any environment officer appointed under the *Environmental Protection Act* or conservation officer appointed or designated under the *Wildlife Conservation Act* R.S.P.E.I. 1988 Cap. W-4.1.

(7) All licenses granted under this section shall be valid for a period of not more than twenty-four months from the date of issuance. Duration of license

15. (1) The ultimate disposal of sludge from sewage disposal systems or wastewater treatment systems shall be done in accordance with the following conditions: Conditions for disposal

(a) sludge shall not be placed or spread on frozen or snow-covered ground and, during the period of time when the ground is frozen or snow-covered, an alternative method of disposing of sludge, acceptable to the authority having jurisdiction, shall be utilized;

(b) sludge shall not be placed or spread, in the same calendar year, on land to be used for animal pasture or on land to be used to produce crops for human consumption;

(c) sludge shall be spread on the land using a diffuser plate or other equipment acceptable to the Minister;

(d) sludge shall not be placed or spread upon any ground except in accordance with the following criteria:

(i) at least 300 m (1,000 ft) from land zoned for business or residential use,

(ii) at least 300 m (1,000 ft) from any dwelling on adjacent property,

(iii) at least 15 m (50 ft) from the edge of a provincial public highway,

(iv) at least 150 m (500 ft) from any water well,

(v) in respect of distance from any watercourse

(A) at least 15 m (50 ft) where the land slope averages less than 2 per cent,

(B) at least 37 m (120 ft) where the land slope averages between 2 and 5 per cent,

(C) at least 107 m (350 ft) where the land slope averages between 5 and 10 per cent,

(D) at least 213 m (700 ft) where the land slope exceeds 10 per cent.

(2) No person shall place sludge in any holding site without the prior approval of the Minister. Holding of sludge

(3) In accordance with clause (1)(a), the Minister may approve an alternative disposal method or site for sludge disposal, if the Minister is satisfied that the method or the site is suitable for the safe treatment and disposal of the waste. Alternative disposal method

(4) No person shall dispose of unstabilized sewage or septage at any place other than a waste treatment system approved by the Minister. Disposal at waste treatment system

GENERAL

16. Any person who contravenes any provision of these regulations or the Standards, or fails to comply with any condition of a permit or fulfil any obligations imposed on the person by these regulations, the Standards or an order of the Minister, is guilty of an offence and is liable on summary conviction to the penalties specified in section 32 of the *Environmental Protection Act*. Offences

17. (1) The Standards set out in the Schedule to these regulations are hereby adopted and form part of these regulations. Adopting Standards

(2) Unless stated otherwise in a provision of the Standards, a licensed septic contractor is responsible for ensuring that the requirements of the Standards are met in respect of a sewage disposal system installed, constructed, reconstructed or modified by the licensed septic contractor. Responsibility of licensed septic contractor

18. A permit, license or registration for an activity that is required to be licensed, permitted or registered under these regulations that was valid and in force on the coming into force of these regulations remains in force according to its terms until it expires or is suspended pursuant to these regulations. Continuation of license or permit

REVOCATION AND COMMENCEMENT

19. The *Environmental Protection Act* Sewage Disposal Systems Regulations (EC403/03) are revoked. Revocation

20. These regulations come into force on January 1, 2014. Commencement

SCHEDULE

Minimum Regulatory Requirements

for

On-Site Sewage Disposal Systems

on

Prince Edward Island

The following provisions are also set out in Part Two of the On-Site Sewage Disposal Systems, Construction Standards Handbook, published by the Department of Environment, Labour & Justice, under the heading "Minimum Regulatory Requirements for the Selection & Construction of On-Site Sewage Disposal Systems In Prince Edward Island".

Appendix 'A'

Section 1 Standards for Selection of On-Site Sewage Disposal Systems

1.1 Introduction

The following section is intended to be used by Private Site Assessors, Environment Officers (Safety Standards Officers and Qualified Staff) and Licensed Septic Contractors for the sizing and siting requirements for the selection and installation of on-site sewage disposal systems. The Licensed Septic Contractor/Assessor and the Private Site Assessors are permitted to assess and select sewage disposal systems, up to a system size of 6,810 L/day (1,500 Igal/day) categorized as Category I, II, III (bedrock) & IV. The selection of systems up to five bedrooms (2,270 L/day) residential units can be selected from **Table 1.1** and selection tables in **Appendix D (Disposal Field Length Selection Table)** once the soils of the area have been categorized. Septic tank and disposal field sizing requirements from 2,271 L/day up to 6,810L/day can be determined using the **Design Flow Table (Appendix B)** and the **Disposal Field Length Selection Table (Appendix D)**. Systems greater than 6,810 L/day (1,500 Igal/day) *shall be assessed and designed* by a consulting engineer licensed to practice on Prince Edward Island. A qualified engineer can then complete an assessment and design any sized system as desired by the property owner.

A Licensed Septic Contractor, not licensed as a site assessor, and utilizing the permit process must also follow these standards. Under the permit process, licensed septic contractors are required to make application for a permit, receive a closing time and have an inspection carried out, prior to covering the sewage disposal system.

1.1.1 Definitions

alternative multiple trench disposal field - means a multiple trench disposal field oriented across the slope of a property with lateral spacing of no less than 4 metres (13 ft) between the lines;

barrier material - means a light weight (50 g/m² or more) nonwoven (i.e. felted, needle punched or heat bonded fibre) fabric or proprietary geotextile with a permeability greater than 0.001 m/s (0.04 in/sec) and an opening size of less than 700 µm (0.028 in);

capacity - means the liquid capacity of a septic tank between the waterline and the floor of the tank;

contour trench disposal field - means a relatively narrow and shallow disposal bed constructed in a trench of constant depth, with both the trench bottom and the lip of the trench wall at the ground surface horizontal through out the entire length (*see Sections 1.10.6 –1.10.8*);

disposal field - means that part of an on-site sewage disposal system designed and installed in accordance with these regulations for the subsurface distribution of septic tank effluent into the soil;

drainage pipe - means the certified, perforated, rigid, straight, sewer pipe used in a disposal field;

effluent - means sewage after it has passed through a septic tank or some other type of treatment;

effluent line - means a pipe that transports effluent from a septic tank to a disposal field;

existing parcel - means any parcel in existence prior to June 12, 1993;

filter sand - means clean, washed, screened or natural sand having less than 10% by weight retained on a 10 mm (3/8 in) sieve and less than 2% by weight passing a 0.075 mm (#200 US std.) sieve and the permeability of the sand must be not less than 0.0004 m/s (0.0013 ft/s);

good quality fill - means a reasonably uniform sand or sandy gravel containing a small proportion of silt/clay but no more than 30 % of the material shall be retained on a 10 mm (3/8 in) sieve and a minimum of 2.5 % and a maximum of 15% passing the 0.075 mm sieve (#200 US std.);

gravel - means clean, washed or screened small pieces of rock or crushed rock of a consistency or hardness which is not conducive to premature deterioration, and of which 98% by weight shall pass a 40 mm (1½ in) screen and 98% by weight shall be retained on a 12.5 mm (½ in) screen;

grease interceptor tank - means a tank installed in front of the septic tank to remove grease, oil and fats from sewage;

header - means pipe used to connect the ends of lines of drainage pipe or leaching chambers;

leaching chamber - means a prefabricated device approved by the authority having jurisdiction for use in a disposal field as an alternative to gravel and drainage pipe;

leaching chamber disposal field - means a system of leaching chambers arranged in a multiple trench configuration (*see Section 1.10.5*);

liquid depth - means the maximum vertical depth of liquid which a septic tank can contain before the liquid discharges through the septic tank outlet;

multiple family dwelling - means a building containing three or more dwelling units;

multiple trench disposal field - means a system of drainage pipes and gravel arranged in the form of narrow, parallel trenches connected to a header (*see Section 1.10.3*);

permeable soil (natural) - means soil having a hydraulic conductivity in the range of 8.0 x 10⁻³ cm/s to 8.0 x 10⁻⁵ cm/s (3.1 x 10⁻⁸ in/s to 3.1 x 10⁻⁵ in/s);

pressure distribution system - means a distribution system designed such that a pump or siphon supplies septic tank effluent to non-perforated pipe that is drilled with holes of such diameter and spacing that the top header, full length of all interconnecting pipes, and the bottom header are under a positive pressure;

sewer line - means a pipe that transports sewage from a building to a septic tank or a sewer collection main;

standard disposal field - means a multiple trench or alternative multiple trench disposal field;

top header - means the first header of each disposal field to receive effluent from the septic tank (*see Figure 1.9*);

waterline - means the maximum elevation of the liquid in a septic tank;

water table - means the level at which water stands in a shallow well open along its depth and penetrating the surficial deposits just deeply enough to encounter standing water in the bottom (level of water in saturated soil where hydraulic pressure is equal to zero).

1.2 Building Sewers

A building sewer for a single unit dwelling, is defined as the part of the building drainage system carrying sewage that extends from the septic tank or public sewer to a point 900 mm to 1500 mm out from the foundation wall. The building sewer shall be installed with the following conditions:

1. Minimum 100 mm diameter pipe, non-perforated, rigid, smooth bore, watertight joints with gaskets, DR35 CSA certified piping.
2. Laid straight on a grade not less than two per cent.
3. If a change in direction is needed the fittings shall consist of certified, long sweep fittings. The use of these fittings should be limited.
4. Located a minimum 0.5 metres from any potable water service line.
5. Located a minimum of 3.0 metres from a domestic water well.
6. Cleanouts extended to the ground surface shall be provided at intervals of not more than 30 m, if the length of the building sewer exceeds 60 m or any direction change greater than 90 degrees.
7. Install pipe and fittings according to manufacturer's recommendations.

1.3 Septic Tanks and Effluent Lines

The following requirements shall apply to any tank that is selected or designed for use as a septic tank, with respect to construction standards, selection criteria and setback requirements:

1. The septic tank shall be designed to carry a minimum of 600 mm of earth cover.

2. All materials shall be installed according to the manufacturer's recommendations. These recommendations shall be submitted to the department by the manufacturer.
3. The manufacturer of a prefabricated tank shall provide to the installer instructions for assembly and installation of the tank. These instructions shall detail the entire installation process to ensure that the tank is watertight. These instructions shall include, but not limited to, the preparation of excavation, installation of tank, backfilling of tank, connection detail of inlet/outlet piping, etc.
4. The instructions shall be submitted to the department for review to assure that they address the requirements of these Standards.
5. Septic tanks must conform to the latest standard as stated in Canadian Standards Association (CSA). Grease tanks and dosing chambers are not permitted for use as a septic tank, pump or siphon chamber. Acceptable materials are reinforced concrete that conforms to CSA standards and fiberglass and polyethylene tanks which are CSA approved.
6. All septic tanks shall be watertight.
7. All septic tanks shall have risers installed as outlined in the appropriate sections. As a minimum an access riser shall be installed over the outlet and in each chamber, if the tank has multiple chambers.
8. Where a tank is installed in an area where high groundwater levels may occur, the manufacturer shall include instructions to prevent flotation of the tank.
9. A sectional pre-fabricated tank may be assembled on site, provided that the manufacturer's instructions are followed to produce a watertight tank.
10. Where a tank is manufactured from concrete, the bung hole must be sealed in a watertight manner.
11. The tank shall be tested for water tightness on site after assembly.
12. All septic tanks shall be installed in accordance with the separation distances outlined in **Appendix C, Table C2**.
13. All septic tanks shall be equipped with a tamper resistant lid labeled "DANGER – DO NOT ENTER".
14. All septic tanks shall be equipped with an effluent filter meeting NSF Standard 46.
15. A septic tank manufactured on-site shall be designed by a professional engineer licensed to practice in Prince Edward Island and conform to applicable CSA Standards.

1.3.1 Septic Tank Sizing

Any septic tank is required to meet the following sizing requirements: (**Figure 1.1** - Septic Tank)

1. Septic tanks for dwellings must have a capacity not less than that stated in **Table 1.1**.
2. For larger systems the minimum capacity shall be calculated as follows:

For peak average daily flows up to 6810 L/day:

$$\text{Tank Volume(TV)} = 2 \times \text{Q}$$

Where: Q – peak average daily flow in litres (L/day)
TV – liquid volume of septic tank in litres (L)

The minimum required septic tank size is 3,400 L. Septic tank sizes larger than the required minimum may reduce problems and extend the life of an on-site system.

Septic tank capacity shall be increased by 25 per cent where a garbage grinder is used.

Access to a tank shall be provided over the inlet and outlet for easier service. The dimension of any opening shall meet latest CSA standards.

All septic tanks shall be fitted with a riser located at the outlet of the septic tank.

All outlets of septic tanks shall be equipped with an effluent filter (**Figure 1.2**) sized to manufacturer's recommendations.

The septic tank shall be installed according to the manufacture's recommendations.

Two compartment tanks are required when the daily flow exceeds 4,100 L to reduce solids carry-over to the disposal field. Each compartment shall have an access riser for

purpose of maintenance that extends to the ground surface as outlined in the riser section.

The interconnecting port in the divider should be located approximately one-half way in the liquid depth.

The final compartment should be approximately one-third of the total volume.

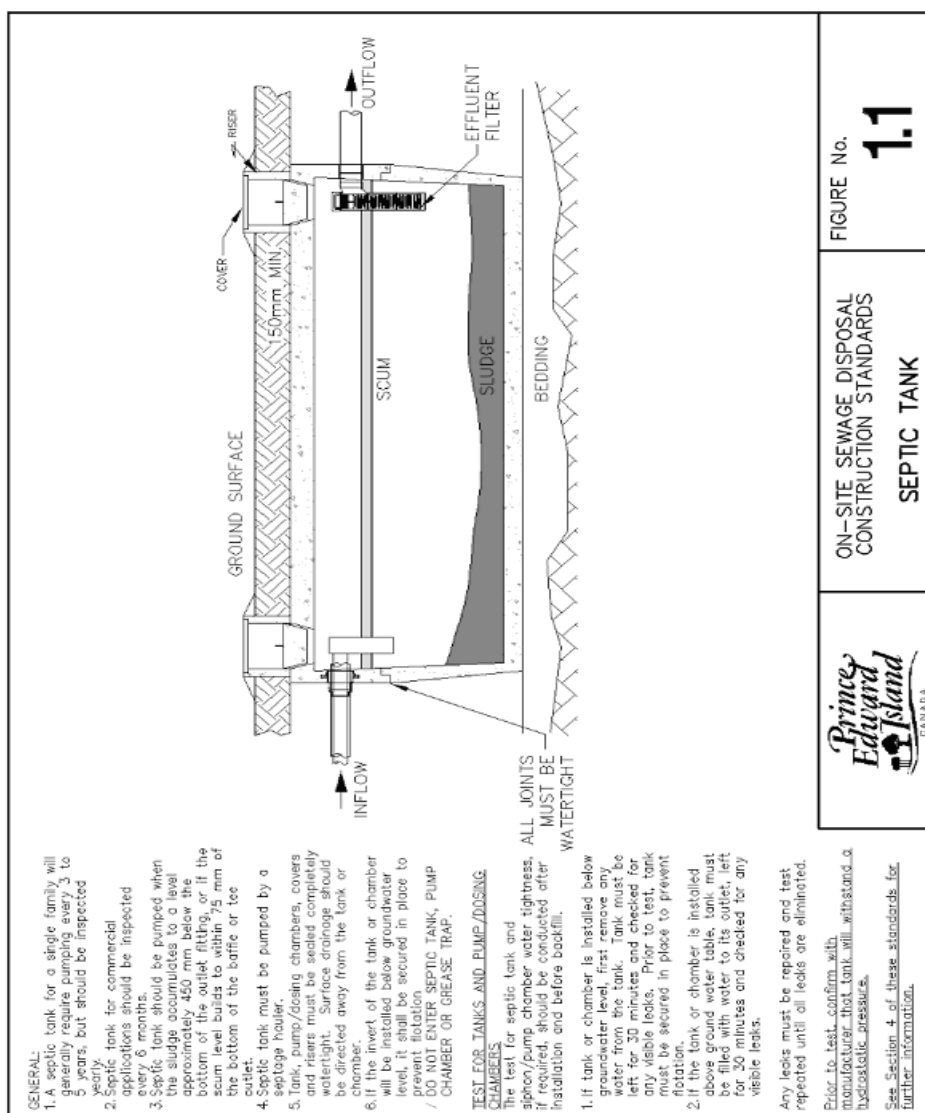

Figure 1.1 Septic Tank

Table 1.1 Minimum Capacity of Septic Tanks for Dwellings

Number of Bedrooms	Minimum Liquid Capacity in litres
Up to 3	3,400
4	4,090
5	4,500

When selecting a tank, the depth of bury must be considered. If it is greater than 600 mm, the tank should be stamped to indicate that it has been designed to withstand burial to the required depth.

1.3.2 Effluent Line

The effluent line, which is the pipe that allows effluent to move from the septic tank to the distribution field, can be fed by a gravity distribution system or a pressure distribution system.

The following are the requirements of each:

1.3.3 Gravity Effluent Line Requirements

1. A gravity line shall be a 100 mm diameter pipe, non-perforated, rigid, smooth bore and watertight and certified to CSA standards. (as for Building Sewers, section 1.2)
2. A gravity line shall have watertight joints.
3. A gravity line shall have a grade not less than one per cent.

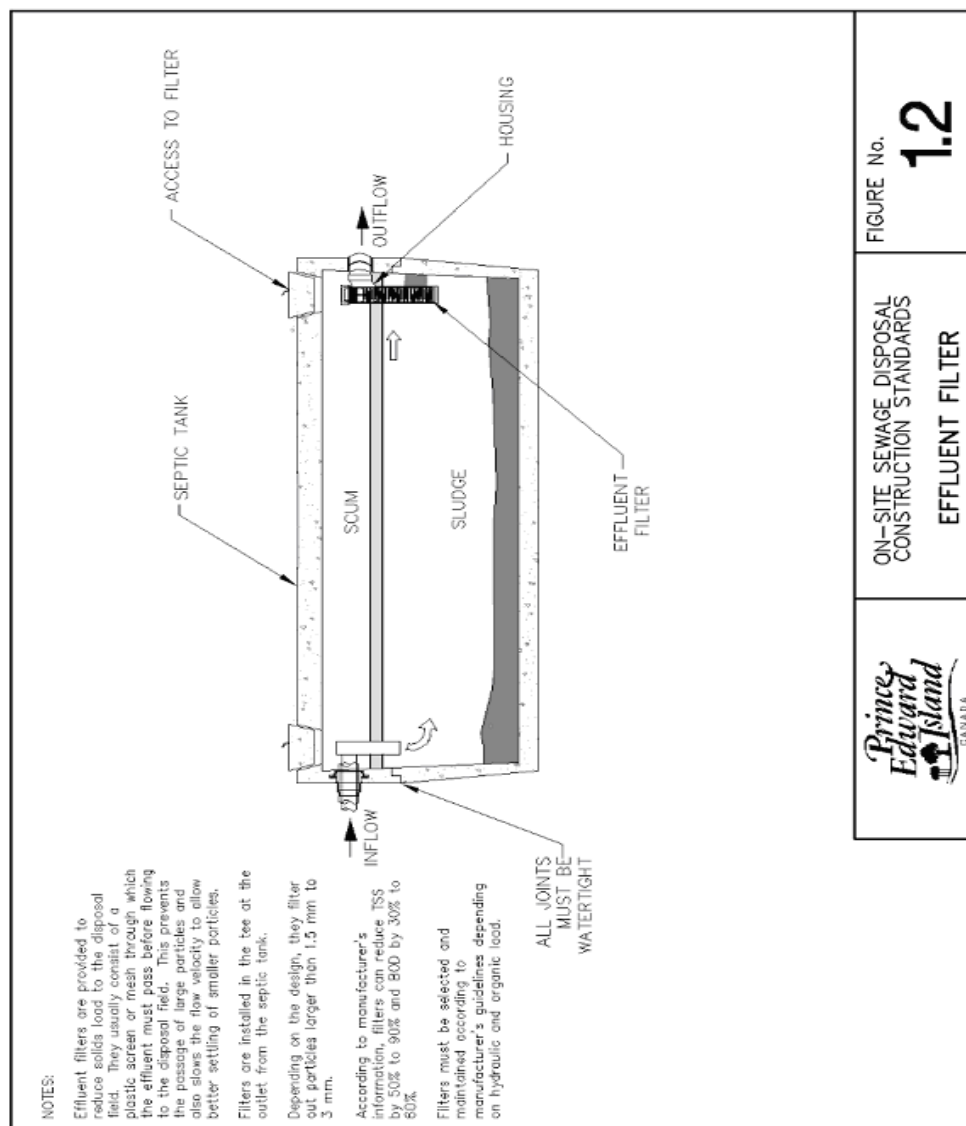

Figure 1.2 Effluent Filter

1.3.4 Pressure Effluent Line Requirements

1. Pressure line shall be a 38 mm min. (1.5 inch) diameter pipe, non-perforated, rigid, smooth bore, watertight and shall be SDR 26 certified piping or equivalent and conform to the most recent CSA specification.
2. The joints of the pressure pipe shall be watertight and installed according to the manufacturer's recommendations.
3. Provide appropriate freezing protection methods such as adequate depth of cover, insulation and/or draining of effluent lines after each pump cycle stops.
4. Pressure line to the tank (if necessary) shall be a minimum of 3 metres from a domestic water well.

FIGURE No.

1.2

ON-SITE SEWAGE DISPOSAL
CONSTRUCTION STANDARDS

EFFLUENT FILTER

Prince
Edward
Island
CANADA

1.3.5 Pressurized System Pipe Requirements

A pressurized system is more effective than a gravity system as it provides both uniform distribution and periodic dosing of the disposal field. The disadvantage of a pressurized system is the higher capital cost and the extra maintenance requirements associated with the pump or dosing chamber. Pressurizing using a pump or dosing chamber is required:

- where an end fed disposal line is longer than 30.5 linear metres
- where the one disposal bed exceeds 152.4 linear metres
- where the natural ground slope is not uniform and a gravity system might concentrate effluent at one or more weak spots in the field
- for any system where the disposal field is at a higher elevation than the septic tank

Where a pump or dosing chamber is required, the solid pipe from the pump or dosing chamber to the disposal field must have a minimum diameter as specified by the pump or siphon manufacturer but shall not be less than 38 mm. Piping within the dosing chamber and extending 1 metre from chamber shall be schedule 40 (in accordance with the most recent CSA standard). All pumped systems shall be connected to the disposal field using a "siphon breaker" as shown in Figure 1.3.

For any system selected to serve a single family home using a pump or dosing chamber, the perforated pipe in the distribution field can be similar to gravity distribution pipe (Subsection 1.3.4) with only a 13 mm hole drilled in the top of the pipe 100 mm from the end cap(s). **In addition the distribution piping must be placed such that there is no slope on the piping in the disposal trench.**

For systems serving more than 6810 L/day (designed by a Professional Engineer), the pipe diameter, and hole spacing must be calculated, based on the system hydraulics, in an effort to provide uniform distribution throughout the disposal field. Maintain a minimum 600 mm of head at the most distant orifice. In a designed system the minimum acceptable pipe diameter is 38 mm. The design shall allow for distribution pipe to drain after the completion of each dose.

1.4 Pump and Dosing Chambers

The pump or dosing chamber discharge capacity must be sized to distribute effluent over the entire disposal field during each dose. This allows utilization of the entire field and minimizes the possibility of breakout of effluent in a localized area. Periodic dosing also allows the infiltrative surface to drain between doses. These cycles of alternate dosing and resting may maintain higher infiltration rates in the clogging mat and thus extend the life of the system.

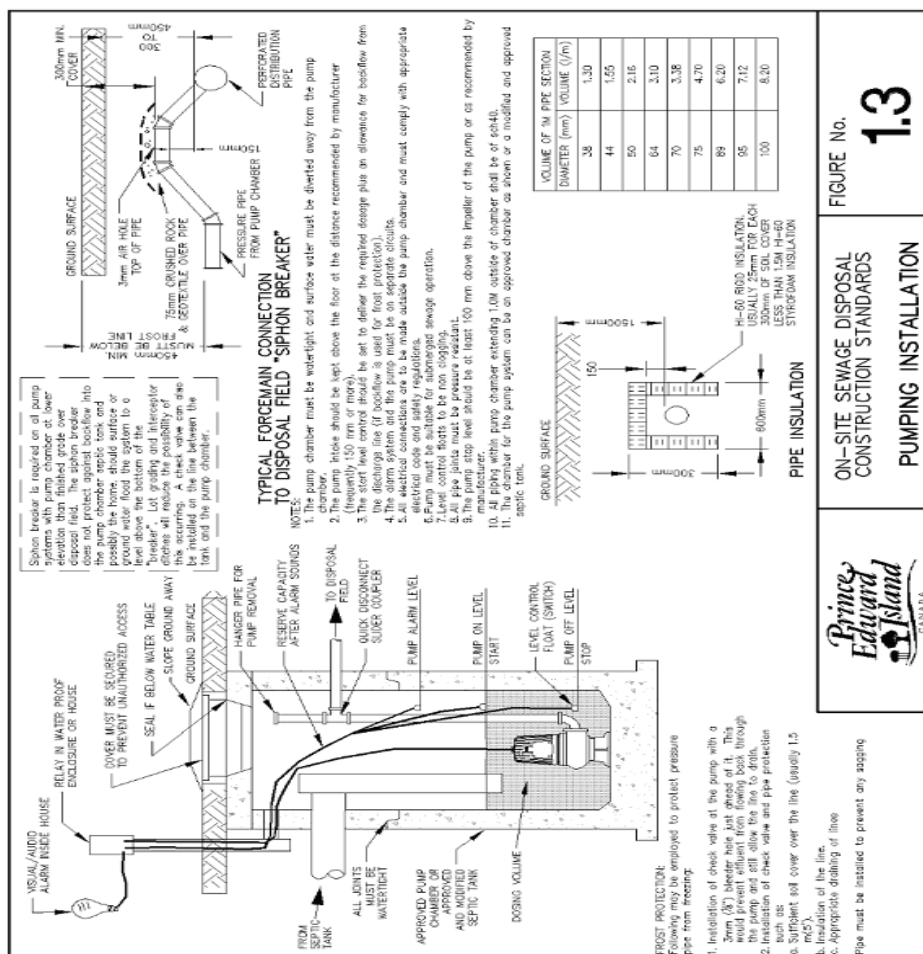

Figure 1.3 Pumping Installation

Where a dosing system is used the minimum dosing frequency is at least two times per day. When a large system is designed, other dosing frequencies may be necessary. The discharge volume must be large enough to flood the entire distribution pipe. Unless the Site Assessor or Engineer specifically selects the pump to be used, it is the installer's responsibility to ensure that the pump has the proper capacity of achieving equal distribution throughout the field.

1.4.1 Dosing Systems

There are two types of dosing systems:

High Pressure Systems provide a calculated residual head (squirt height) throughout the entire distribution network within the disposal field. The piping network continues throughout the entire disposal field and is typically 50 mm in diameter depending upon system type, hydraulics and manufacturer's recommendations. This pipe can be laid on the gravel bed or adequately suspended in a chamber system. These systems shall be designed by a professional engineer licensed to practise on Prince Edward Island.

Low Pressure Systems (Figure 1.4) provide pressure typically through a 50 mm force main (SDR 26 or equivalent) to a point whereby the pipe diameter size is increased to 100 mm. At this point the flow from the pump converts to gravity flow. Typically, the method to convert the high pressure flow to low pressure flow is at the entrance to the disposal header of the system. The 50 mm pressure line is connected to the header at the centre of the header. At this point the diameter of the line changes to 100 mm. This type of pressure installation is more common in residential and smaller commercial installations. When used in conjunction with a chamber system energy dissipation device such as a patio stone should be used at the entrance to each disposal line. Care is required when selecting the pump system to ensure that there is adequate total hydraulic head to overcome the system head (vertical distance between the lowest liquid elevation in the pump tank and the highest point within the system and any friction losses of the pipe, fittings, valves, etc.)

1.4.2 Pumping Chamber Requirements & Sizing

A typical pump chamber is shown in **Figure 1.3** and shall be certified to the latest applicable CSA or ASTM specification.

Requirements for a pump chamber include the following:

1. The chamber shall be equipped with an audible and visible high level alarm, level controls, and other accessories required to assure effective and reliable operation.
2. A riser access shall be installed over the pump(s) for maintenance purposes.
3. The dimension of any opening shall meet CSA requirements and allow easy repair of pumping system.
4. All pumps shall be accessible and set to permit maintenance of pumping system without entering the pumping station.
5. The pump system shall accommodate the automatic start, stop and alarming of system based on the water level of the pump tank.
6. The pump system shall alternate pumps in a multiple pump system.
7. The elevation of the tank shall be such that any horizontal seam is located above the highest seasonal groundwater table or as recommended by the manufacturer.
8. The high water alarm level must be below the level of the horizontal seam. It is recommended that the ***pump chamber should be tested on site after assembly, for water tightness, proper operation and dosing quantities.***

The actual design of a pressure distribution system is based upon hydraulic principles and is beyond the scope of these Standards. In an attempt to simplify selection and standardize equipment requirements for single family homes, the required dosing capacity for siphons and pumps is as shown in **Table 1.2**.

Table 1.2 Dosing Chambers and Pumps/Siphons - Capacity

Flow	Dosing Amount per Discharge Event in Litres	Minimum Pump Chamber Capacity*
1000 L	500 L	1000 L
1350 L	675 L	1350 L
1500 L	750 L	1500 L

* below any horizontal seam

When pumping a considerable distance, the dosing amount and chamber size may have to be increased to compensate for effluent in the pump line returning to the pump chamber after the pump shuts off.

1.4.3 Siphon Breaker

This section specifically addresses pressurized systems for delivery of septic tank effluent to a distribution system in a disposal field. When pumping down slope, the connection is to be made directly into the distribution pipe. If pumping upslope, a siphon breaker is required. The siphon breaker should be located where the pipe from the tank enters the distribution pipe. As well, one 13 mm hole should be placed 150 mm in from each end of the distribution pipe on the top of the pipe (Figure 1.5).

1.4.4 Mechanical-Electrical System

The complete electrical and mechanical system—including pumps, controls, and switches—must be capable of functioning effectively, reliably, and for many years, in a corrosive environment. These systems shall be installed according to the Canadian Electrical Code Requirements.

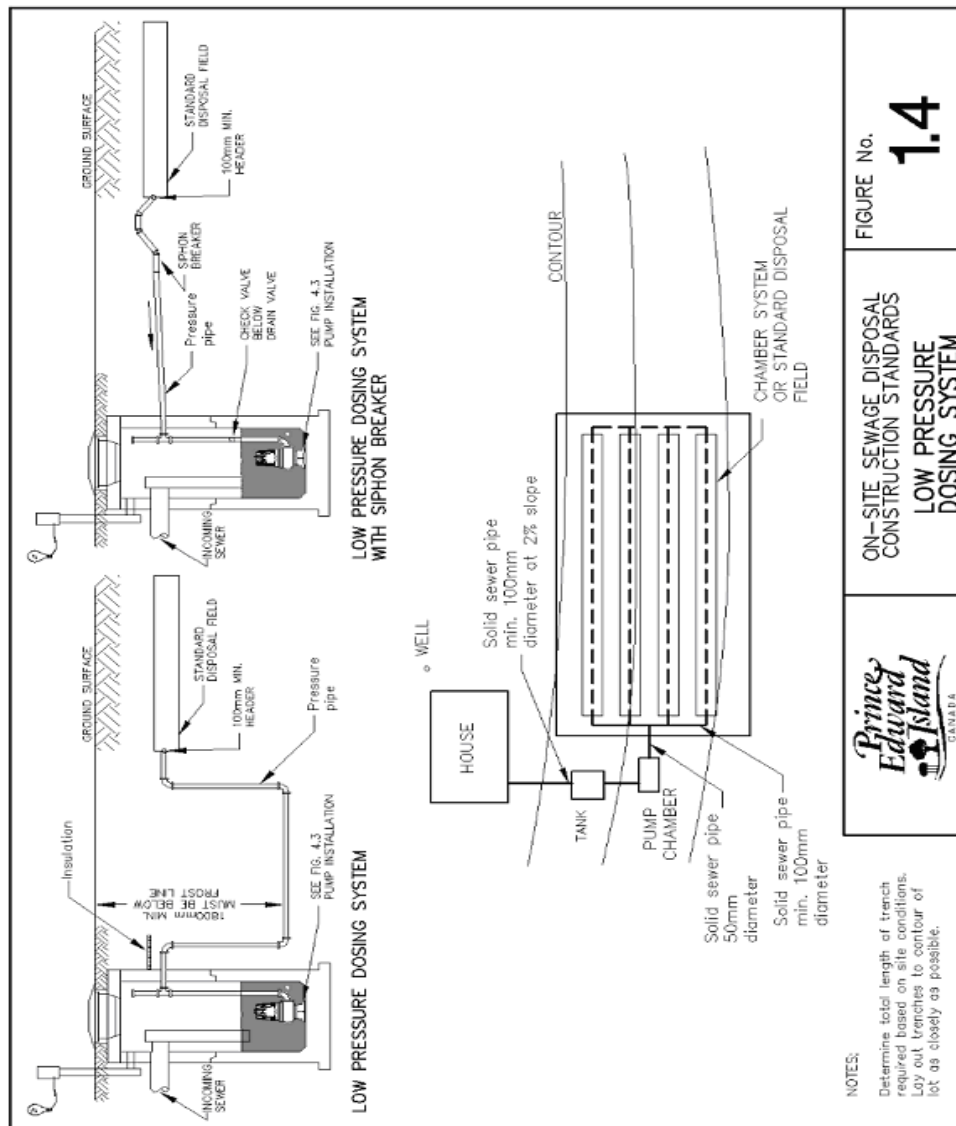

FIGURE No. 1.4
ON-SITE SEWAGE DISPOSAL CONSTRUCTION STANDARDS
LOW PRESSURE DOSING SYSTEM

Figure 1.4 Low Pressure Dosing System

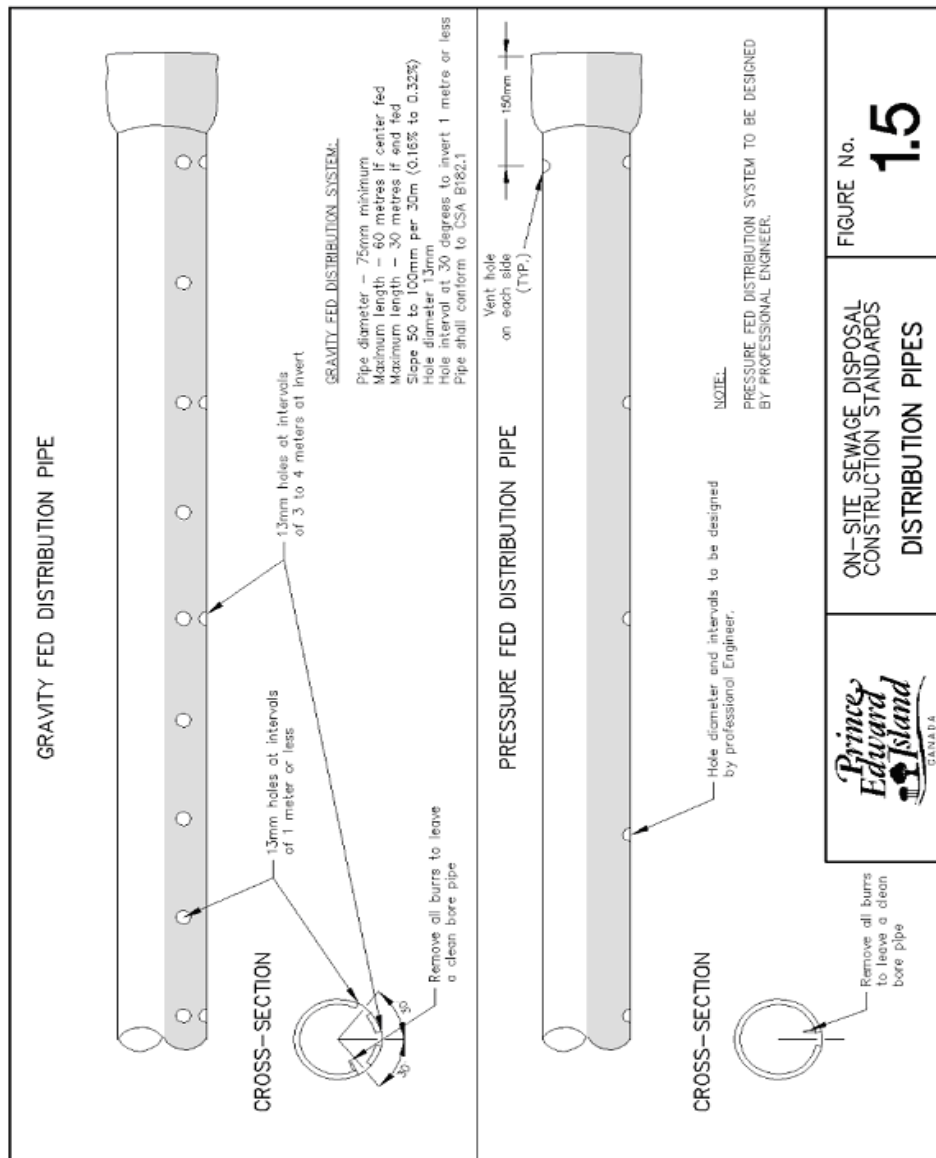

Figure 1.5 Distribution Pipes

1.5 Holding Tanks

Holding tanks (Figure 1.6) are not considered on-site sewage disposal systems. **Once the tank is full the material must be pumped out of the holding tank(s) by a Licensed Pumper and transported to a Wastewater Treatment Plant for final treatment.** Typically, the frequency of the pump out is 5 to 7 days. The operating costs for this type of system can be expensive depending on water use. Water usage can be reduced with the installation of low flow fixtures such as six (6) litre toilets and low flow shower heads. This option should be carefully reviewed prior to installation so that the owner is fully aware of the on going operating cost.

Although the design and installation of a holding tank is similar to that of a septic tank, several additional considerations do exist and are outlined in Table 1.3.

Table 1.3 Holding Tank Considerations

Holding Tank	Considerations
Minimum Size (Residential)	4,540 L
Minimum Size (Commercial)	6,810 L or 2 days storage, whichever is greater
Discharge	No surface discharge allowed
Alarm System	Positioned to allow for ½ day storage after activation
Accessibility	Must be readily accessible to pumping vehicle
Location	Surface water diverted from tank area
Water Use	Water use should be reduced.

The incremental costs of a large tank are minor compared to the cost of pumping over a long period of time. A small sized tank will require more frequent pumping and higher costs whereas a larger tank will require less pumping trips resulting in a lower cost in the long term. Maintenance and operating costs are substantially higher than operation of a regular sewage disposal system. The homeowner must understand that these costs are very

high and that such costs may not be sustainable. Therefore, due to the costs, the use of a holding tank is only recommended as a last resort for on-site sewage treatment. The installation of a holding tank is an option for servicing given that one of the following conditions exists:

- a. in the opinion of the department, no practical alternative for the construction of a disposal field exists;
- b. the sewage holding tank is to be installed for commercial use and, in the opinion of the department there is no practical alternative for the installation of a disposal field.

A licensed septic contractor shall install a holding tank that complies with the manufacturer's recommendations and these Standards.

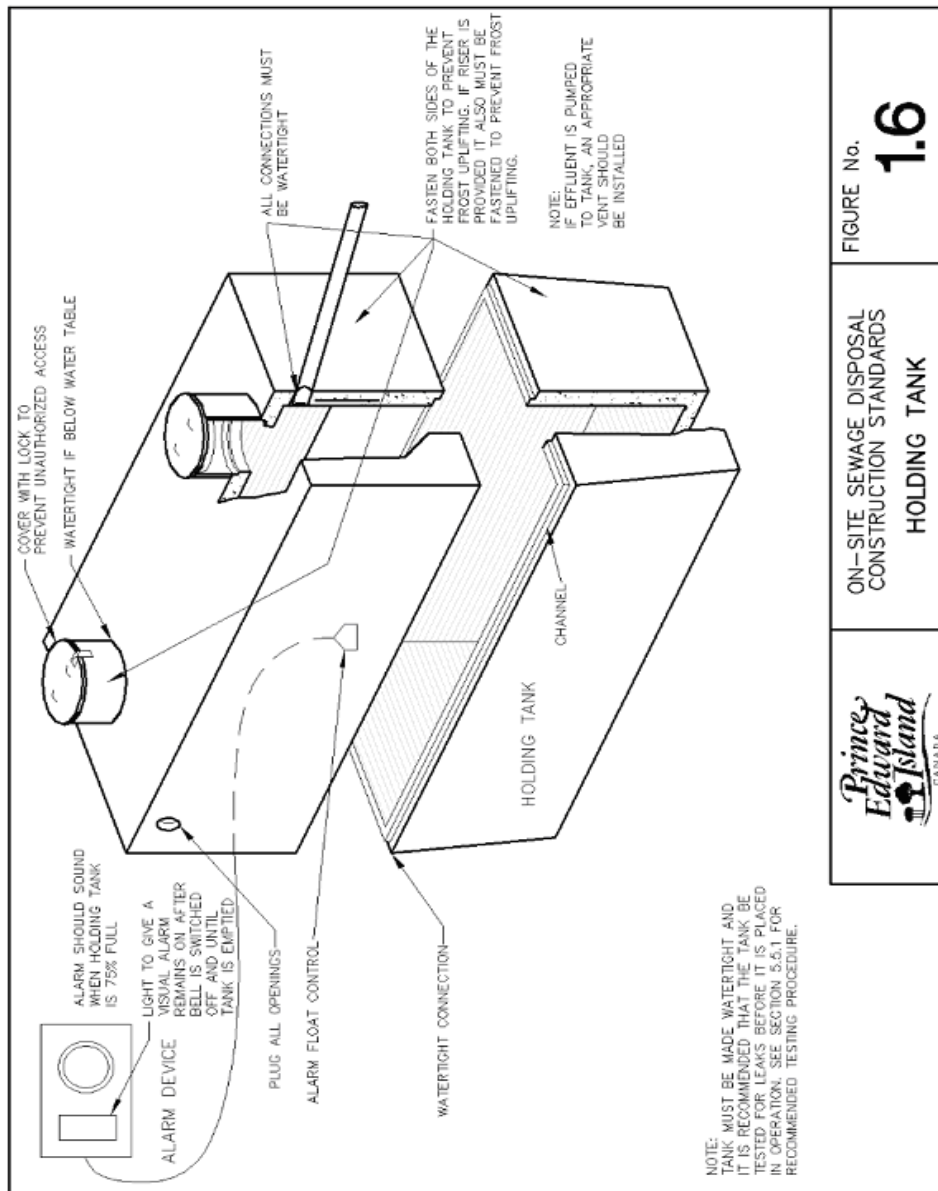

ON-SITE SEWAGE DISPOSAL CONSTRUCTION STANDARDS
HOLDING TANK
 FIGURE No. **1.6**



Figure 1.6 Holding Tank

1.5.1 Requirements for a Holding Tank

1. The requirements for a holding tank (**Figure 1.6**) are as follows:
 - a. Volume is calculated as having twice the maximum expected daily flow as calculated in **Appendix B**.
 - b. Minimum capacity of 4,540 L for residential use and 6,810 L for commercial use.
 - c. Equipped with an audible and visible high level positioned so that it alarms at $\frac{3}{4}$ mark of the liquid capacity of the holding tank.
 - d. Be readily accessible to a pumping truck.
 - e. Be equipped with a riser over the inlet of the holding tank.
 - f. Where a tank is installed in an area where high groundwater levels may occur, the manufacturer shall include instructions to prevent flotation of the tank.
2. The holding tank shall be installed according to the manufacture's recommendations.
3. The proposal for a holding tank should include estimated yearly pump out costs from a Licensed Pumper.
4. A below ground tank shall be constructed of a non-metallic material.
5. A holding tank may be utilized for **above ground** services for an industrial/commercial operation, with the following requirements:
 - a. the tank shall be constructed of non-corrodible material;
 - b. secondary containment shall be supplied (dykes, berms, etc);
 - c. adequate weatherproofing shall be provided to prevent freezing in the tank or lines;
 - d. the tank shall be supplied with adequate hold down and support systems;
 - e. the inlet shall be on the top of the tank and the inlet line shall be self-draining;
 - f. drain valves shall be locked when not in service or security in the form of a fence is provided;
 - g. the tank vent shall be equipped with an odor control device or is extended sufficiently above grade to eliminate odors at ground level;
 - h. the tank shall be installed in accordance with these Standards and the regulations.
6. Holding tanks shall be tested on site after assembly for water tightness.

1.5.2 Riser and Lid

1. A single compartment septic, holding or pump tank shall have a riser section that
 - a. is installed over the outlet opening of the top of the septic tank
 - b. has a watertight seal where it joins the tank
 - c. raises the outlet opening sufficiently to prevent flooding by surface water
 - d. is equipped with a secure tamper resistant locking mechanism with lid
 - e. lid to the riser provides watertight connection
 - f. is labeled clearly "**DANGER – DO NOT ENTER**"
2. A multiple compartment septic, holding or pump tank shall maintain the above requirements and shall have a minimum of one riser section located over each compartment.
3. Refer to **Figure 1.6** for construction details
4. All riser and lid sections shall be installed according to the manufacturer's recommendations.
5. Riser installation procedures shall be submitted by the manufacturer of the septic, holding or pump tanks.

1.6 Interceptors

Interceptors are installed to intercept and divert surface water and groundwater upslope of a disposal field. An interceptor may be a trench filled with gravel, and containing a perforated pipe, or a swale (shallow trench) at the ground surface (**Figure 1.7**). Situations in which interceptors are required, and their locations relative to the ground surface, are defined in this Section.

1.6.1 Interceptor Trench

An interceptor trench may be required or considered in order to address the following situations:

- (1) intercept and divert perched groundwater over a layer of impermeable soil;
- (2) lower a seasonally high groundwater table upslope of a system that is located at lower end of a long slope;
- (3) intercept and divert surface water.

In situation (1) the base of the trench should be set at least 150 mm into any impermeable layer.

In situation (2) the depth of the trench should be a minimum of 150 mm below the bottom of the distribution field. In some cases this could result in an interceptor depth of up to 2 meters or more.

In situation (3) a trench intended to intercept groundwater may also intercept surface water, or a trench (french drain) may be intended specifically to intercept and divert surface water. In the latter case the trench should be at least 300 mm deep.

The interceptor trench should be 0.3 to 0.6 m in width and be filled with gravel. It may contain a perforated pipe with a slope. The trench must be sloped and sod placed where it is practical.

Any interceptor trench must be long enough to divert the intercepted water to a point where it will not enter the disposal system and to where it will freely discharge to the surface, well down slope of the disposal field. It is recommended that the discharge point for the interceptor extend a minimum of 6 metres down slope of the disposal field or buffer. It is recommended that interceptors be located 5 to 10 metres upslope of the distribution field and that they pass no closer than within 5 metres of the end of the disposal field. If these separation distances cannot be achieved, it may be necessary to use impervious fill, such as compacted clay or bentonite, to ensure that surface/ground water does not enter the disposal field or have sewage enter the interceptor.

If the trench is to intercept surface water either the gravel should be carried to within 50 mm of the surface (with no final cover material or sod) to allow surface water to enter the trench, or a swale should be included at the surface. The option of no final cover material may not be practical if there is a danger that sediment from upslope sources may clog the surface of the gravel.

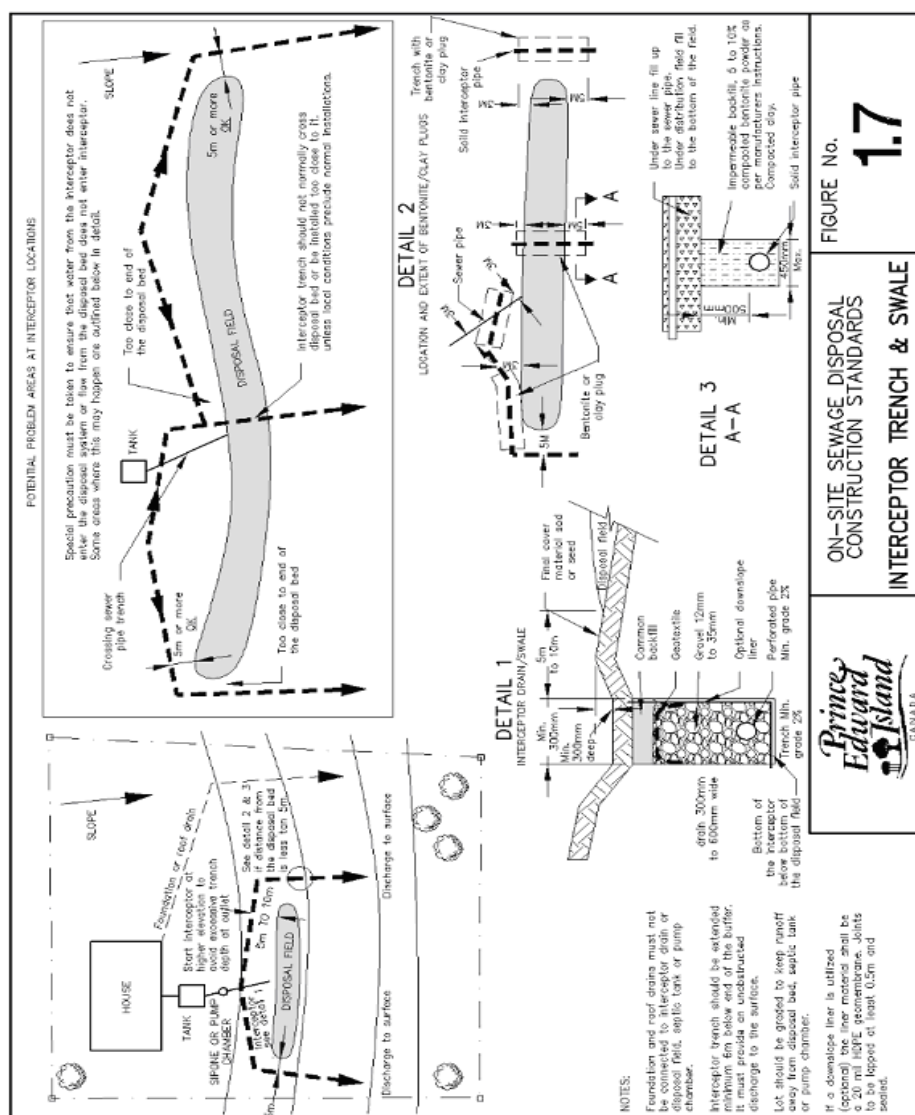

Figure 1.7 Interceptor Trench and Swale

FIGURE NO.

1.7

ON-SITE SEWAGE DISPOSAL
CONSTRUCTION STANDARDS

INTERCEPTOR TRENCH & SWALE

Prince
Edward
Island

CANADA

Normally, the interceptor will drain past either or both ends of the disposal pipe, but for very long contour systems, an interceptor trench may be required to cross the disposal system at intervals. Where this crossing occurs the trench shall be constructed of solid pipe and should be laid a minimum of 500 mm below the bottom of the distribution trench (**Figure 1.7**). This drain line must be sealed with impermeable fill such as compacted clay or bentonite, for a minimum of 3 metres upslope and 5 metres down slope of the distribution field. Roof water must not be connected to the perforated pipe in an interceptor trench, but may be carried in a solid pipe in the same trench.

In some cases such as highly permeable soils or high surface water flow, it may be advisable to place a liner on the down slope and bottom of the interceptor trench. If a liner is utilized, it must be placed along the bottom of the interceptor trench and up the vertical face of the down slope side of the trench; it must not be placed on the upslope side of the trench (**Figure 1.7**). The liner shall be a 20 mil HDPE geomembrane with all seams overlapped a minimum of 0.5 metres with an appropriate sealant between the overlap.

1.6.2 Interceptor Swale

A swale is intended to intercept surface water. It may be constructed alone, or at the surface of an interceptor trench.

A swale should be at least 0.3 m deep and 0.6 m wide, and sodded with sloping sides to permit mowing.

The length of any swale must be enough to divert the intercepted water to a point where it will not enter the disposal system and be sloped down and beyond the system.

1.7 Grease Chambers

Grease chambers usually are not necessary on kitchen waste lines from residential development. However, in some commercial/institutional applications such as restaurants, school cafeterias and kitchens at summer camps, grease chambers **are required**. For the purpose of these Standards, a grease chamber is a chamber where grease floats to the surface while the cleaner water underneath is discharged to the septic tank. If this grease is not removed prior to entering the septic tank, large quantities may accumulate in the sewer and may block the building sewer or the effluent line to the disposal field, or the disposal field itself.

The small grease traps found on some commercial/institutional kitchen drains are not considered adequate to protect the disposal system. The liquid volume of the grease chamber must be large enough to permit the water to cool allowing the grease to separate and rise to the top of the grease tank.

The volume of a grease chamber shall be calculated using the following equation:
For Restaurants:

$$V_{\text{grease}} = D * (HR/2) * GL * ST * LF$$

Where: D - number of seats in dining area
 HR - number of hours open per day
 GL - gallons of wastewater per meal (2 or more)
 ST - Storage capacity (normally 2)
 LF - Loading factor depending on restaurant location
 1.25 - central locations
 1.0 - recreation areas
 0.5 to 0.8 - other locations

For Cafeterias or Institutional kitchens:

$$V_{\text{grease}} = M * GL * ST * LF$$

Where: M - Total number of meals served per day
 GL - Gallons of wastewater per meal (2 or more)
 ST - Storage capacity (normally 2)
 LF - Loading factor
 1.0 with dishwasher
 0.5 without dishwasher

For all but large establishments, a converted 2,725 litre septic tank would have adequate capacity to serve as a grease chamber and may be the most economical solution even if it has more than the minimum required capacity. To convert a septic tank to a grease chamber, a tee can be installed on the outlet and extended to be 300 mm above the tank bottom (**Figure 1.8**).

To allow for proper maintenance, clean out covers shall be extended to finished grade. The cover shall be watertight and secured to prevent unauthorized entry. To minimize problems with grease solidifying in the sewer line the chamber should be located close to the building but not closer than 1.5 m, no more than 10 m from the fixture being served, and on undisturbed earth or compacted fill material..

1.8 Final Cover Material

The complete on-site sewage disposal system shall be covered with a layer of soils that will promote the growth of vegetation over the system.

The material used to cover on-site sewage disposal systems is referred to as final cover material and will consist of: "Imported, manufactured or site prepared material consisting of

friable sandy silt or silty sand with a 4 to 25% organic matter content. The material must be free of debris, vegetation, and roots, with no stones greater than 25 mm in size. The material used shall be capable of supporting grass or similar vegetation.

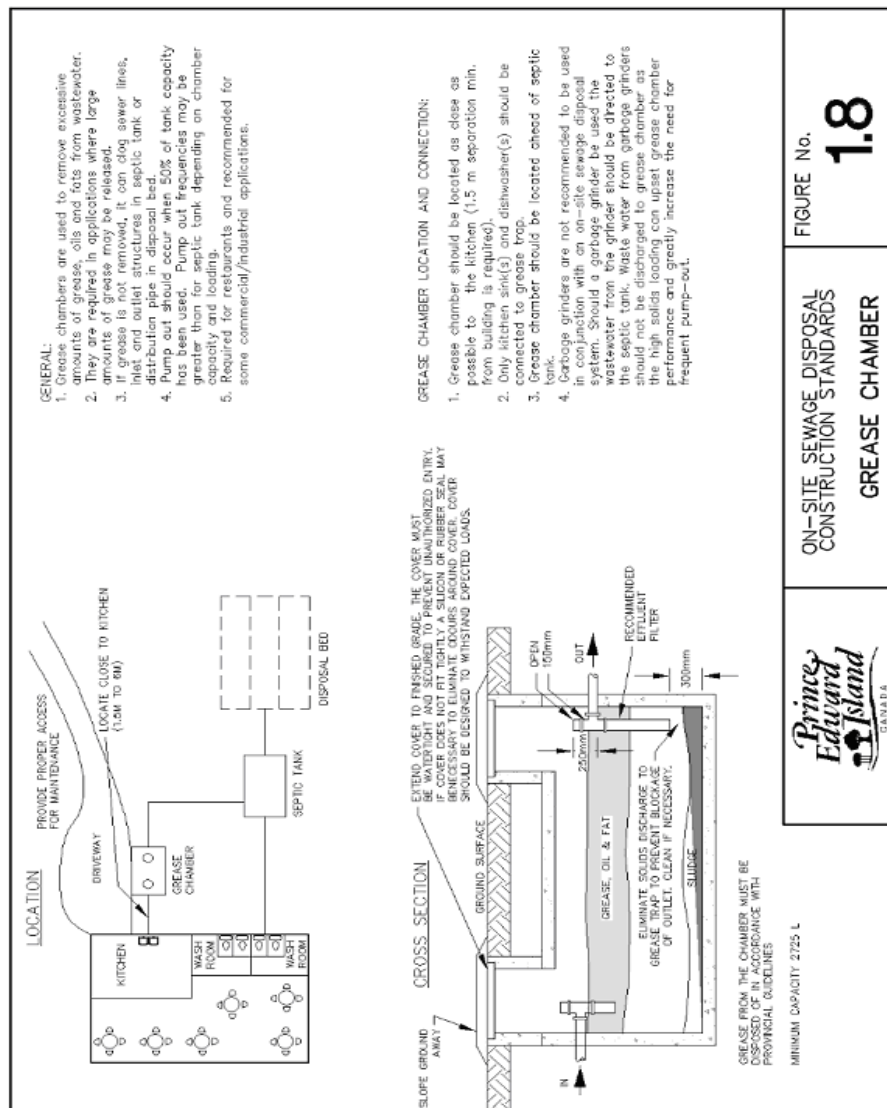

FIGURE No.
1.8

ON-SITE SEWAGE DISPOSAL
CONSTRUCTION STANDARDS
GREASE CHAMBER

Prince
Edward
Island
CANADA

Figure 1.8 Grease Chamber

1.9 Approved Products

Products for use in on-site sewage disposal systems shall be CSA approved. The use of products/materials other than what has been described in these Standards may be considered by the Minister. In these cases, the use of such a product or material must be done in accordance with the Minister's approval recognizing it as a product for use in an on-site sewage disposal system.

1.10 Disposal Fields Selection & Layout

1.10.1 Introduction

Most or all septic tank effluent will eventually reach the ground water table, directly or by travel in bedrock or very permeable soils. If the effluent is not adequately treated, drinking water and surface water may become contaminated. It is therefore required that there is well draining soil underneath the disposal field to ensure effluent is treated prior to recharging ground water. The roles of the disposal fields are to uniformly distribute the effluent into the soil profile below the system ensuring that the hydraulic capacity of the soil is not exceeded, and to provide treatment of the effluent leaving the system. This treatment will ensure the protection of groundwater and surface water resulting in the protection of public health and the environment. For the usual circumstances when a system is to be installed on a Category I, II or III lot the Regulations require a minimum of 600 mm of separation between the bottom of the trench and bedrock, maximum water table or soil with unacceptably high permeability. **Please note:** For systems installed on a Category IV lot, the reader is referred to the depths prescribed in Appendix D, (Category IV) and not those shown in this section or some of the sketches in the document. The separation distance under the system can be achieved with the addition of Good Quality Fill

where suitable permeable soils are not present. All on-site sewage disposal systems shall meet the required minimum setbacks provided in **Appendix C**.

The on-site disposal fields discussed in this section which can be selected by a Site Assessor, a Licensed Septic Contractor/Assessor and a Professional Engineer are:

- Multiple Trench
- Alternative Multiple Trench
- Gravelless Disposal Systems
- Contour Trench C1, Raised C1, C2 & C3

The on-site disposal field shall not be located:

- where, at any time, the maximum water table is less than 0.6 m (2 ft) below the ground surface
- in soil which does not meet the definition of permeable soil;
- in any area which may be subject to flooding either by a natural body of water or by surface water runoff;
- under a roadway;
- under a paved area;
- under an area used by motor vehicles;
- under an area used intensively by livestock;
- less than 6.1 m (20 ft) from a foundation;
- less than 3.0 m (10 ft) from a parcel boundary or an embankment;
- less than 15.2 m (50 ft) from any well; or
- Less than 15.2 m (50 ft) from a natural boundary of a body of water.

See **Appendix C, Table C2** for more details.

1.10.2 Disposal Field Sizing

Disposal field sizing not listed in the tables outlined in **Appendix D** shall be determined using the following formula and calculations:

$$\text{Drainage pipe length (m)} = \frac{Q (L/d) \times SLR (m^2/1000L/d) / 1000}{CA (m^2/m)}$$

1) Calculate the wastewater flow (**Q**)

2) Calculate septic tank volume (size)

3) Calculate the length of the disposal field system according to the following:

1) Choose the soil loading rate (**SLR**)

i) For Category I & Category III (permeable soil 2-4 feet)

conditions choose:

- 36 m²/1000L/day for multiple trench disposal field
- 36 m²/1000L/day for leaching chamber disposal field
- 31 m²/1000L/day for contour trench disposal field

ii) For Category II, Category III (permeable soil 1-2 feet) &

Category IV conditions choose:

- 41 m²/1000L/day for multiple trench disposal field
- 41 m²/1000L/day for leaching chamber disposal field
- 36 m²/1000L/day for contour trench disposal field

2) Choose the contact area / linear foot of trench (**CA**)

i) For multiple trench system the CA is 0.6 (m²/m)

ii) For a leaching chamber system the CA is 1.2 (m²/m)

iii) For a contour trench disposal field the CA is

- for a 0.9 m wide trench is 1.1 (m²/m)
- for a 1.2 m wide trench is 1.4 (m²/m)
- for a 1.5 m wide trench is 1.7 (m²/m)
- for a 1.8 m wide trench is 2.0 (m²/m)

Where:

Flow (Q) is the design flow referenced from **Appendix B** or as determined by actual measured readings;

Soil Loading Rate (SLR) is the disposal area required for each one thousand litres per day of wastewater generated and is expressed as square metres per 1,000 litres per day ($m^2/1000L/day$);

Contact Area (CA) is the minimum square metres per linear metre of gravel/soil interface on the bottom of the trenches in the disposal field. The contact area is expressed as square metres per linear metre (m^2/m).

1.10.3 Multiple Trench

A multiple trench system has been the conventional method of treating and disposing of effluent. It consists of a series of disposal trenches oriented along the contour connected by a level solid header pipe and footer pipe. In **Figure 1.9**, a solid header and a perforated (optional) footer pipe are joined by a number of perforated laterals. The trenches should be oriented with the greatest dimension across the slope of the lot. The header pipe and footer pipes are laid level in an attempt to ensure equal flow distribution to the laterals.

The width of the trench is a minimum of 600 mm. Wider trenches can be used where required. Lateral trenches shall be installed 2.0 metres apart centre to centre, where site conditions allow. Trenches can be closer together if special care is taken to ensure excavated material from one trench does not fall into the next trench. A minimum 1.5 metre separation distance, centre to centre is required for all disposal fields, however, at all times a minimum of 900 mm is maintained between the trench walls..

Selection of a Multiple Trench

Once it has been determined that conditions allow the installation of a multiple trench type system, the minimum total length of trench can be selected from the table in **Appendix D**.

The dimensions of a multiple trench system may be selected as follows:

1. Determine the average daily flow in L/day from the tables in **Appendix B**.
2. From the test pit information determine soil type, depth of permeable soil and total soil depth to bedrock or water table.
3. From the tables found in **Appendix D**, determine if soil depths allow the selection of a trench type field and if so determine the depth of trench allowed.
4. If conditions allow the selection of a trench type system, select the length of trenches for the soil type from the tables in **Appendix D**.
5. Refer to **Figure 1.9** for typical layout of a multiple trench system.

Layout of a Multiple Trench

To use a multiple trench type disposal field the following conditions must be met:

1. There is at least 600 mm permeable soil on the lot for a Category I disposal field size (**Appendix D**).
2. There is at least 300 mm permeable soil on the lot for a Category II disposal field size (**Appendix D**).
3. There is at least 300 mm permeable soil on the lot for a Category III shallow bedrock disposal field size (**Appendix D**).
4. There is at least 1200 mm of Good Quality Fill (GQF) on a lot for Category IV disposal field size, where there is less than 300mm permeable soil (**Appendix D**). Also, a 3 meter buffer must be maintained around the perimeter of the field bed.
5. There is at least 300 mm permeable soil under the disposal trench.
6. There is at least 600 mm separation between the bottom of the trench and the maximum water table elevation, bedrock or soil with unacceptably high permeability.

Where these conditions cannot be met, the selection of another type of disposal field may be required.

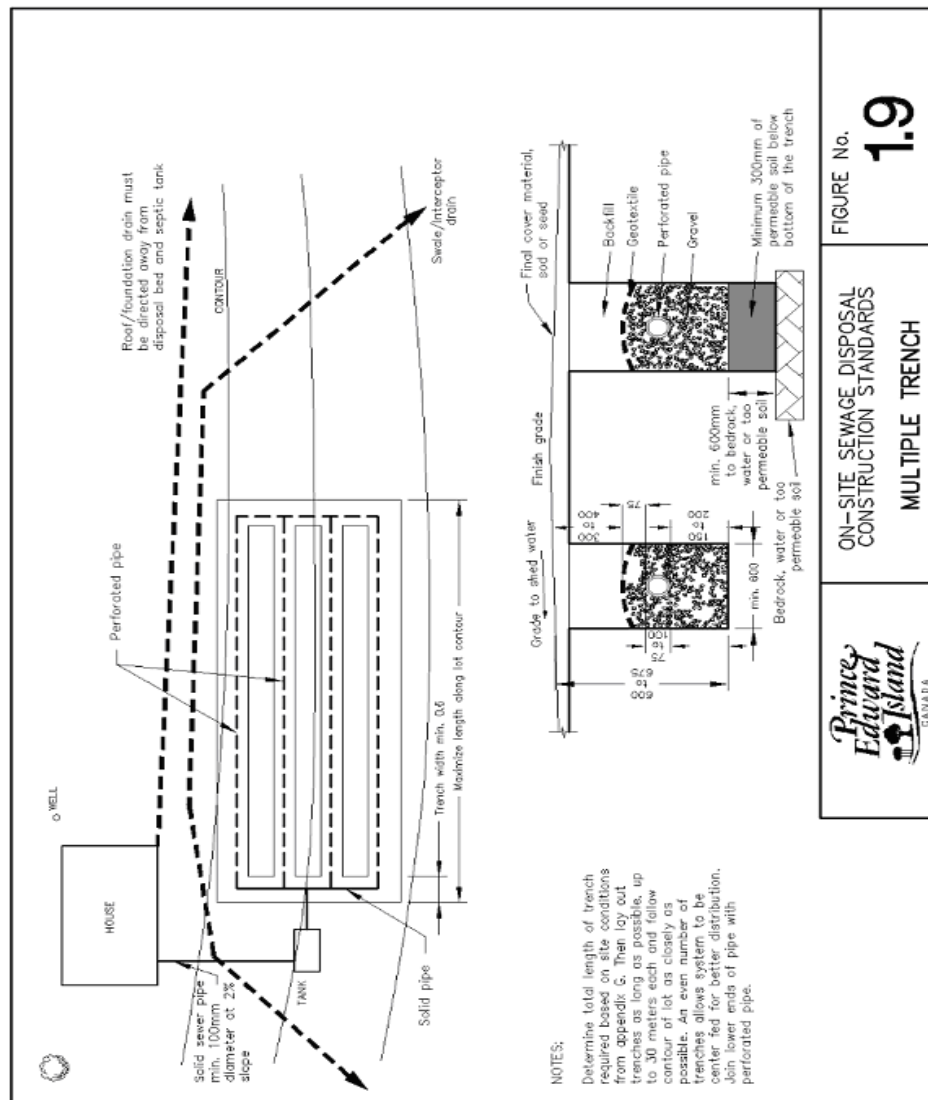

Figure 1.9 Multiple Trench

1.10.4 Alternative Multiple Trench

An alternative multiple trench consists of a series of disposal trenches oriented perpendicular to the contour of the land connected by a level solid header pipe and footer pipe in **Figure 1.10**. A solid header and a perforated footer pipe (optional) are joined by a number of perforated laterals. The minimum width of the trenches will be 600 mm. Laterals to be installed a minimum of 4 m apart where pipe conditions allow.

Selection of an Alternative Multiple Trench

To use an alternative multiple trench type disposal field, the following conditions must be met:

1. Determine the average daily flow in L/day from the tables in **Appendix B**.
2. From the test pit information determine soil type, depth of permeable soil and total soil depth to bedrock or water table.
3. From the tables found in **Appendix D**, determine if soil depths allow the selection of a trench type field and if so determine the depth of trench allowed.
4. If conditions allow the selection of a trench type system, select the length of trenches for the soil type from the tables in **Appendix D**.
5. Refer to **Figure 1.10** for typical layout of an alternative multiple trench system.

Layout of an Alternative Multiple Trench

To use an alternative multiple trench type disposal field the following conditions must be met:

1. There is at least 600 mm permeable soil on the lot for a Category I disposal field size (**Appendix D**).
2. There is at least 300 mm permeable soil on the lot for a Category II disposal field size (**Appendix D**).
3. There is at least 300 mm permeable soil on the lot for a Category III shallow bedrock disposal field size (**Appendix D**).
4. There is at least 1200 mm of Good Quality Fill (GQF) on a lot for Category IV disposal field size, where there is less than 300mm permeable soil (**Appendix D**).
Also, a 3 meter buffer must be maintained around the perimeter of the field bed.
5. There is at least 300 mm permeable soil under the disposal trench.
6. There is at least 600 mm separation between the bottom of the trench and the maximum water table elevation, bedrock or soil with unacceptably high permeability.

1.10.5 Gravelless Disposal Systems

Gravelless disposal systems offer alternatives to traditional pipe and gravel distribution systems. The use of gravelless systems technology can be advantageous in areas where gravel is difficult to place or may not be readily available. Systems such as chambers and other synthetic aggregate systems must meet appropriate standards for sewage disposal systems distribution and must meet specifications outlined in **this Appendix**. Gravelless systems may consist of open-bottomed chambers, fabric-wrapped pipe, and pipe wrapped in synthetic materials such as expanded polystyrene (EPS) foam chips. A number of proprietary gravelless systems have been approved for use in specific jurisdictions throughout North America, including Prince Edward Island.

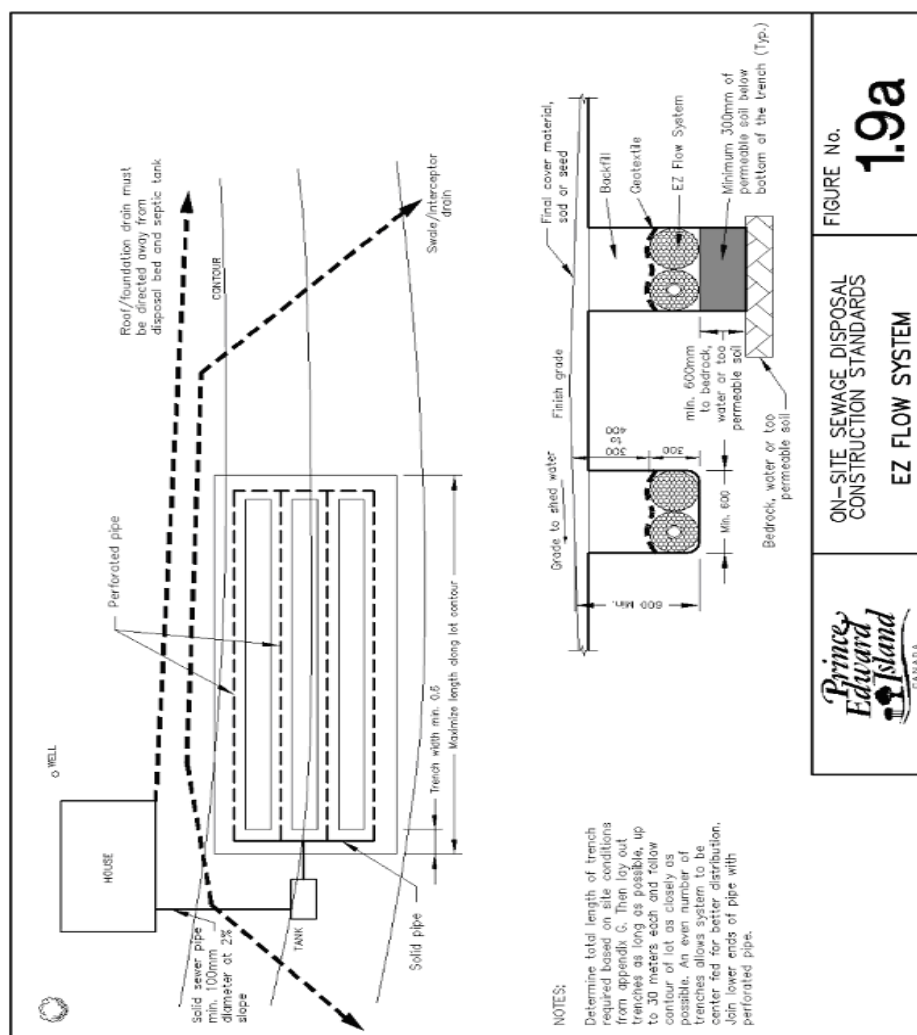

FIGURE No.

1.9a

ON-SITE SEWAGE DISPOSAL
CONSTRUCTION STANDARDS

EZ FLOW SYSTEM



Figure 1.9a EZflow System (Multiple Trench)

Gravelless technologies, like the leaching chamber system, shall be selected and laid out according to these standards and the manufacturer's installation recommendations must be approved for distribution by the Minister. Where applicable, system sizing for these systems has been adjusted and approved by the Minister, allowing for increased contact area in these systems. In the leaching chambers systems up to 50% reduction is permitted. With the *EZ flow* system a reduction of up to 33% is permitted. The *EZ flow* system (**Figure 1.9a**) is only permitted for use in a multiple trench design.

A typical design layout of a gravelless system like the leaching chamber system have been approved for use in PEI since 1996 and two options for installation approved by the department include a Shallow In-ground System and an At-grade System (see **Figure 1.11**).

The **in-ground** system is used when the following conditions can be maintained:

1. System can be placed within 600 mm of surface;
2. Depth of permeable soil below the system is minimum 300 mm;
3. 600 mm separation to groundwater, bedrock, or "too permeable" soil.
4. **Appendix D** provides the lengths required for the various lot categories.

The **at-grade** system is used when the conditions required for the in-ground system cannot be met. The at-grade system is required to be backfilled with Good Quality Fill (GQF).

The **at-grade** system is used when the following conditions can be maintained:

1. System is placed at grade;
2. Depth of permeable soil below the system is minimum 300 mm;
3. Soil under the system is scarified;
4. 600 mm separation to groundwater, bedrock, or "too permeable" soil.
5. **Appendix D** provides the lengths required for the various lot categories.

Layout of Chamber System (Multiple Trench)

The trenches shall be excavated parallel to the ground contour. The lines of the chambers shall be of equal length. A minimum depth of 300 mm of permeable soil below the bottom of any trench of the disposal field is required. The minimum distance of the walls of adjacent trenches shall be 900 mm and the minimum spacing between the chambers shall be 1800 mm centre to centre. The bottom of each trench shall be level and of equal elevation. Each line of chambers shall be fed from a header via tees and the downstream end of each line shall be connected to a bottom header.

For gravity fed systems, the inlet pipe shall extend through the end plate and terminate on an adequate splash plate (concrete patio stone) or an energy dissipation device. This is required for both high and low pressure distribution systems.

Where the total length of leaching chambers in a multiple trench configuration exceeds 150 m, they shall be constructed in two or more separate disposal fields connected to the septic tank by using, a) a sewage pumping station or b) a siphon chamber.

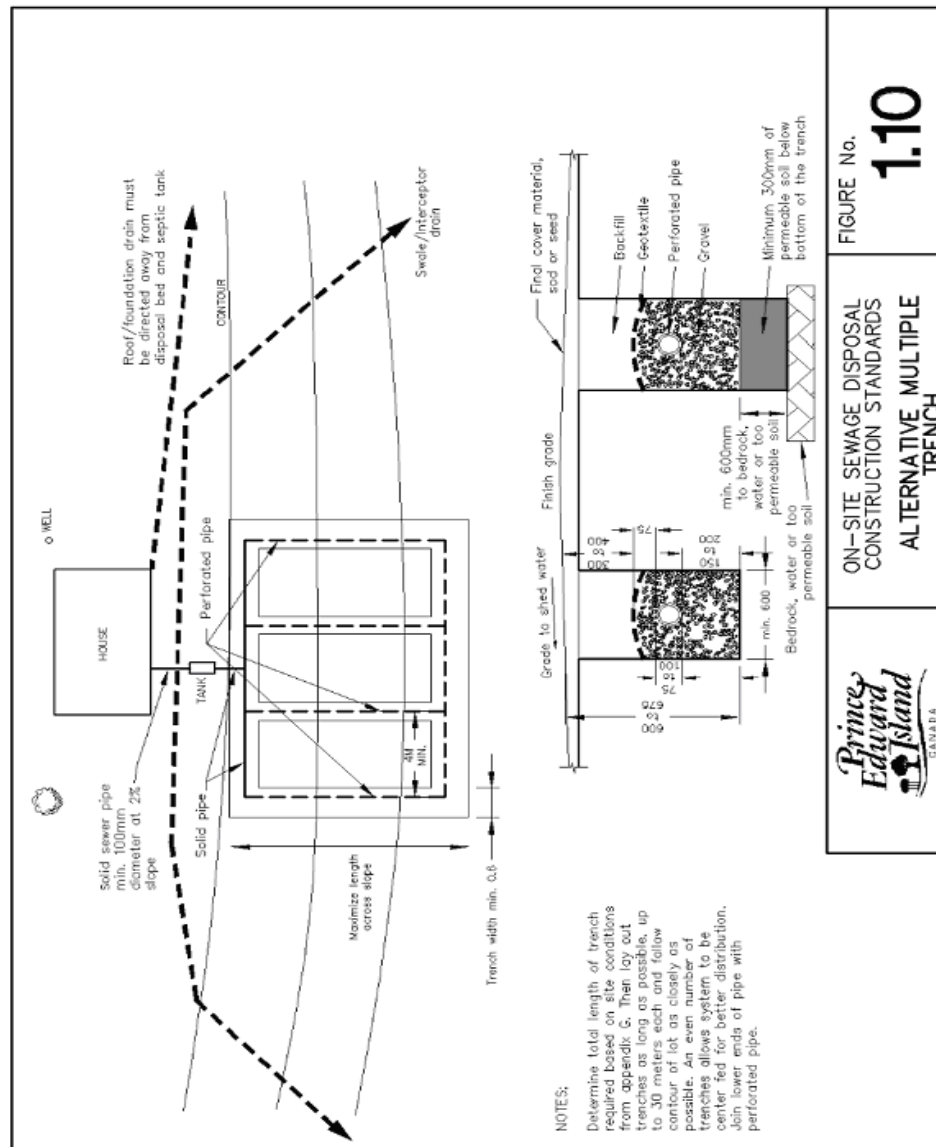

Figure 1.10 Alternative Multiple Trench

Layout of EZ Flow System (Multiple Trench)

For use in raised bed applications, the *EZflow* 1202 is a bundle of 2 pieces each of 300mm in diameter by 3.0 meters long. The *EZflow* 1202 is designed for use in trench applications.

Installation Instructions

The instructions for installation of *EZflow* products are given below. In cases where linear footage required is not in multiples of 10, installer may (a) reduce the product to needed length and refasten netting to the pipe or, (b) use an additional 10 feet of product to exceed the required trench length.

Disposal Field Use

The *EZflow* 1202H, systems can be used in disposal fields as follows:

1. The *EZflow*1202H system is to be installed side by side, in a 600 mm wide trench, one cylindrical bundle shall be of solid aggregate fill (without pipe) and the other cylindrical bundle (with pipe) shall be of aggregate and drainage tile.
2. Disposal field trenches shall follow the ground surface contours so that variations in trench depth will be minimized.
3. The minimum clearance distances required shall be met. Determine the permitted location and excavate the trenches.
4. Construction of trenches shall comply with these Standards. Trench wall and bottom are to be raked or scarified to loosen soil.
5. Remove plastic *EZflow* stretch wrap prior to placing bundles in the trench(s). Remove any stretch wrap in the trench before system is covered.

6. Place first EZflow bundle(s) in the trench. The next bundle(s) with pipe are joined end to end with approved internal pipe couplings. Connect and place additional EPS bundles with pipe in trenches until the required linear footage has been obtained and cap the ends with approved caps.
7. If installing an EZflow product that does not contain a pre-inserted geotextile, then a geotextile barrier cover shall be placed over the top of these products prior to backfilling. The barrier material must meet the requirements of these Standards.
8. These products shall be covered with a minimum of 300 - 400 mm of backfill.
9. The trench top shall be shaped or mounded to ensure surface water runoff.

Where the total length of the field bed in a multiple trench configuration exceeds 150 m, the field bed shall be constructed in two or more separate disposal fields connected to the septic tank by using, a) a sewage pumping station or b) a siphon chamber. The design layout of an EZflow system is similar to a standard multiple trench system as shown in **Figure 1.9a**.

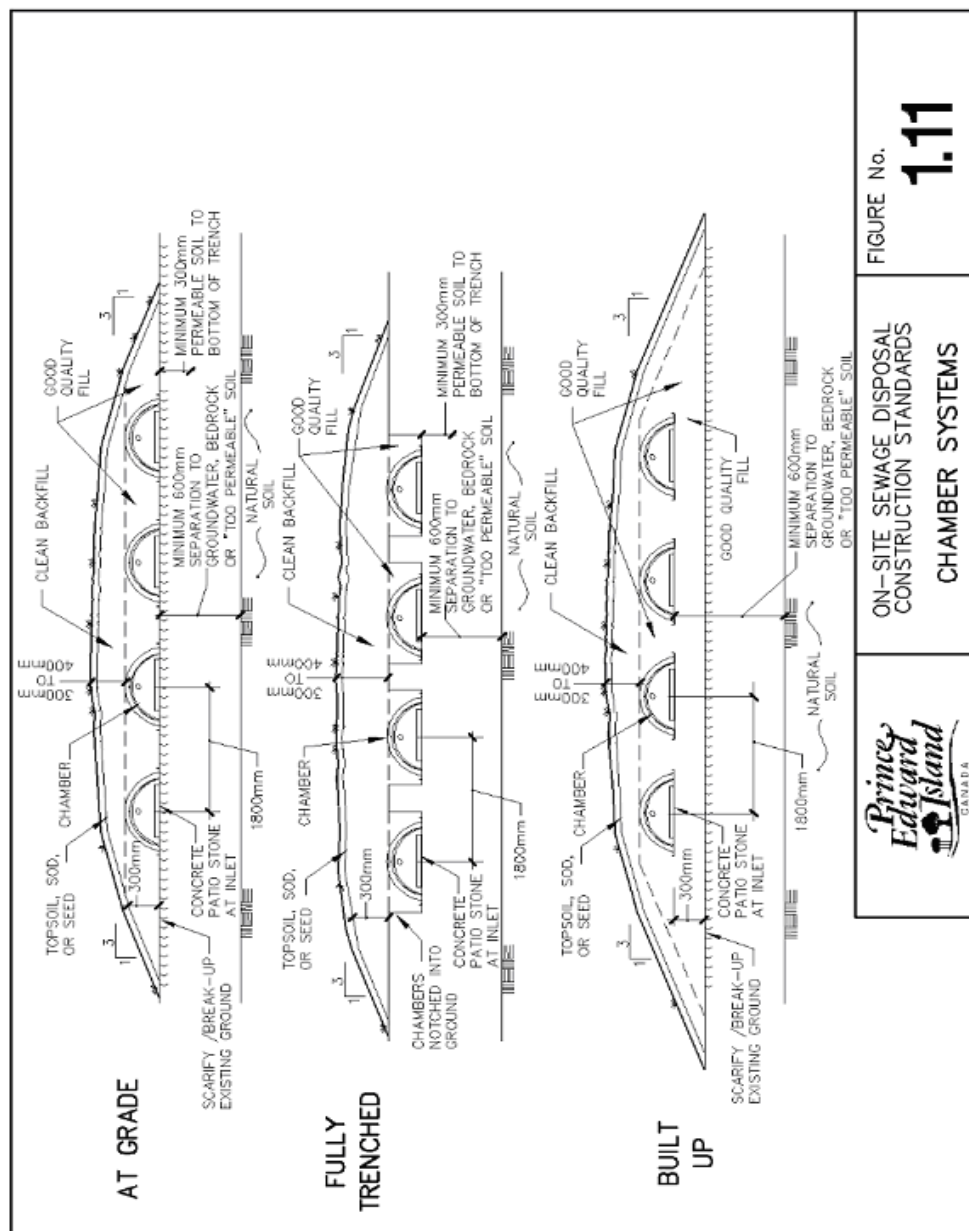

FIGURE No.
1.11

ON-SITE SEWAGE DISPOSAL
CONSTRUCTION STANDARDS
CHAMBER SYSTEMS



Figure 1.11 Chamber Systems

1.10.6 Contour Trench C1 and Raised C1

A contour trench is a conventional disposal field constructed along the contour line. Details of a C1 contour trench are shown in **Figure 1.12**.

A C1 trench may be used:

- where the surface slope at the location of the trench is at least 5 per cent
- where the width of the lot will allow for the length of the selected C1 trench

A C1 trench is fed by a gravity distribution system, except where a pressure system is required where the distribution field is at a higher elevation than the septic tank.

An interceptor trench or swale may be necessary, to intercept and divert surface or ground water if a perched water table exists, or if the system is located at the lower end of a long slope.

Refer to **Section 1.6** for more information on interceptor trench or swale.

Depth Limitations for a C1 Contour Trench

Figures 1.12 and **1.13** illustrate two possible C1 contour installations.

It is important that the C1 trench excavation does not penetrate the soils with unacceptably low permeability and that there is a minimum of 300 mm of permeable soil under the disposal field. It should also be noted that the draining of a perched water table may allow for the increase of an effective soil depth.

As illustrated in the raised C1 cross section (**Figure 1.13**), clearance to water table, bedrock and soils with unacceptably high permeability can be increased if the trench is raised by not more than 300 mm. This trench will require an earth cover as illustrated and an interceptor trench and/or swale.

Selecting a C1 Contour Trench

The length of a C1 trench is determined using the table in **Appendix D**. The table used will depend on the average daily flow leaving the dwelling and the depth of permeable soil.

Other factors include the amount of room for a contour system on the property and the total depth of soil above water table, bedrock, or soil of high permeability.

The length of a C1 trench will range between 30 m and 60 m. If a C1 system cannot be selected due to limiting soil conditions, then a C2 or C3 system may be considered with the addition of Good Quality Fill (GQF).

Criteria for selecting a C1 system:

- a) Determine the number of bedrooms and low flow fixture option.
- b) Determine the surface slope at the proposed location of the disposal field. If the slope is less than 5 per cent or greater than 30 per cent, a C1 system cannot be used.

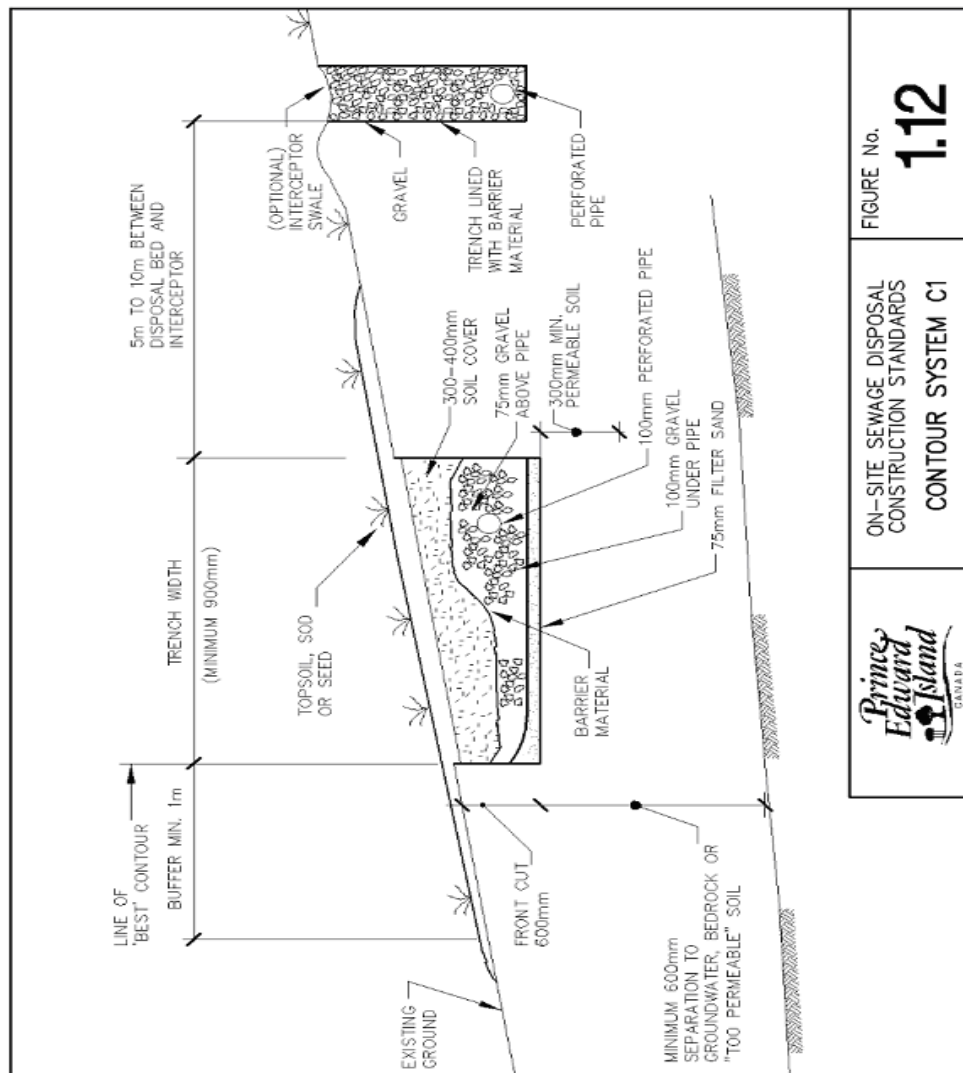

Figure 1.12 Contour System C1

- c) Determine the category of the soils in the area of proposed disposal field. If the total depth of permeable soil is less than 600 mm a C1 system cannot be used.
- d) Determine the maximum depth to water table, bedrock, soil with unacceptably high permeability. If this value is less than 1.2 m, then a C1 system cannot be used.
- e) Determine the lot category.
- f) Once the lot category, number of bedrooms and system type are determined, refer to **Appendix D** to determine the trench length and width.
- g) The cross section dimensions of the disposal field shall be those shown in **Figures 1.12 and 1.13**

Layout of a C1 Trench

Figures 1.12 and 1.13 illustrated the layouts of fully trenched C1 and raised C1 trenches.

A trench is excavated along the contour to the required width and depth. The trench bottom is perfectly level throughout its length and width. The bottom of the trench and the down slope side walls are then raked. After raking, filter sand is deposited in the bottom of the trench to a depth of 75 mm, with excess filter sand raked to the down slope side of the trench. The sand is placed as shown in **Figure 1.12 & 1.13**. Once the sand is in place a minimum of 100 mm of gravel will be placed. The amount of crushed rock at the tee will exceed 100 mm because the pipe will be sloped toward the end of the system.

1.10.7 Contour Trench C2

A C2 contour trench may provide an alternative in situations where a C1 trench cannot be used. **Figure 1.14** illustrates the layout of a standard C2 trench.

A C2 trench is similar to a C1 trench in that effluent leaving the trench is expected to move laterally in the soil below the organic surface layer. In a standard C2 contour trench a layer of Good Quality Fill, above the ground surface, enables saturation of the existing soil to the natural ground surface preventing possible breakout.

Use of C2 systems is limited to locations where the surface slope at the location of the trench is at least 5 per cent. If the slope is less than 5 per cent, a multiple trench or chamber system must be used. The exact selection is dependent on the site.

A modified C3 trench, constructed according to **Figure 1.16**, should be used instead of a C2 trench where uneven surfaced lots or boulder fields are encountered.

A C2 trench is fed by a gravity distribution system, except that a pressure system is required where:

- the length from the tee feeding the system, to the end of the distribution pipe, exceeds 23 m
- the natural slope is not constant and a gravity system may tend to concentrate effluent in one part of the system
- The distribution pipe is at a higher elevation than the septic tank.

Where groundwater, bedrock, or soil with unacceptably high permeability occurs under a C2 trench, a 600-mm vertical separation must be maintained between the bottom of the disposal field trench and the above conditions. This may require the use of a C3, rather than a standard C2, to ensure that this 600 mm separation is met.

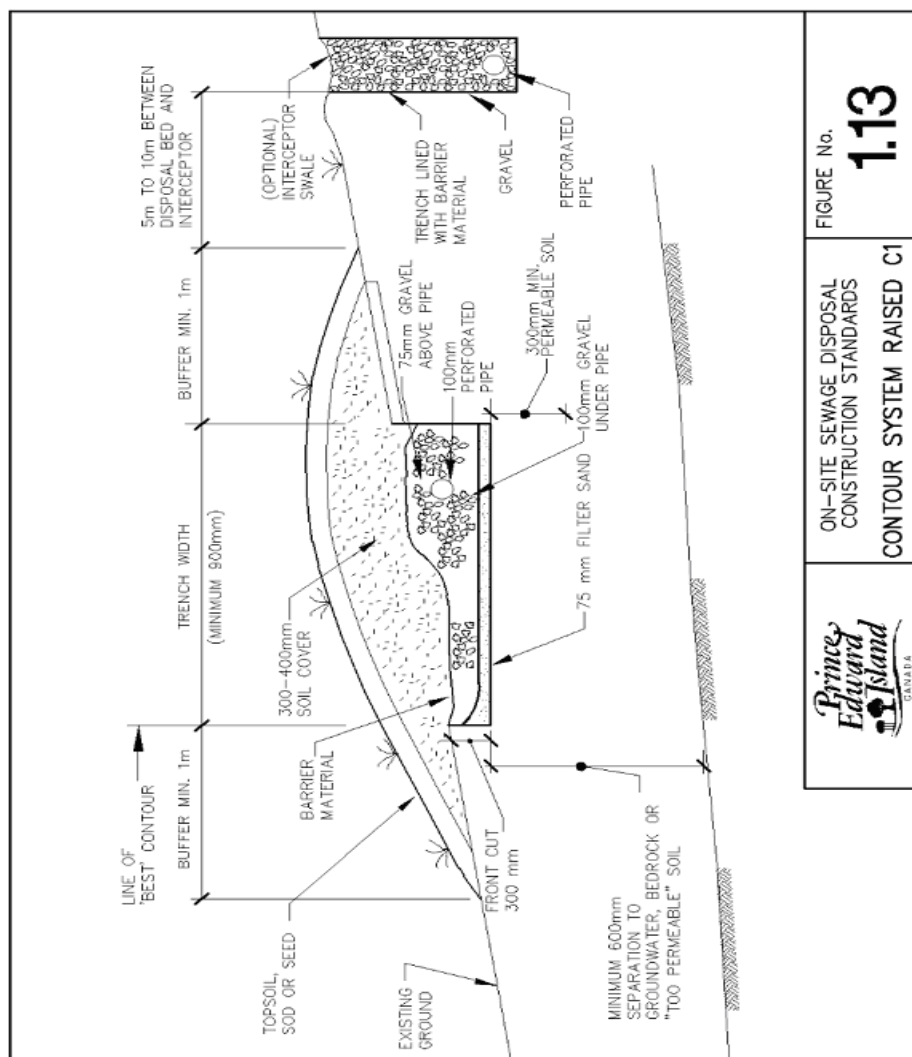

Figure 1.13 Contour System Raised C1

Selection of a C2 Trench

The length of a C2 trench is determined using the table in **Appendix D**. The table used will depend on the average daily flow leaving the dwelling and the depth of permeable soil. The amount of area for a contour system on the property, and the total depth of soil above water table, bedrock, or soil of unacceptably high permeability must be taken into consideration.

The length of a C2 trench will range between 30 m and 60 m. If a C2 system cannot be selected due to limiting soil conditions, then a C3 trench system may be considered.

Criteria for selecting a C2 system:

- a. Determine the number of bedrooms and low flow fixture option.
- b. Determine the surface slope at the proposed location of the disposal field. If the slope is less than 5 per cent or greater than 30 per cent, a C2 contour trench cannot be used.
- c. Determine the depth(s) of permeable soil. If the total depth of permeable soil is less than 300 mm a C2 system cannot be used.
- d. Determine the depth to water table, bedrock or soil with unacceptably high permeability. If this value is less than 1.2 m, then a C2 system cannot be used.
- e. Determine the category of lot.
- f. Once the lot category, number of bedrooms and system type are determined, refer to **Appendix D** to determine the trench width and length.

The cross section dimensions of the disposal field shall be those shown in **Figure 1.14**.

Layout of Standard C2 Trench

Figure 1.14 illustrates the layout of a standard C2 trench. The toe of the trench is excavated along the contour to a depth of 175 mm into the permeable soil.

The trench is then excavated to the necessary width while keeping the bottom of the trench perfectly level throughout its length and width. The trench bottom and down slope side walls are raked. The depth of the trench from the upslope side will be greater than the depth at the toe.

A 75 mm layer of filter sand is deposited in the bottom of the trench and excess filter sand is raked to the down slope side of the trench.

A minimum 125 mm depth of crushed rock is placed on top of the filter sand. This will ensure that the distribution pipe is raised so that its invert is at or above the ground elevation at the down slope lip of the trench. The amount of crushed rock at the tee will exceed 125 mm because the pipe will be sloped toward the end of the trench.

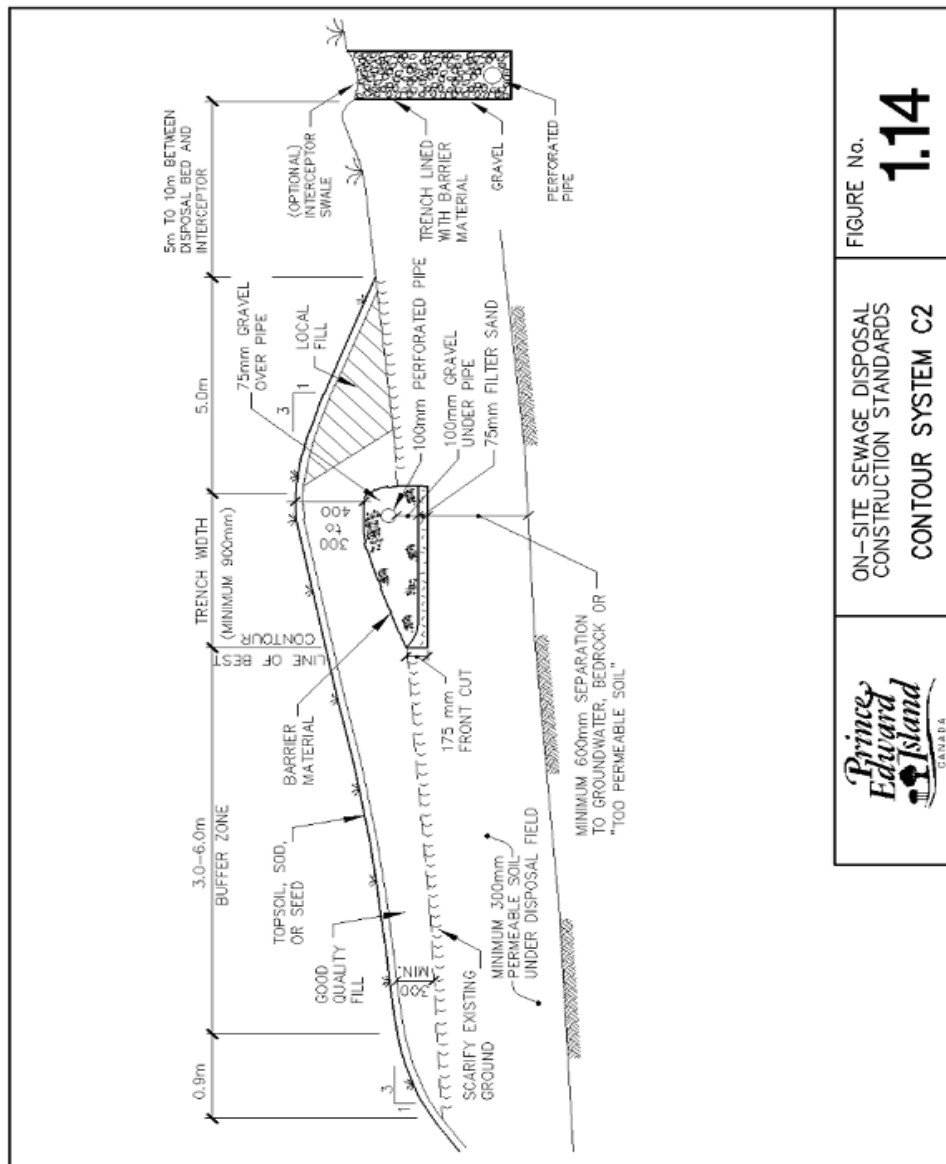

FIGURE No. **1.14**
ON-SITE SEWAGE DISPOSAL CONSTRUCTION STANDARDS
CONTOUR SYSTEM C2



Figure 1.14 Contour System C2

1.10.8 Contour Trench C3

A C3 trench is shown in **Figure 1.15**. This trench consists of a distribution pipe and rock filled trench constructed entirely in good quality fill. The Good Quality Fill (GQF) and trench must follow the site contour.

- additional depth of good quality fill is required to protect groundwater
- site conditions—uneven sites including boulder fields, or undulating wooded areas—require a modified C3 system, **Figure 1.16**, instead of a C2 trench
- the surface slope is at least 5%

Effluent leaving the trench in a C3 is expected to move vertically through the Good Quality Fill (GQF) until it reaches the natural soil under the fill. Effluent will then move vertically into the natural soil if the permeability allows, or down slope through the good quality fill where the permeability of the natural material is inadequate to allow the effluent to enter the soil.

Selection of a C3 Trench

Where ground water, rock or soil with unacceptably high permeability occur under the C3 trench, the depth of good quality fill must be enough to provide a 600 mm vertical separation between the bottom of the distribution trench and the ground water, rock or soil with unacceptably high permeability. Under these conditions, select a C3 as shown in **Figure 1.15** with a depth of good quality fill adequate to give the 600 mm separation, but not less than 600 mm.

The dimensions of a C3 system can be determined as follows:

- a. Determine the number of bedrooms and low flow fixture option.
- b. Determine the ground surface slope at the location of the trench and confirm that is greater than 5% and less than 30%.
- c. Based on the flow determined in (a) and the slope determined in (b), the length of the C3 and the type of good quality fill required is selected from **Appendix D**.
- d. If the distance from the bottom of the trench to ground water, bedrock, or soil with unacceptably high permeability is a factor, select the depth of good quality fill required to give the minimum 1 m separation. Where separation to ground water, bedrock, or soil with unacceptably high permeability is not a concern select a depth of 600 mm good quality fill under the trench.
- e. Select other dimensions of the system from **Figures 1.15 and 1.16**.

Where a C3 type system is installed on a lot with very little permeable soil over solid bedrock or soil with unacceptably low permeability and effluent is expected to be obvious at the down slope toe of the sand buffer it is recommended that a 150 mm layer of sand plus final cover material and sod be extended beyond the buffer. The down slope width of this extra buffer is determined on a site by site basis but should extend at least 7 m or to the point where there is adequate permeable soil or root zone to absorb the effluent.

Layout of a C3 Trench

The required dimensions of the buffers for a C3 trench are shown on **Figures 1.15 and 1.16**. Fill used for the buffer upslope of the trench may be Good Quality Fill or clean fill material. Good Quality Fill is required for down slope and end buffers. The down slope edge of the rock trench in the C3 is laid out to follow the contour of the site.

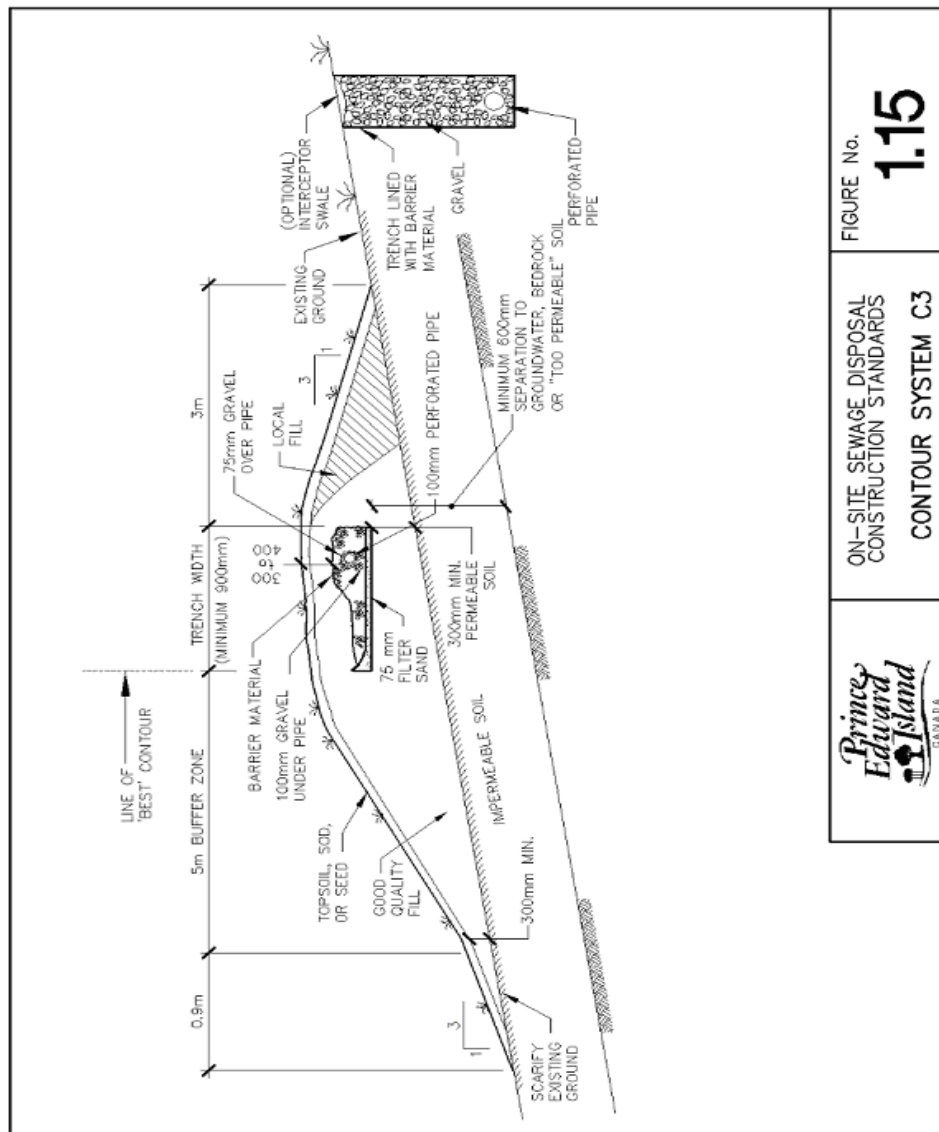



FIGURE No. **1.15**
 ON-SITE SEWAGE DISPOSAL CONSTRUCTION STANDARDS
 CONTOUR SYSTEM C3

Figure 1.15 Contour System C3

1.12.2 Specifications

Typically, in PEI the GQF added to the site is a reasonably uniform sand or sandy gravel with a small portion of silt/clay. The recommended sieve specifications for suitable sand are given in **Table 1.4** and should be used for all systems that require fill material under and around the disposal field and in the buffer areas of the disposal field.

The recommended Good Quality Fill Specifications are listed in **Table 1.4**. Contractors should strive to meet or exceed these recommendations. However, sieve analysis results can vary due to sampling. For this reason, the department will accept up to 15% silt & clay passing at the No. 200 sieve.

Table 1.4 – Good Quality Fill (GQF)

Sieve	Effective Particle Size (mm)	Percent Passing by weight (%)
1 in	25	95 to 100
3/8 in	9.5	70 to 100
No. 200	0.075	2.5 to 10

1.12.3 Contractor's Responsibility

The Licensed Septic Contractor has the ultimate obligation to ensure that the disposal field is installed in material that is suitable and meet the requirements of these standards even though the material may be purchased and installed by another Fill Contractor. It is recommended that the Licensed Septic Contractor inform the Fill Contractor clearly of the fill requirements.

1.13 Buffers

The down slope side of the contour trench may need to be extended due to limited permeable soils on site. If desired, a 150 mm layer of Good Quality Fill (GQF) could be extended 5 meter down slope of the standard 5.9 meter buffer.

APPENDIX B Flow Tables

- The individual on-site sewage disposal system shall be designed and constructed to adequately treat and dispose of the expected maximum flow of sewage.
- The disposal system must be designed to receive all sewage from the building or structure except cooling water, roof, foundation or surface drains or backwash from water treatment devices, unless otherwise approved by the Department of Environment, Labour and Justice. Backwash from water treatment devices add an extra hydraulic load and may create additional concerns depending on the specific treatment technology. Discharge of this backwash to an on-site sewage disposal system is only recommended if the system has been specifically designed by a professional engineer to accept the specific discharge.
- The minimum design sewage flow from any residential structure or dwelling, shall be 900 L/day. When it is anticipated that the sewage flows from the dwelling or structure will exceed the 900 L/day minimum, it is recommended that the sewage flows, as indicated in the following **Table B1**, be utilized:

Table B1 Residential Flows		
Number of Bedrooms	W/Standard Water Closets (Litres)	Low Flow Water Closets (Litres)
2 bedrooms or less	900	720
3 bedrooms	1,400	1,100
4 bedrooms	1,900	1,500
Each additional bedroom	450	350

(For residential applications where 6 litre toilets are installed, a 20 percent reduction in design flow may be applied).

4. The minimum design sewage flow from any multi unit residential structure or dwelling such as, apartments, condominiums, cottages, hotels, etc., shall be 900 L/day. When it is anticipated that the sewage flows from the dwelling or structure will exceed the 900 L/day minimum, it is recommended that the sewage flows as indicated in the following **Table B2** be utilized:

Table B2 Multi Unit Residential Flows		
Unit Type	Average Daily Flow (L/Day)	
	Standard Water Closets	Low Flow Water Closets
For each 1 bedroom unit	900	720
For each additional 1 bedroom unit	450	350
For each 2 bedroom unit	900	720
For each 3 bedroom unit	1,400	1,100
For each 4 bedroom unit	1,900	1,500

5. Industrial wastewater shall not be discharged into on-site sewage disposal systems designed for sanitary sewage disposal unless prior approval is obtained from the Department of the Environment Labour and Justice. Special designs or pre-treatment may be required for industrial waste-water.
6. All restaurants or other establishments involved in food preparation activities shall install external grease tanks.
7. The design sewage flows from other residential, commercial, industrial and institutional buildings or structures should be based on the design wastewater flows prescribed in **Table B3** of this appendix. The minimum design flow from other residential, commercial, industrial and institutional buildings or structures shall be 900 L/day. The designer for these types of systems may want to consider the characteristics of the waste water in the process of design.
8. Where actual metered flow data indicating maximum daily flows are available, such flow data may be substituted for the sewage flows listed in this appendix, under the following conditions:
- The minimum design flow for residential, commercial, industrial and institutional buildings or structures is 900 L/day.
 - They should cover the most recent two (2) week peak period of operation.
 - A 20 to 50 per cent increase factor should be used in the design flow to accommodate potential future flow increases, occasional peaks, etc.
 - Flow meter data, from the facility shall be submitted by the Engineer or site assessor at time of submission, also include information regarding actual occupancy or production volume when unit flows are calculated.
9. A reduction in the design flows may be allowed by the Department of Environment, Labour and Justice when permanent low-volume devices are to be installed in the proposed building or structure.
10. Design flows in this **Appendix B** are recommended minimal design flows and if evidence of larger flows exist or are expected, the larger flows should be used.

In many cases the tables provide several flow rates for the same/similar activity (examples: church halls, restaurants, etc) and the system designer must decide which of the flows provided in the tables is most representative for the specific design. If there is a question related to which flow rate is most appropriate the Department of Environment, Labour and Justice will have the final decision.

**Table B3
Design Wastewater Flows**

Facility	Unit of Measure	Maximum Design Flow (Litres/day)
<i>Institutional</i>		
Assembly Hall/Churches: With kitchen	Seat	45
Assembly Hall/Churches: No kitchen	Seat	23
Fire station without full time employee, floor drains or food	Person	19
Town Hall	Seat	23
<i>Medical/Personal Care</i>		
Hospital: Including laundry	Bed	1,050
Nursing/Special Care Home	Resident	600
Nursing/Special Care Home: Add per employee	Employee	80
Medical Office: Doctors, nurses, medical staff	Person	273
Medical Office: Office staff add	Person	80
Medical Office: Patient add	Person	23
Dental Office	Chair	757
Dental Office – waterless units	Chair	0
Dental Office: Staff/Patient add	Person	80
<i>Schools</i>		
School: Cafeteria, gym and shower	Student	90 Add to base flow for school
School: Cafeteria only	Student	80 Add to base flow for school
School: Gym with showers only	Student	30 Add to base flow for school
School: Elementary – washrooms only	Student	26
School: High – washrooms only	Student	45
School: Junior high – washrooms only	Student	34
School Boarding: Resident student	Student	136
School Boarding: Non-resident staff	Person	80
<i>Food Service</i>		
Bakery: Sanitary only	Employee	68
Bar/Lounge	Seat	140
Bar/Lounge: Add per employee	Employee	80
Restaurant: Not 24 hour	Seat	160
Restaurant: Add per employee	Employee	80
Restaurant: Take Out	Seat	70
Taverns/Bars/Lounges with minimal food service	Seat	140
<i>Commercial</i>		
Office	Employee	80
Beauty Salon	Station	400

**Table B3
Design Wastewater Flows**

Facility	Unit of Measure	Maximum Design Flow (Litres/day)
Beauty Salon: Add for personnel	Person	38
Veterinary Clinic (3 doctors or less): No boarding	Total	2,900
Dog Kennel	Enclosure	73
Laundromat: Self Serve	Machine	1,700
Laundromat: In apartment building	Machine	1,700
Shopping Centre	Space	10
Shopping Centre	Employee	80
<i>Commercial/Automobile</i>		
Automobile Gas Station: Single hose pump	Unit	570 (does not include restaurant)
Car Wash *	Vehicle	189
* requires oil water separators with discharge to a closed storm sewer or an in-ground disposal system.		
<i>Commercial/Hospitality</i>		
Motel	Unit	320
Motel	Housekeeping unit	450
Motel: Dining room	Seat	160
Motel: Bar and lounge	Seat	68
Hotel	Guest	136
Hotel: Add for employees	Employee	36
Boarding House/Dormitory	Resident	180
Senior Citizens Home	Resident	227
Day Care Centers: Staff and children	Person	80
<i>Recreation/Camping</i>		
Campgrounds: Tents only – No service	Site	320
Campgrounds: Trailers - water and electrical – 2 way	Site	320
Campgrounds: Trailers - water, sewer and electrical – 3 way	Site	390
Campgrounds: With central comfort stations	Add for dump station	390
Day Camps: No meal	Person	70
Day Camps: Meals	Person	100
Summer Camps	Camper/Instructor	160
<i>Parks, Beaches and Picnic Grounds</i>		
Picnic and Fairgrounds: With bath houses, showers, toilets	Person	38
Picnic and Fairgrounds: With toilets only	Person	18
Beaches with Showers and Toilets	Person	40
Visitor Centre	Person	18
Visitor Centre: add Employee	Employee	80
<i>Golf/Country Clubs</i>		
Golf/Country Club	Round	18
Golf Clubs and Restaurant add	Seat	35

**Table B3
Design Wastewater Flows**

Facility	Unit of Measure	Maximum Design Flow (Litres/day)
Golf Clubs	Fixture	1,800
Golf/Country Clubs: Showers	Person	40
Golf/Country Clubs: Day staff – Add	Employee	80
<i>Recreation General</i>		
Theatre	Seat	18
Theatre: Drive-in – food	Space	23
<i>Recreation/Sport</i>		
Bowling Alleys: Without bar and restaurant	Alley	105
Bowling Alleys: With bar or restaurant	Alley	800
Ice Rink	Seat	11
Ice Rink: Participant add	Person	38
Stadium	Seat	18
Swimming Pool	Customer	45
Water Slide Park	Visitor	18
Gym: Participant	Person	38
Gym: Spectator	Person	18
Tennis/Racquetball: Excluding food	Court	946
Outdoor Sport Facilities: Toilet only	Person	18

NOTES:***Approximate Flushing Frequencies***

Residential	5 flushes per day
Schools	2 flushes per student per day
Hotel/Motel Room	4-6 flushes per day
Restaurant	0.5 flushes per meal per day
General Commercial	2-4 flushes per employee per 8 hr
Industrial	3 flushes per employee per 8 hr
Ski Areas	1 flush per skier per day
Campgrounds with Facilities	3 flushes per person per night

Note: Flow reduction - Facilities that install low flow or no flow fixtures may have reduction of flow applied. Site assessor or consulting engineers may apply 20% to 50% reduction to the design based on design approach.

APPENDIX C Lot Size Standards and Setbacks

Prior to the development of a parcel of land, the land must be categorized in order to determine the appropriate lot size and lot width for servicing. Lot categorization is detailed in Subsection 23(1) of the *Planning Act* Subdivision Development Regulations and it reads as follows:

23. (1) Lots shall be categorized according to the following standards:

- (a) Category I, where the lot has a depth of permeable natural soil of 2 feet (0.61 metre) or greater, and where the depth to bedrock and the depth to the maximum groundwater elevation is 4 feet (1.22 metres) or greater;
- (b) Category II, where the lot has a depth of permeable natural soil greater than 1 foot (0.3 metre), but less than 2 feet (0.61 metre), and where the depth to the bedrock and the depth to the maximum groundwater elevation is 4 feet (1.2 metre) or greater;
- (c) Category III, where the lot has a depth of permeable natural soil of 1 foot (0.3 metre) or greater, and where either or both of the following conditions exist:
 - (i) the depth to the bedrock is 2 feet (0.61 metre) or greater, but less than 4 feet (1.22 metre),
 - (ii) the depth to the maximum groundwater elevation is 2 feet (0.61 metre) or greater, but less than 4 feet (1.22 metre);
- (d) Category IV, where the lot has a depth of permeable natural soil of less than 1 foot (0.3 metre), and where the depth to the bedrock is greater than 1 foot (0.3 metre) and water table greater than 2 feet (0.61 metre) but less than 4 feet (1.22 metre);
- (e) Category V, where the depth to bedrock is less than 1 foot (0.3 metre), or the depth to water table is less than 2 feet (0.6 m), the lot is not developable.

Table C1 – Minimum Lot Size Standards – Residential Developments

a) Servicing	b) Lot Category	c) Number of Dwelling Units	d) Minimum Lot Area sq.ft. / sq.m.	e) Minimum Circle Diameter to be Contained Within the Boundaries of the Lot feet/metres
On-site water and on-site sewerage system	I	1	25,000 sq.ft. / 2,322.5 sq.m.	150 ft. / 45.7 m
		2	30,000 sq.ft. / 2,787 sq.m.	160 ft. / 48.8 m
		3	35,000 sq.ft. / 3,251.5 sq.m.	175 ft. / 53.5 m
		4	40,000 sq.ft. / 3,717 sq.m.	200 ft. / 61 m
		more than 4	40,000 sq.ft. / 3,717 sq.m., plus 1,500 sq.ft. / 457 sq.m. for each additional unit	200 ft. / 61 m
On-site water and on-site sewerage system	II	1	35,000 sq.ft. / 3,251.5 sq.m.	175 ft. / 53.3 m
		2	40,000 sq.ft. / 3,717 sq.m.	200 ft. / 68.6 m
		3	45,000 sq.ft. / 4,180.5 sq.m.	225 ft. / 68.6 m
		4	50,000 sq.ft. / 4,645 sq.m.	250 ft. / 76.2 m
		more than 4	50,000 sq.ft. / 4,645 sq.m., plus 1,500 sq.ft. / 457 sq.m. for each additional unit	250 ft. / 76.2 m
On-site water and on-site sewerage system	III	1	51,000 sq.ft. / 4,738.5 sq.m.	225 ft. / 68.6 m
		2	56,000 sq.ft. / 5,202 sq.m.	250 ft. / 76.2 m
		3	61,000 sq.ft. / 5,666.5 sq.m.	275 ft. / 83.8 m
		4	66,000 sq.ft. / 6,131 sq.m.	300 ft. / 91.4 m
		more than 4	66,000 sq.ft. / 6,131 sq.m., plus 1,500 sq.ft. / 457 sq.m. for each additional unit	300 ft. / 91.4 m
On-site water supply and on-site sewerage system	IV	1 2 3 4 more than 4	75,000 sq.ft. / 6,975 sq.m. 80,000 sq.ft. / 7,440 sq.m. 85,000 sq.ft. / 7,905 sq.m. 90,000 sq.ft. / 8,370 sq.m. 90,000 sq.ft. / 8,370 sq.m., plus 1,500 sq.ft. / 457 sq.m. for each additional unit	300 ft. / 91.4 m
On-site water supply and on-site sewerage system	V	N/A	Not Developable	N/A
Central water supply and on-site sewerage system	I	1	20,000 sq.ft. / 1,858 sq.m.	125 ft. / 38.1 m
		2	25,000 sq.ft. / 2,322.5 sq.m.	150 ft. / 45.7 m
		3	30,000 sq.ft. / 2,787 sq.m.	160 ft. / 48.8 m
		4	35,000 sq.ft. / 3,251.5 sq.m.	175 ft. / 53.3 m
		more than 4	35,000 sq.ft. / 3,251.5 sq.m., plus 1,500 sq.ft. / 457 sq.m. for each additional unit	175 ft. / 53.3 m
Central water supply and on-site sewerage system	II	1	25,000 sq.ft. / 2,322.5 sq.m.	150 ft. / 45.7 m
		2	30,000 sq.ft. / 2,787 sq.m.	160 ft. / 48.8 m
		3	35,000 sq.ft. / 3,251.5 sq.m.	175 ft. / 53.3 m
		4	40,000 sq.ft. / 3,717 sq.m.	200 ft. / 61 m
		more than 4	40,000 sq.ft. / 3,717 sq.m., plus 1,500 sq.ft. / 457 sq.m. for each additional unit	200 ft. / 61 m
Central water supply and on-site sewerage system	III	1	40,000 sq.ft. / 3,717 sq.m.	200 ft. / 61 m
		2	45,000 sq.ft. / 4,180.5 sq.m.	225 ft. / 68.6 m
		3	50,000 sq.ft. / 4,645 sq.m.	250 ft. / 76.2 m
		4	55,000 sq.ft. / 5,110 sq.m.	275 ft. / 83.8 m
		more than 4	55,000 sq.ft. / 5,110 sq.m., plus 1,500 sq.ft. / 457 sq.m. for each additional unit	275 ft. / 83.8 m
Central water supply and on-site sewerage system	IV	1	60,000 sq.ft. / 5,580 sq.m.	275 ft. / 83.8 m
		2	65,000 sq.ft. / 6,045 sq.m.	
		3	70,000 sq.ft. / 6,510 sq.m.	
		4	75,000 sq.ft. / 6,975 sq.m.	
		more than 4	75,000 sq.ft. / 6,975 sq.m., plus 1,500 sq.ft. / 457 sq.m. for each additional unit	
Central water supply and on-site sewerage system	V	N/A	Not Developable	N/A

Table C2 – Minimum Setback Distances

	Septic Tank (holding tank, pumping and dosing chamber)		Grease Tank		Disposal Field		Sewer Line	
	Metres	Ft.	Metres	Ft.	Metres	Ft.	Metres	Ft.
Water well	15.2	50	15.2	50	15.2	50	3.0	10
Property boundary	3.0	10	3.0	10	3.0	10		--
Beach setback *	22.9	75	22.9	75	22.9	75		--
Building with foundation **	4.6	15	1.5	5	6.1	20		--
Building without foundation	---	---	---	---	4.6	15		--
Water line	3.0	10	3.0	10	3.0	10	0.45	1.5
Natural boundary of a body of water	15.2	50	15.2	50	15.2	50		--

* existing lots prior to 1993 only require 50-foot setback from bank or twice the erosion rate for the area.

** variances may be given for slab on grade or walk out basements in tight situations.

Appendix D Disposal Field Length Selection Tables
Minimum Field Tile Length by Lot Category

Category I												
Distance to Bedrock or Water Table from Ground Surface: Greater than 1.2 m (4 ft)												
Depth of Permeable Soil from Ground Surface: Greater than 0.6 m (2 ft)												
System Description	Minimum Trench Width	Number of Bedrooms								Slope %		
		2		3		4		5		<5	5-30	>30
		Standard	LF	Standard	LF	Standard	LF	Standard	LF			
1. Multiple Trench System	0.6 m (2.0 ft)	85 m (280 ft)	68 m (224 ft)	110 m (360 ft)	88 m (288 ft)	134 m (440 ft)	108 m (352 ft)	162 m (530 ft)	130 m (425 ft)	Y	P	N
2. Alternative Multiple Trench System	0.6 m (2.0 ft)	67 m (220 ft)	54 m (176 ft)	91 m (300 ft)	73 m (240 ft)	116 m (380 ft)	93 m (305 ft)	140 m (460 ft)	112 m (368 ft)	Y	P	N
3. Contour System Type C1	0.9 m (3.0 ft)	30 m (100 ft)	---	37 m (120 ft)	---	49 m (160 ft)	40 m (130 ft)	61 m (200 ft)	49 m (160 ft)	N	Y	EDS
4. Contour System Type C2	0.9 m (3.0 ft)	30 m (100 ft)	---	37 m (120 ft)	---	49 m (160 ft)	40 m (130 ft)	61 m (200 ft)	49 m (160 ft)	N	Y	EDS
5. Chamber system Multiple Trench	0.9 m (3.0 ft)	43 m (138 ft)	---	55 m (175 ft)	---	69 m (225 ft)	---	80 m (262 ft)	---	Y	P	EDS
6. EZ flow System ¹ Multiple Trench	0.6 m (2.0 ft)	57 m (187 ft)	---	74 m (243 ft)	---	90 m (296 ft)	---	108 m (355 ft)	---	N	N	EDS

Category II												
Distance to Bedrock or Water Table from Ground Surface: Greater than 1.2 m (4 ft)												
Depth of Permeable Soil from Ground Surface: 0.3 to 0.6 m (1 to 2 ft)												
System Description	Minimum Trench Width	Number of Bedrooms								Slope %		
		2		3		4		5		<5	5-30	>30
		Standard	LF	Standard	LF	Standard	LF	Standard	LF			
1. Multiple Trench System	0.6 m (2.0 ft)	110 m (360 ft)	88 m (288 ft)	134 m (440 ft)	108 m (352 ft)	162 m (530 ft)	130 m (425 ft)	180 m (590 ft)	144 m (473 ft)	Y	P	EDS
2. Alternative Multiple Trench System	0.6 m (2.0 ft)	85 m (280 ft)	68 m (224 ft)	110 m (360 ft)	88 m (288 ft)	134 m (440 ft)	108 m (352 ft)	162 m (530 ft)	130 m (425 ft)	Y	P	N
3. Contour System Type C2 and Type C3	0.9 m (3.0 ft)	37 m (120 ft)	---	46 m (150 ft)	37 m (120 ft)	57 m (187 ft)	46 m (150 ft)	71 m (235 ft)	57 m (187 ft)	N	Y	EDS
4. Chamber System Multiple Trench	0.9 m (3.0 ft)	53 m (175 ft)	---	69 m (225 ft)	---	86 m (280 ft)	---	100 m (328 ft)	---	Y	P	EDS
5. EZ flow System ¹ Multiple Trench	0.6 m (2.0 ft)	74 m (243 ft)	---	90 m (296 ft)	---	108 m (355 ft)	---	120 m (395 ft)	---	N	N	EDS

Category III												
Distance to Bedrock from Ground Surface: 0.6 to 1.2 m (2 to 4 ft)												
Depth of Permeable Soil from Ground Surface: 0.6 to 1.2 m (2 to 4 ft)												
System Description	Minimum Trench Width	Number of Bedrooms								Slope %		
		2		3		4		5		<5	5-30	>30
		Standard	LF	Standard	LF	Standard	LF	Standard	LF			
1. Multiple Trench System	0.6 m (2.0 ft)	85 m (280 ft)	68 m (224 ft)	110 m (360 ft)	88 m (288 ft)	134 m (440 ft)	108 m (352 ft)	162 m (530 ft)	130 m (425 ft)	Y	P	N
2. Alternative Multiple Trench System	0.6 m (2.0 ft)	67 m (220 ft)	54 m (176 ft)	91 m (300 ft)	73 m (240 ft)	116 m (380 ft)	93 m (305 ft)	140 m (460 ft)	112 m (368 ft)	Y	P	N
3. Contour System Type C1 and Type C3	0.9 m (3.0 ft)	30 m (100 ft)	---	37 m (120 ft)	---	49 m (160 ft)	40 m (130 ft)	61 m (200 ft)	49 m (160 ft)	N	P	EDS
4. Contour System Type C2	0.9 m (3.0 ft)	30 m (100 ft)	---	37 m (120 ft)	---	49 m (160 ft)	40 m (130 ft)	61 m (200 ft)	49 m (160 ft)	N	Y	EDS
5. Chamber System Multiple Trench	0.9 m (3.0 ft)	43 m (138 ft)	---	55 m (175 ft)	---	69 m (225 ft)	---	80 m (262 ft)	---	Y	P	N
6. EZ flow System ¹ Multiple Trench	0.6 m (2.0 ft)	57 m (187 ft)	---	74 m (243 ft)	---	90 m (296 ft)	---	108 m (355 ft)	---	N	N	EDS

Category III												
Distance to Bedrock from Ground Surface: 0.6 to 1.2 m (2 to 4 ft.)												
Depth of Permeable Soil from Ground Surface: 0.3 to 0.6 m (1 to 2 ft)												
System Description	Minimum Trench Width	Number of Bedrooms								Slope %		
		2		3		4		5		<5	5-30	>30
		Standard	LF	Standard	LF	Standard	LF	Standard	LF			
1. Multiple Trench System	0.6 m (2.0 ft.)	110 m (360 ft)	88 m (288 ft)	134 m (440 ft)	108 m (352 ft)	162 m (530 ft)	130 m (425 ft)	180 m (590 ft)	144 m (473 ft)	Y	P	N
2. Alternative Multiple Trench System	0.6 m (2.0 ft)	85 m (280 ft)	68 m (224 ft)	110 m (360 ft)	88 m (288 ft)	134 m (440 ft)	108 m (352 ft)	162 m (530 ft)	130 m (425 ft)	Y	P	N
3. Contour System Type C1	0.9 m (3.0 ft)	37 m (120 ft)	—	46 m (150 ft)	37 m (120 ft)	57 m (187 ft)	46 m (150 ft)	71 m (235 ft)	57 m (187 ft)	N	P	EDS
4. Contour System Type C2 and Type C3	0.9 m (3.0 ft)	37 m (120 ft)	—	46 m (150 ft)	37 m (120 ft)	57 m (187 ft)	46 m (150 ft)	71 m (235 ft)	57 m (187 ft)	N	Y	EDS
5. Chamber System Multiple Trench	0.9 m (3.0 ft)	53 m (175 ft)	—	69 m (225 ft)	—	86 m (280 ft)	—	100 m (328 ft)	—	Y	P	EDS
6. EZ _{flow} System ¹ Multiple Trench	0.6 m (2.0 ft)	74 m (243 ft)	—	90 m (296 ft)	—	108 m (355 ft)	—	120 m (395 ft)	—	N	N	EDS

Category III												
Water Table 0.6 to 1.2 m (2 to 4 ft)												
System Description	Minimum Trench Width	Number of Bedrooms								Slope %		
		2		3		4		5		<5	5-30	>30
		Standard	LF	Standard	LF	Standard	LF	Standard	LF			
All systems to be designed by a Professional Engineer	EDS	EDS		EDS		EDS		EDS		EDS	EDS	EDS

Category IV												
Distance to Bedrock from Ground Surface is greater than 0.3 m (1 ft.)												
Depth of Permeable Soil from Ground Surface: 0.0 to 0.3 m (0 to 1 ft)												
Note: Where the distance to Water Table from Ground Surface is less than 1.2 m (4 ft.) the system is to be designed by a Professional Engineer												
System Description	Minimum Trench Width	Number of Bedrooms								Slope %		
		2		3		4		5		<5	5-30	>30
		Standard	LF	Standard	LF	Standard	LF	Standard	LF			
1. Multiple Trench System	0.6 m (2.0 ft.)	110 m (360 ft)	88 m (288 ft)	134 m (440 ft)	108 m (352 ft)	162 m (530 ft)	130 m (425 ft)	180 m (590 ft)	144 m (473 ft)	Y	P	N
2. Alternative Multiple Trench System	0.6 m (2.0 ft)	85 m (280 ft)	68 m (224 ft)	110 m (360 ft)	88 m (288 ft)	134 m (440 ft)	108 m (352 ft)	162 m (530 ft)	130 m (425 ft)	Y	P	N
4. Contour System Type C1 and Type C2	N/A	N/A	N/A	N/A	N/A	N/A	N/A	N/A	N/A	N	N	N
4. Contour System Type C3	0.9 m (3.0 ft)	37 m (120 ft)	—	46 m (150 ft)	37 m (120 ft)	57 m (187 ft)	46 m (150 ft)	71 m (235 ft)	57 m (187 ft)	N	Y	EDS
5. Chamber System Multiple Trench	0.9 m (3.0 ft)	53 m (175 ft)	—	69 m (225 ft)	—	86 m (280 ft)	—	100 m (328 ft)	—	Y	P	EDS
6. EZ _{flow} System ¹ Multiple Trench	0.6 m (2.0 ft)	74 m (243 ft)	—	90 m (296 ft)	—	108 m (355 ft)	—	120 m (395 ft)	—	N	N	EDS

Category V												
Distance to Bedrock from Ground Surface is less than 0.3 m (1 ft.)												
Distance to water table is less than 0.6 m (2 ft.)												
System Description	Minimum Trench Width	Number of Bedrooms								Slope %		
		2		3		4		5		<5	5-30	>30
		Standard	LF	Standard	LF	Standard	LF	Standard	LF			
Development of sewage disposal systems is not permitted in this Category	N/A	N/A	N/A	N/A	N/A	N/A	N/A	N/A	N/A	N/A	N/A	N/A

- LF 20% reduction for low flow fixtures (6l. toilets)
EDS Engineered Designed System
Y "Yes" - System type permitted
P "Possible" - System is permitted depending on slope
N "No" - System type not permitted
N/A Not Applicable
¹ An allowance of a 1/3 reduction from a standard multiple trench system is permitted for the EZ_{flow} system. This is for a double line format with the second line being the aggregate line only (no pipe).
² Systems in this category will require the addition of Good Quality Fill.
³ Systems in this category will require the addition of a minimum of 1.2 meters (4 feet) of Good Quality Fill.

- Notes:
- Systems up to 5 bedrooms (2,270 L/day) can be selected by a Licensed Contractor and a Site Assessor from the above table.
 - Systems greater than 5 bedroom and up to 6810 L/day (1500 Igal/day) can be determined by using Design Flow table, Schedule B and the above table in Schedule D.
 - Systems greater than 6810 L/day (1500 Igal/day) shall be designed by a Professional Engineer Licensed to practice in Prince Edward Island.
 - For septic tank sizing refer to Table 1.1 Minimum capacity of Septic Tanks for Dwellings.

EXPLANATORY NOTES

SECTION 1 provides definitions of terms used in these regulations and the Standards set out in the Schedule to these regulations.

SECTION 2 clarifies that a Category I, II, III, IV or V lot is a lot that has been assessed as such in accordance with the Subdivision and Development regulations under the *Planning Act*.

SECTION 3 provides that these regulations and the standards apply to the installation, construction, reconstruction or modification of sewage disposal systems, and that when an existing sewage disposal system is to be expanded or modified the Minister, to protect public health or the environment, may by order require that the whole system or any part of it be modified or replaced in accordance with these regulations and the Standards.

SECTION 4 establishes the licensing criteria that apply to the issuance and renewal of a septic contractor's license, including the initial and ongoing educational requirements that must be met by an applicant, the

duration of the license, the professional responsibilities of the license holder and the actions that may result in suspension of the license.

SECTION 5 establishes the licensing criteria that apply to the issuance and renewal of a site assessor's license, including the required education or equivalent experience of the applicant, the duration of the license and the actions that may result in suspension of the license.

SECTION 6 establishes the criteria that apply to the registration of a registered installer, including initial and ongoing educational requirements, the duration of the registration and the action that will result in cancellation of the registration.

SECTION 7 establishes the criteria that apply to the issuance of a sewage disposal system installation permit to a licensed septic contractor. It also prohibits the installation, construction, reconstruction or modification of a sewage disposal system except in accordance with these regulations and the Standards, and any conditions set out in the permit. The section further authorizes the Minister to prohibit the installation, construction, reconstruction or modification of a sewage disposal system when weather conditions or ground conditions are, in the Minister's opinion, unsuitable. The section also requires a professional engineer or licensed septic contractor to provide 24 hours' notice to the Minister before commencing the installation of a sewage disposal system.

SECTION 8 prohibits the covering of a sewage disposal system without first notifying the Minister and receiving instructions from the Minister, and authorizes the Minister to order the owner or the licensed septic contractor of a sewage disposal system that has been covered without permission to uncover all or part of the system for inspection.

SECTION 9 establishes the fees that apply to the issuance or renewal of licenses, registrations and permits and the registration of registered documents, and the fee for additional inspections or re-inspections of sewage disposal systems.

SECTION 10 requires a licensed septic contractor to furnish a certificate of compliance to the owner and the Minister within 60 days of construction, reconstruction, installation or modification of a sewage disposal system.

SECTION 11 authorizes the Minister to require an owner of a lot to which an application for a sewage disposal system installation permit applies to have a site suitability assessment completed on the lot, and requires the site suitability assessment to assess the lot based on the categories established under section 23 of the Subdivision and Development Regulations under the *Planning Act* R.S.P.E.I. 1988, Cap. P-8.

SECTION 12 prohibits a person, other than a professional engineer or an environment officer, from performing a site suitability assessment unless the person holds a site assessor's license.

SECTION 13 authorizes the Minister to vary the requirements of these regulations and the Standards respecting design and location of a sewage disposal system where compliance is not possible, except that the variance with respect to the setback from a well shall not be reduced by more than 10 percent of the required distance.

SECTION 14 prohibits the cleaning of a sewage disposal system or wastewater treatment system and the spreading of sludge except by a person who holds a pumper's license and in accordance with these regulations. It also establishes the application process for a pumper's license and the criteria for the disposal of sludge, and prohibits the placing of sludge in a holding site without the prior approval of the Minister. Finally, it authorizes the Minister to approve an alternative disposal method or site for sludge disposal if the Minister is satisfied that the method or site is appropriate for the purpose.

SECTION 15 prohibits the disposal of unstabilized sewage or septage, or septage temporarily held at a septage holding facility, at any place other than a waste treatment system approved by the Minister.

SECTION 16 provides that it is an offence to contravene a provision of these regulations or the Standards or to fail to comply with a condition of a permit or other obligation imposed by the regulations, the Standards or an order of the Minister. The penalty for contravention is set out in section 32 of the Act.

SECTION 17 provides that the Standards set out in the Schedule to these regulations are adopted and form part of these regulations. The section also clarifies that unless a provision of the Standards specifies otherwise, it is the licensed septic contractor who is responsible for ensuring that the requirements of the Standards are met in respect of a sewage disposal system installed, constructed, reconstructed or modified by the licensed septic contractor.

SECTION 18 provides that a license, permit or registration that was valid and in force on the coming into force of these regulations continues in force according to its terms until it expires or is suspended under these regulations.

SECTION 19 provides for the revocation of the *Environmental Protection Act* Sewage Disposal Regulations (EC403/03).

SECTION 20 provides for the commencement of these regulations.

EC2013-626

FINANCIAL ADMINISTRATION ACT CERTAIN ACCOUNTS RECEIVABLE UNDER THE ENVIRONMENT TAX ACT AUTHORITY TO WRITE-OFF

Pursuant to subsection 26.1(1) of the *Financial Administration Act* R.S.P.E.I. 1988, Cap. F-9 Council authorized the write-off of certain accounts receivable under the *Environment Tax Act* totalling \$956.12 (including interest to September 30, 2013) as follows:

SCHEDULE (ENVIRONMENT TAX ACT, WRITE-OFFS)

ACCOUNT OF	AMOUNT WRITTEN-OFF
O'Halloran, Joseph J. carrying on business under the style name Joe's Quality Auto Service O'Leary	\$421.85
101233 P.E.I. Inc. carrying on business under the style name Midnight Mechanical O'Leary	<u>534.27</u>
Total	<u>\$956.12</u>

EC2013-627

**FINANCIAL ADMINISTRATION ACT
CERTAIN ACCOUNTS RECEIVABLE
UNDER THE
REVENUE TAX ACT
AUTHORITY TO WRITE-OFF**

Pursuant to subsection 26.1(1) of the *Financial Administration Act* R.S.P.E.I. 1988, Cap. F-9 Council authorized the write-off of certain accounts receivable under the *Revenue Tax Act* totalling \$258,321.93 (including interest to September 30, 2013) as follows:

**SCHEDULE
(REVENUE TAX ACT, WRITE-OFFS)**

ACCOUNT OF	AMOUNT WRITTEN-OFF
100385 P.E.I. Inc. carrying on business under the style name Pizza Shack Tignish	\$25,216.36
100456 PEI Inc. carrying on business under the style name Northport Pier Inn Alberton	\$229.17
100870 P.E.I. Inc. Fortune Cove	\$207.04
Above and Beyond Medical Aesthetics Inc. Bloomfield	\$10,354.27
Alizadeh, Josiah Kensington	\$2,379.66
CTY Enterprises Inc. Central Bedeque	\$16,942.50
Davey, Paul Charlottetown	\$2,901.18
East Coast Maintenance Inc. Cornwall	\$18,760.54
Epping, Sara Jane carrying on business under the style name One Stop Crop Kensington	\$3,096.77
Ford, Cory carrying on business under the style name Custom Collision Mount Pleasant	\$7,101.56
Kadey, Kevin carrying on business under the style name Island Accounting Services Tyne Valley	\$952.89
Little Mac Shoppe Inc. Charlottetown	\$38,587.42
MacAdam, Jonathan Cory carrying on business under the style name Family Fashions Pownal	\$870.87
MacLeod, Craig carrying on business under the style name Seal Cove Waterfront Dream Cottage Montague	\$3,438.92

MacLeod, George carrying on business under the style name Eastern Sandblasting & Painting Montague	\$4,611.44
Mueller, Katharina carrying on business under the style name Simple Solutions Wedding & Event Planning Summerside	\$1,297.71
Nuesch, Sabine carrying on business under the style name Victoria's Glass Studio/Nature's Creation Victoria	\$18,843.10
O'Halloran, Joseph J. carrying on business under the style name Joe's Quality Auto Service O'Leary	\$9,591.81
Pederson, Les carrying on business under the style name NCS Technology Solutions Cornwall	\$21,609.00
Schellekens, John carrying on business under the style name JC Auto Service Montague	\$15,775.99
Seatreat Restaurant (2008) Ltd. Charlottetown	\$31,773.28
Smith, Tracy Bonshaw	\$20,812.43
Telepath Corporation Ottawa, Ontario	\$1,347.26
The Pines Bed & Breakfast Inc. carrying on business under the style name The Pines Bicycle Rentals Montague	\$1,620.76
Total	<u>\$258,321.93</u>

EC2013-628

PRINCE EDWARD ISLAND
LANDS PROTECTION ACT
PETITION TO ACQUIRE A LAND HOLDING
WARREN MIRON AND MEAGHAN MIRON
(APPROVAL)

Pursuant to section 4 and section 9 of the *Prince Edward Island Lands Protection Act* R.S.P.E.I. 1988, Cap. L-5 Council granted permission to Warren Miron and Meaghan Miron, both of Kanata, Ontario to acquire a land holding of approximately four decimal three four (4.34) acres of land in Lot 41, Kings County, Province of Prince Edward Island, being acquired from Atlantic Shellfish Products Inc. of Morell, Prince Edward Island PROVIDED THAT the said real property is identified for non-development use pursuant to the Land Identification Regulations (EC606/95) made under the said Act.

EC2013-629

PRINCE EDWARD ISLAND
LANDS PROTECTION ACT
PETITION TO ACQUIRE A LAND HOLDING
STEPHEN PLUMMER AND WENDY PLUMMER
(APPROVAL)

Pursuant to section 4 and section 9 of the *Prince Edward Island Lands Protection Act* R.S.P.E.I. 1988, Cap. L-5 Council granted permission to Stephen Plummer and Wendy Plummer, both of Hagensborg, British Columbia to acquire a land holding of approximately seventeen (17) acres of land in Lot 1, Prince County, Province of Prince Edward Island, being acquired from Wilfred Alich and Sandra Alich Storr, both of Tignish, Prince Edward Island PROVIDED THAT the said real property is identified for non-development use pursuant to the Land Identification Regulations (EC606/95) made under the said Act.

EC2013-630

PRINCE EDWARD ISLAND
LANDS PROTECTION ACT
PETITION TO ACQUIRE A LAND HOLDING
MICHAEL SACKRIDER AND JOANNA SACKRIDER
(APPROVAL)

Pursuant to section 4 and section 9 of the *Prince Edward Island Lands Protection Act* R.S.P.E.I. 1988, Cap. L-5 Council granted permission to Michael Sackrider and Joanna Sackrider, both of Stanchel, Prince Edward Island to acquire a land holding of approximately fifty-two decimal nine three (52.93) acres of land in Lot 67, Queens County, Province of Prince Edward Island, being acquired from Alistair Aiken and Marlene Aiken, both of Stanchel, Prince Edward Island PROVIDED THAT the said real property is identified for non-development use pursuant to the Land Identification Regulations (EC606/95) made under the said Act.

EC2013-631

PRINCE EDWARD ISLAND
LANDS PROTECTION ACT
PETITION TO ACQUIRE A LAND HOLDING
MICHAEL SACKRIDER AND JOANNA SACKRIDER
(APPROVAL)

Pursuant to section 4 and section 9 of the *Prince Edward Island Lands Protection Act* R.S.P.E.I. 1988, Cap. L-5 Council granted permission to Michael Sackrider and Joanna Sackrider, both of Stanchel, Prince Edward Island to acquire a land holding of approximately two hundred and ninety-six decimal two two (296.22) acres of land in Lot 67, Queens County, Province of Prince Edward Island, being acquired from Alistair Aiken of Stanchel, Prince Edward Island PROVIDED THAT the said real property is identified for non-development use pursuant to the Land Identification Regulations (EC606/95) made under the said Act.

EC2013-632

PRINCE EDWARD ISLAND
LANDS PROTECTION ACT
PETITION TO ACQUIRE A LAND HOLDING
COULSON REALTY LTD.
(APPROVAL)

Pursuant to section 5 of the *Prince Edward Island Lands Protection Act* R.S.P.E.I. 1988, Cap. L-5 Council granted permission to Coulson Realty Ltd. of Kensington, Prince Edward Island to acquire an interest in a land holding of approximately forty-four decimal five two (44.52) acres of land in Lot 18, Prince County, Province of Prince Edward Island, being acquired from Thomas Coulson of Kelvin Grove, Prince Edward Island.

EC2013-633

PRINCE EDWARD ISLAND
LANDS PROTECTION ACT
PETITION TO ACQUIRE A LAND HOLDING
GLADSTONE HOLDINGS INC.
(APPROVAL)

Pursuant to section 5 of the *Prince Edward Island Lands Protection Act* R.S.P.E.I. 1988, Cap. L-5 Council granted permission to Gladstone Holdings Inc. of Murray River, Prince Edward Island to acquire a land holding of approximately forty (40) acres of land in Lot 64, Kings County, Province of Prince Edward Island, being acquired from Son-Hai Minh Huynh (a.k.a. Son-Hgi Huynh), Minh Le (a.k.a. Minh Thi Le), Hanna B. Le (a.k.a. Hanna Le), Lee Thanh Son Le (a.k.a. Lee T.S. Le), Vanessa Le, Nga Bich Thi Le (a.k.a. Nga Bich Le) and Tuan Tran Pham, all of Calgary, Alberta.

Further, Council noted that part of the said land holding, being Provincial Property No. 298505, was previously identified for non-development use in accordance with section 2 of the Land Identification Regulations (EC606/95) made under the said Act. Identification continues to apply.

EC2013-634

PRINCE EDWARD ISLAND
LANDS PROTECTION ACT
PETITION TO ACQUIRE A LAND HOLDING
HOLDINGS 0517 INC.
(APPROVAL)

Pursuant to section 5 of the *Prince Edward Island Lands Protection Act* R.S.P.E.I. 1988, Cap. L-5 Council granted permission to Holdings 0517 Inc. of Charlottetown, Prince Edward Island to acquire a land holding of approximately one (1) acre of land in Lot 21, Queens County, Province of Prince Edward Island, being acquired from Dorothy Breeze and Leigh MacKay, both of Stanley Bridge, Prince Edward Island.

EC2013-635

PRINCE EDWARD ISLAND
LANDS PROTECTION ACT
PETITION TO ACQUIRE A LAND HOLDING
ISLAND NATURE TRUST
(APPROVAL)

Pursuant to section 5 and section 9 of the *Prince Edward Island Lands Protection Act* R.S.P.E.I. 1988, Cap. L-5 Council granted permission to Island Nature Trust of Charlottetown, Prince Edward Island to acquire a land holding of approximately eighteen decimal five (18.5) acres of land in Lot 58, Queens County, Province of Prince Edward Island, being acquired from Emily Frances Carrington of Thunder Bay, Ontario PROVIDED THAT the said real property is identified for non-development use pursuant to the Land Identification Regulations (EC606/95) made under the said Act.

EC2013-636

PRINCE EDWARD ISLAND
LANDS PROTECTION ACT
PETITION TO ACQUIRE A LAND HOLDING
MW HOLDINGS LTD.
(APPROVAL)

Pursuant to section 5 and section 9 of the *Prince Edward Island Lands Protection Act* R.S.P.E.I. 1988, Cap. L-5 Council granted permission to MW Holdings Ltd. of McNeills Mills, Prince Edward Island to acquire a land holding of approximately six (6) acres of land in Lot 12, Prince County, Province of Prince Edward Island, being acquired from Michael G. Wilson of Springhill, Prince Edward Island PROVIDED THAT the said real property is identified for non-development use pursuant to the Land Identification Regulations (EC606/95) made under the said Act.

EC2013-637

PRINCE EDWARD ISLAND
LANDS PROTECTION ACT
PETITION TO ACQUIRE A LAND HOLDING
N.J. CONSTRUCTION
(APPROVAL)

Pursuant to section 5 of the *Prince Edward Island Lands Protection Act* R.S.P.E.I. 1988, Cap. L-5 Council granted permission to N.J. Construction of Charlottetown, Prince Edward Island to acquire a land holding of approximately thirty-nine (39) acres of land in Lot 48, Queens County, Province of Prince Edward Island, being acquired from Roger Balderston of Stratford, Prince Edward Island.

EC2013-638

PRINCE EDWARD ISLAND
 LANDS PROTECTION ACT
 PETITION TO ACQUIRE A LAND HOLDING
 RUSSELL CHING LIMITED
 (APPROVAL)

Pursuant to section 5 and section 9 of the *Prince Edward Island Lands Protection Act* R.S.P.E.I. 1988, Cap. L-5 Council granted permission to Russell Ching Limited of Souris, Prince Edward Island to acquire a land holding of approximately ninety-nine (99) acres of land in Lot 45, Kings County, Province of Prince Edward Island, being acquired from John F. Nolan of Chepstow, Prince Edward Island PROVIDED THAT the said real property is identified for non-development use pursuant to the Land Identification Regulations (EC606/95) made under the said Act.

EC2013-639

PRINCE EDWARD ISLAND
 LANDS PROTECTION ACT
 PETITION TO ACQUIRE A LAND HOLDING
 STEWART ENTERPRISES LIMITED
 (APPROVAL)

Pursuant to section 5 and section 9 of the *Prince Edward Island Lands Protection Act* R.S.P.E.I. 1988, Cap. L-5 Council granted permission to Stewart Enterprises Limited of West Point, Prince Edward Island to acquire a land holding of approximately forty-five decimal eight six (45.86) acres of land in Lot 8, Prince County, Province of Prince Edward Island, being acquired from Curran & Briggs Ltd. of Summerside, Prince Edward Island SUBJECT TO the condition that the said real property not be subdivided. The condition preventing subdivision shall be binding on the said Stewart Enterprises Limited and on all successors in title.

EC2013-640

PRINCE EDWARD ISLAND
 LANDS PROTECTION ACT
 PETITION TO ACQUIRE A LAND HOLDING
 TAYLOR BUILT HOLDINGS INC.
 (TO RESCIND)

Council, having under consideration Orders-in-Council EC2013-521 and EC2013-522 dated July 9, 2013, rescinded the said Orders forthwith, thus rescinding permission for Taylor Built Holdings Inc. of Covehead Road, Prince Edward Island to acquire a land holdings of approximately zero decimal three two (0.32) acres and approximately one decimal four three (1.43) acres of land at Charlottetown, Queens County, Province of Prince Edward Island, from L & A MacEachern Holdings Ltd. of Stratford, Prince Edward Island.

EC2013-641

MENTAL HEALTH ACT
MENTAL HEALTH REVIEW BOARD
APPOINTMENTS

Pursuant to section 27 of the *Mental Health Act* R.S.P.E.I. 1988, Cap. M-6.1 Council made the following appointments:

NAME	TERM OF APPOINTMENT
-------------	----------------------------

as chairperson, via clause 27(3)(a)

Jeffrey Leard	31 August 2013
Summerside	to
(vice Michael Drake, term expired)	31 August 2016

as alternate chairperson, via subsection 27(4)

Michael Ramsay	3 September 2013
Charlottetown	to
(vice Jeffrey Leard, term expired)	31 August 2016

as alternate lay member, via subsection 27(4)

Don MacRae	3 September 2013
Charlottetown	to
(vice Emmett Bradley, term expired)	31 August 2016

EC2013-642

NARCOTICS SAFETY AND AWARENESS ACT
DECLARATION RE

Under authority of section 19 of the *Narcotics Safety and Awareness Act* Stats. P.E.I. 2013, c. 43 Council ordered that a Proclamation do issue proclaiming the said "*Narcotics Safety and Awareness Act*" to come into force effective September 14, 2013.

EC2013-643

NARCOTICS SAFETY AND AWARENESS ACT
MONITORED DRUG REGULATIONS

Pursuant to section 18 of the *Narcotics Safety and Awareness Act* R.S.P.E.I. 1988, Cap. N-.01, Council made the following regulations:

1. In these regulations, "Act" means the *Narcotics Safety and Awareness Act* R.S.P.E.I. 1988, Cap. N-.01. Definition

2. In addition to the controlled substances listed in the Schedules to the *Controlled Drugs and Substances Act* (Canada), a drug product that contains any of the following substances is a monitored drug for the purposes of the Act: Monitored drug
 - (a) Tramadol;
 - (b) Tapentadol;
 - (c) any opioid not listed in Schedule I of the *Controlled Drugs and Substances Act* (Canada).

3. These regulations come into force on September 14, 2013. Commencement

EXPLANATORY NOTES

SECTION 1 defines “Act” for the purposes of the regulations.

SECTION 2 establishes the monitored drugs for the purposes of the Act as all of the controlled substances listed in the Schedules to the *Controlled Drugs and Substances Act* (Canada) and, in addition, any drug product that contains Tramadol, Tapentadol, or an opioid not listed in Schedule I to the *Controlled Drugs and Substances Act* (Canada).

SECTION 3 provides for the commencement of these regulations.

EC2013-644**PUBLIC DEPARTMENTS ACT
ACTING MINISTER
APPOINTMENT**

Under authority of subsection 4(2) of the *Public Departments Act*, R.S.P.E.I. 1988, Cap. P-29 the following appointment was made:

Honourable Wes Sheridan to be Acting Minister of Environment, Labour and Justice and Acting Attorney General commencing on the 10th day of September 2013, and continuing for the duration of the absence from the Province of Honourable Janice Sherry.